

SIEMENS

SIMATIC

S7-300 CPU 31xC and CPU 31x: Technical specifications

Manual

Preface

Guide to the S7-300
documentation 1

Operator controls and
indicators 2

Communication 3

PROFINET 4

Memory concept 5

Cycle and response times 6

General technical
specifications 7

Technical specifications of
CPU 31xC 8

Technical specifications of
CPU 31x 9

ماکان کنترول

This manual is part of the documentation package
with the order number: 6ES7398-8FA10-8BA0

03/2011

A5E00105475-12

Legal information

Warning notice system

This manual contains notices you have to observe in order to ensure your personal safety, as well as to prevent damage to property. The notices referring to your personal safety are highlighted in the manual by a safety alert symbol, notices referring only to property damage have no safety alert symbol. These notices shown below are graded according to the degree of danger.

⚠ DANGER
indicates that death or severe personal injury will result if proper precautions are not taken.
⚠ WARNING
indicates that death or severe personal injury may result if proper precautions are not taken.
⚠ CAUTION
with a safety alert symbol, indicates that minor personal injury can result if proper precautions are not taken.
CAUTION
without a safety alert symbol, indicates that property damage can result if proper precautions are not taken.
NOTICE
indicates that an unintended result or situation can occur if the corresponding information is not taken into account.

If more than one degree of danger is present, the warning notice representing the highest degree of danger will be used. A notice warning of injury to persons with a safety alert symbol may also include a warning relating to property damage.

Qualified Personnel

The product/system described in this documentation may be operated only by **personnel qualified** for the specific task in accordance with the relevant documentation for the specific task, in particular its warning notices and safety instructions. Qualified personnel are those who, based on their training and experience, are capable of identifying risks and avoiding potential hazards when working with these products/systems.

Proper use of Siemens products

Note the following:

⚠ WARNING
Siemens products may only be used for the applications described in the catalog and in the relevant technical documentation. If products and components from other manufacturers are used, these must be recommended or approved by Siemens. Proper transport, storage, installation, assembly, commissioning, operation and maintenance are required to ensure that the products operate safely and without any problems. The permissible ambient conditions must be adhered to. The information in the relevant documentation must be observed.

Trademarks

All names identified by ® are registered trademarks of the Siemens AG. The remaining trademarks in this publication may be trademarks whose use by third parties for their own purposes could violate the rights of the owner.

Disclaimer of Liability

We have reviewed the contents of this publication to ensure consistency with the hardware and software described. Since variance cannot be precluded entirely, we cannot guarantee full consistency. However, the information in this publication is reviewed regularly and any necessary corrections are included in subsequent editions.

Preface

Purpose of this manual

This manual contains essential information about the following:

- Installation
- Communication
- Memory concept
- Cycle and response times
- Technical specifications of the CPUs.

Basic knowledge required

- In order to understand this manual, you require a general knowledge of automation engineering.
- You require knowledge of STEP 7 basic software.

Scope

The name CPU 31xC summarizes all compact CPUs, as table below shows:

CPU	Convention: CPU designations:	Order number	As of firmware version
CPU 312C	CPU 31xC	6ES7312-5BF04-0AB0	V3.3
CPU 313C		6ES7313-5BG04-0AB0	V3.3
CPU 313C-2 PtP		6ES7313-6BG04-0AB0	V3.3
CPU 313C-2 DP		6ES7313-6CG04-0AB0	V3.3
CPU 314C-2 PtP		6ES7314-6BH04-0AB0	V3.3
CPU 314C-2 DP		6ES7314-6CH04-0AB0	V3.3
CPU 314C-2 PN/DP		6ES7314-6EH04-0AB0	V3.3

The name CPU 31x summarizes all standard CPUs, as table below shows:

CPU	Convention: CPU designations:	Order number	As of firmware version
CPU 312	CPU 31x	6ES7312-1AE14-0AB0	V3.3
CPU 314		6ES7314-1AG14-0AB0	V3.3
CPU 315-2 DP		6ES7315-2AH14-0AB0	V3.3
CPU 315-2 PN/DP		6ES7315-2EH14-0AB0	V3.2
CPU 317-2 DP		6ES7317-2AK14-0AB0	V3.3
CPU 317-2 PN/DP		6ES7317-2EK14-0AB0	V3.2
CPU 319-3 PN/DP		6ES7318-3EL01-0AB0	V3.2

All CPUs with PROFINET properties are grouped under the designation CPU 31x PN/DP, as the following table shows:

CPU	Convention: CPU designations:	Order number	As of firmware version
CPU 314C-2 PN/DP	CPU 31x PN/DP	6ES7314-6EH04-0AB0	V3.3
CPU 315-2 PN/DP		6ES7315-2EH14-0AB0	V3.2
CPU 317-2 PN/DP		6ES7317-2EK14-0AB0	V3.2
CPU 319-3 PN/DP		6ES7318-3EL01-0AB0	V3.2

Note

A description of the special features of the failsafe CPUs of the S7 product range is available in the product information at the following Internet address (<http://support.automation.siemens.com/WW/view/en/11669702/133300>).

Note

We reserve the right to include a product Information containing the latest information on new modules or modules of a more recent version.

Changes in comparison to the previous version

The following table contains changes from the previous versions of the following documentation from the S7-300 documentation package:

- Technical specifications manual, version 06/2010
- Operating instructions for installation, version 06/2010

The CPU- 314C-2 PN/DP has been added in delivery stage V3.3. It has the same functionalities as the CPU 314C-2 DP and also has PROFINET functionalities such as those of the CPU 315-2 PN/DP.

In delivery stage V3.3, the functionality and performance of all C-CPU and the CPU 317-2 DP were improved compared to their predecessor versions.

Additional information was taken from the chapter "Information on converting to a CPU 31xC or CPU 31x". If you required more information, however, please refer to the FAQs on the Internet.

CPU	312	312C	313C	313C-2 DP	313C-2 PtP	314	314C-2 DP	314C-2 PtP	315-2 DP	317-2 DP
Encryption of blocks using S7-Block Privacy	X	X	X	X	X	X	X	X	X	X
Integration of a maintenance LED	X ^{1,2}	X ²	X ²	X ²	X ²	X ^{1,2}	X ²	X ²	X ^{1,2}	X ²
Configurable increase of control and monitoring performance	-	-	-	-	-	-	-	-	X	X
Improved operational limits for PT100 Analog input	-	-	X	-	-	-	X	X	-	-
Data set routing	-	-	-	X	-	-	X	-	X ¹	X
Configurable process image	X ¹	X	X	X	X	X ¹	X	X	X ¹	X
Expansion of the block number range	X ¹	X	X	X	X	X ¹	X	X	X ¹	X
Number of displayed diagnostic buffer entries can be configured in CPU RUN mode	X ¹	X	X	X	X	X ¹	X	X	X ¹	X
Reading out the service data	X ¹	X	X	X	X	X ¹	X	X	X ¹	X
Extension of SFC 12 with 2 new modes to trigger the OB 86 during enabling/disabling	-	-	-	X	-	-	X	-	X ¹	X
Copying of 512 bytes with SFC 81	X ¹	X	X	X	X	X ¹	X	X	X ¹	X

CPU	312	312C	313C	313C-2 DP	313C-2 PtP	314	314C-2 DP	314C-2 PtP	315-2 DP	317-2 DP
Increase										
Main memory	X ¹	X	X	X	X	X ¹	X	X	X ¹	X
Performance through shorter command processing times	X ¹	X	X	X	X	X ¹	X	X	X ¹	X
Status information that can be monitored by the status block, in STEP 7 V5.5 or higher	X ¹	X	X	X	X	X ¹	X	X	X ¹	X
Number of blocks that can be monitored by the status block (from 1 to 2)	X ¹	X	X	X	X	X ¹	X	X	X ¹	X
Number of breakpoints from 2 to 4	X ¹	X	X	X	X	X ¹	X	X	X ¹	X
Local data stack	X ¹	X	X	X	X	X ¹	X	X	X ¹	X
Number of block-related messages (Alarm_S) is uniformly limited to 300	X ¹	X	X	X	X	X ¹	X	X	X ¹	X
Number of the bit memories, timers and counters	X ¹	X	-	-	-	-	-	-	-	-
Standardization										
DB sizes: Max. 64 KB	X ^{1,3}	X	X	X	X	X ¹	X	X	X ¹	X ¹
Watchdog interrupts: OB 32 to OB 35	X ¹	X	X	X	X	X ¹	X	X	X ¹	X ¹
Global data communication of 8 GD circles	X ¹	X	X	X	X	X ¹	X	X	X ¹	X ¹
System function blocks for integrated technology functions:										
SFB 41 to 43	-	-	X ¹	X ¹	X ¹	-	X ¹	X ¹	-	-
SFB 44 and 46	-	-	-	-	-	-	X ¹	X ¹	-	-
SFB 47 to 49	-	X ¹	X ¹	X ¹	X ¹	-	X ¹	X ¹	-	-
SFB 60 to 62	-	-	-	-	X ¹	-	-	X ¹	-	-
SFB 63 to 65	-	-	-	-	-	-	-	X ¹	-	-
¹ This function was already made available to the CPU in an earlier version ² Available, but without function ³ Max. DB size 32 KB										

Standards and certifications

For information about standards and approvals, see the section "General technical specifications (Page 201)".

Recycling and disposal

Because they have ecologically compatible components, the devices described in this manual can be recycled. For environment-friendly recycling and disposal of your old equipment, contact a certified disposal facility for electronic scrap.

Service & Support on the Internet

In addition to our documentation, we offer a comprehensive knowledge base online on the Internet (<http://www.siemens.com/automation/service&support>).

There you will find:

- Our newsletter containing up-to-date information on your products
- The latest documents in the Siemens Service & Support (<http://www.siemens.com/automation/service&support>) search engine.
- A forum for global information exchange by users and specialists.
- Your local representative for automation and drives in our contact database
- Information about on-site services, repairs, spare parts, and lots more.
- Applications and tools for the optimized use of the SIMATIC S7. For example, Siemens also publishes DP and PN performance measurements on the Internet (<http://www.siemens.com/automation/pd>).

ماكان كنترول



ماکان کنترول

Table of contents

	Preface	3
1	Guide to the S7-300 documentation	13
1.1	Documentation classification	13
1.2	Guide to the S7-300 documentation	18
2	Operator controls and indicators	21
2.1	Operator controls and indicators of the compact CPUs (CPU 31xC)	21
2.1.1	Operator controls and indicators: CPU 312C	21
2.1.2	Operator controls and indicators: CPU 313C	24
2.1.3	Operator controls and indicators: CPU 313C-2 PtP	27
2.1.4	Operator controls and indicators: CPU 313C-2 DP	30
2.1.5	Operator controls and indicators: CPU 314C-2 PtP	33
2.1.6	Operator controls and indicators: CPU 314C-2 DP	37
2.1.7	Operator controls and indicators: CPU 314C-2 PN/DP	41
2.2	Operator controls and indicators of the standard CPUs (CPU 31x)	45
2.2.1	Operator controls and indicators: CPU 312 and CPU 314	45
2.2.2	Operator controls and indicators: CPU 315-2 DP and CPU 317-2 DP	47
2.2.3	Operator controls and indicators: CPU 315-2 PN/DP and CPU 317-2 PN/DP	50
2.2.4	Operator controls and indicators: CPU 319-3 PN/DP	52
3	Communication	57
3.1	Interfaces	57
3.1.1	Multi-Point Interface (MPI)	57
3.1.2	PROFIBUS DP	58
3.1.3	PROFINET	59
3.1.3.1	Configuring the port properties	63
3.1.4	Point-to-point (PtP)	64
3.2	Communication services	65
3.2.1	Overview of communication services	65
3.2.2	PG communication	67
3.2.3	OP communication	68
3.2.4	S7 basic communication	68
3.2.5	S7 communication	69
3.2.6	Global data communication (MPI only)	70
3.2.7	Routing	71
3.2.8	Data record routing	75
3.2.9	Clock synchronization	77
3.2.10	Point-to-point connection	79
3.2.11	Data consistency	79
3.3	SNMP communication service	80
3.4	Open communication via Industrial Ethernet	81

3.5	S7 connections.....	84
3.5.1	S7 connection as communication path	84
3.5.2	Allocation of S7 connections	85
3.5.3	Distribution and availability of S7 connection resources.....	87
3.5.4	Connection resources for routing.....	89
3.6	DPV1	91
3.7	Web server	93
3.7.1	Language settings	95
3.7.2	Settings in HW Config, "Web" tab	97
3.7.3	Updating and storing information	100
3.7.4	Web pages	101
3.7.4.1	Start page with general CPU information.....	101
3.7.4.2	Identification	103
3.7.4.3	Diagnostic buffer	104
3.7.4.4	Module information.....	106
3.7.4.5	Messages	113
3.7.4.6	Communication	114
3.7.4.7	Topology.....	120
3.7.4.8	Status of the variables.....	127
3.7.4.9	Variable tables	128
3.7.4.10	User pages	131
4	PROFINET	135
4.1	Communication via PROFINET	135
4.1.1	Introduction	135
4.1.2	PROFINET IO System	138
4.1.3	Blocks for PROFINET IO	140
4.2	Isochronous real-time communication	143
4.3	Prioritized startup	144
4.4	Device replacement without removable medium/programming device	145
4.5	IO devices changing at runtime	145
4.6	Isochronous mode.....	146
4.7	I-Device	146
4.8	Shared Device.....	147
4.9	Media redundancy.....	148
5	Memory concept	149
5.1	Memory areas and retentivity.....	149
5.1.1	CPU memory areas.....	149
5.1.2	Retentivity of load memory, system memory, and main memory	150
5.1.3	Retentivity of memory objects	151
5.1.4	Address areas of the system memory	153
5.1.5	Properties of the SIMATIC Micro Memory Card	158

5.2	Memory functions.....	159
5.2.1	General: Memory functions.....	159
5.2.2	Download of the user program to the SIMATIC Micro Memory Card in the CPU	160
5.2.3	Handling with blocks	161
5.2.3.1	Encryption of blocks.....	161
5.2.3.2	Reloading or transferring blocks	162
5.2.3.3	Uploading blocks.....	163
5.2.3.4	Deleting blocks.....	163
5.2.3.5	Compressing blocks.....	163
5.2.3.6	Promming (RAM to ROM).....	163
5.2.4	Memory reset and restart.....	164
5.2.5	Recipes	165
5.2.6	Measured value log files	167
5.2.7	Backup of project data to SIMATIC Micro Memory Card.....	169
6	Cycle and response times.....	171
6.1	Overview	171
6.2	Cycle time	172
6.2.1	Overview: Cycle time	172
6.2.2	Calculating the cycle time	174
6.2.3	Different cycle times.....	178
6.2.4	Communication load	180
6.2.5	Cycle time extension as a result of test and commissioning functions.....	182
6.2.6	Cycle extension through Component Based Automation (CBA)	183
6.3	Response time	187
6.3.1	Overview: Response time	187
6.3.2	Shortest response time	189
6.3.3	Longest response time.....	190
6.3.4	Reducing the response time using I/O accesses.....	191
6.4	Calculating method for calculating the cycle/response time	192
6.5	Sample calculations for the cycle and response times	193
6.6	Interrupt response time	196
6.6.1	Overview: Interrupt response time	196
6.6.2	Reproducibility of time-delay and watchdog interrupts	198
6.7	Example of interrupt response time calculation	199
7	General technical specifications	201
7.1	Standards and certifications.....	201
7.2	Electromagnetic compatibility	206
7.3	Transportation and storage conditions for modules.....	208
7.4	Mechanical and climatic environmental conditions for S7-300 operation.....	209
7.5	Specification of dielectric tests, protection class, degree of protection, and rated voltage of S7-300.....	211
7.6	Rated voltages of S7-300	211

8	Technical specifications of CPU 31xC	213
8.1	General technical specifications	213
8.1.1	Dimensions of CPU 31xC	213
8.1.2	Technical specifications of the Micro Memory Card	214
8.2	CPU 312C	215
8.3	CPU 313C	224
8.4	CPU 313C-2 PtP and CPU 313C-2 DP	233
8.5	CPU 314C-2 PtP and CPU 314C-2 DP	245
8.6	CPU 314C-2 PN/DP	257
8.7	Technical specifications of the onboard I/O	272
8.7.1	Arrangement and usage of integrated inputs/outputs	272
8.7.2	Analog I/O devices	278
8.7.3	Parameterization	283
8.7.4	Interrupts	289
8.7.5	Diagnostics	290
8.7.6	Digital inputs	290
8.7.7	Digital outputs	292
8.7.8	Analog inputs	294
8.7.9	Analog outputs	297
9	Technical specifications of CPU 31x.....	301
9.1	General technical specifications	301
9.1.1	Dimensions of CPU 31x	301
9.1.2	Technical specifications of the SIMATIC Micro Memory Card.....	302
9.2	CPU 312.....	303
9.3	CPU 314.....	311
9.4	CPU 315-2 DP	319
9.5	CPU 315-2 PN/DP	329
9.6	CPU 317-2 DP	344
9.7	CPU 317-2 PN/DP	355
9.8	CPU 319-3 PN/DP	370
	Glossary	387
	Index.....	415

Guide to the S7-300 documentation

1.1 Documentation classification

Documentation classification

The documentation listed below is part of the S7-300 documentation package.
You can also find this on the Internet and the corresponding entry ID.

Name of the documentation	Description
Manual CPU 31xC and CPU 31x: Technical specifications Entry ID: 12996906 http://support.automation.siemens.com/WW/view/en/12996906	Description of: <ul style="list-style-type: none"> • Operator controls and indicators • Communication • Memory concept • Cycle and response times • Technical specifications
Operating Instructions CPU 31xC and CPU 31x: Installation Entry ID: 13008499 http://support.automation.siemens.com/WW/view/en/13008499	Description of: <ul style="list-style-type: none"> • Configuring • Installing • Wiring • Addressing • Commissioning • Maintenance and the test functions • Diagnostics and troubleshooting
Operating Instructions CPU 31xC: Technological functions incl. CD Entry ID: 12429336 http://support.automation.siemens.com/WW/view/en/12429336	Description of the specific technological functions: <ul style="list-style-type: none"> • Positioning • Counting • Point-to-point connection • Rules The CD contains examples of the technological functions.

Name of the documentation	Description
Manual S7-300 Automation System: Module data Entry ID: 8859629 http://support.automation.siemens.com/WW/view/en/8859629	Descriptions and technical specifications of the following modules: <ul style="list-style-type: none"> • Signal modules • Power supplies • Interface modules
List Manual Instruction List of the S7-300 CPUs and ET- 200 CPUs Entry ID: 31977679 http://support.automation.siemens.com/WW/view/en/31977679	<ul style="list-style-type: none"> • List of the instruction set of the CPUs and their execution times. • List of the executable blocks (OBs/SFCs/SFBs) and their execution times.

Additional information

You also require information from the following descriptions:

Name of the documentation	Description
Getting Started S7-300 Automation System: Getting Started CPU 31x: Commissioning Entry ID: 15390497 http://support.automation.siemens.com/WW/view/en/15390497	Description of examples showing the various commissioning phases leading to a functional application.
Getting Started S7-300 Automation System: Getting Started CPU 31xC: Commissioning Entry ID: 48077635 http://support.automation.siemens.com/WW/view/en/48077635	Description of examples showing the various commissioning phases leading to a functional application.
Getting Started First steps in commissioning CPU 31xC: Positioning with analog output Entry ID: 48070939 http://support.automation.siemens.com/WW/view/en/48070939	Description of examples showing the various commissioning phases leading to a functional application.
Getting Started First steps in commissioning CPU 31xC: Positioning with digital output Entry ID: 48077520 http://support.automation.siemens.com/WW/view/en/48077520	Description of examples showing the various commissioning phases leading to a functional application.

Name of the documentation	Description
<p>Getting Started First steps in commissioning CPU 31xC: Counting Entry ID: 48064324 http://support.automation.siemens.com/WW/view/en/48064324</p>	Description of examples showing the various commissioning phases leading to a functional application.
<p>Getting Started First steps in commissioning CPU 31xC: Point-to-point connection Entry ID: 48064280 http://support.automation.siemens.com/WW/view/en/48064280</p>	Description of examples showing the various commissioning phases leading to a functional application.
<p>Getting Started First steps in commissioning CPU 31xC: Rules Entry ID: 48077500 http://support.automation.siemens.com/WW/view/en/48077500</p>	Description of examples showing the various commissioning phases leading to a functional application.
<p>Getting Started CPU315-2 PN/DP, 317-2 PN/DP, 319-3 PN/DP: Configuring the PROFINET interface Entry ID: 48080216 http://support.automation.siemens.com/WW/view/en/48080216</p>	Description of examples showing the various commissioning phases leading to a functional application.
<p>Getting Started CPU 317-2 PN/DP: Configuring an ET 200S as PROFINET IO device Entry ID: 19290251 http://support.automation.siemens.com/WW/view/en/19290251</p>	Description of examples showing the various commissioning phases leading to a functional application.
<p>Reference Manual System and standard functions for S7-300/400, volume 1/2 Entry ID: 1214574 http://support.automation.siemens.com/WW/view/en/1214574</p>	<p>Overview of objects included in the operating systems for S7-300 and S7-400 CPUs:</p> <ul style="list-style-type: none"> • OBs • SFCs • SFBs • IEC functions • Diagnostics data • System status list (SSL) • Events <p>This manual is part of the STEP 7 reference information. You can also find the description in the STEP 7 Online Help.</p>

Name of the documentation	Description
<p>Manual Programming with STEP 7 Entry ID: 18652056 http://support.automation.siemens.com/WW/view/en/18652056</p>	<p>This manual provides a complete overview of programming with the STEP 7 Standard Package. This manual is part of the STEP 7 Standard Package basic information. You can also find a description in the STEP 7 Online Help.</p>
<p>System Manual PROFINET System Description Entry ID: 19292127 http://support.automation.siemens.com/WW/view/en/19292127</p>	<p>Basic description of PROFINET:</p> <ul style="list-style-type: none"> • Network components • Data exchange and communication • PROFINET IO • Component Based Automation • Application example of PROFINET IO and Component Based Automation
<p>Programming manual From PROFIBUS DP to PROFINET IO Entry ID: 19289930 http://support.automation.siemens.com/WW/view/en/19289930</p>	<p>Guideline for the migration from PROFIBUS DP to PROFINET I/O.</p>
<p>Manual SIMATIC NET: Twisted Pair and Fiber-Optic Networks Entry ID: 8763736 http://support.automation.siemens.com/WW/view/en/8763736</p>	<p>Description of:</p> <ul style="list-style-type: none"> • Industrial Ethernet networks • Network configuration • Components • Guidelines for setting up networked automation systems in buildings, etc.
<p>Configuring Manual Configure SIMATIC iMap plants Entry ID: 22762190 http://support.automation.siemens.com/WW/view/en/22762190</p>	<p>Description of the SIMATIC iMap configuration software</p>
<p>Configuring Manual SIMATIC iMap STEP 7 AddOn, create PROFINET components Entry ID: 22762278 http://support.automation.siemens.com/WW/view/en/22762278</p>	<p>Descriptions and instructions for creating PROFINET components with STEP 7 and for using SIMATIC devices in Component Based Automation</p>

Name of the documentation	Description
Function Manual Isochronous mode Entry ID: 15218045 http://support.automation.siemens.com/WW/view/en/15218045	Description of the system property "Isochronous mode"
System Manual Communication with SIMATIC Entry ID: 1254686 http://support.automation.siemens.com/WW/view/en/1254686	Description of: <ul style="list-style-type: none"> • Basics • Services • Networks • Communication functions • Connecting PGs/OPs • Engineering and configuring in STEP 7

Service & support on the Internet

Information on the following topics can be found on the Internet (<http://www.siemens.com/automation/service>):

- Contacts for SIMATIC (<http://www.siemens.com/automation/partner>)
- Contacts for SIMATIC NET (<http://www.siemens.com/simatic-net>)
- Training (<http://www.sitrain.com>)

See also

Documentation package S7-300
<http://support.automation.siemens.com/WW/view/en/10805159/133300>

ماكان كنترول

1.2 Guide to the S7-300 documentation

Overview

The following tables contain a guide through the S7-300 documentation.

Ambient influence on the automation system

Information about ...	is available in the manual ...	In Section ...
What provisions do I have to make for automation system installation space?	<ul style="list-style-type: none"> CPU 31xC and CPU 31x: Installation 	Configuring – Component dimensions Mounting – Installing the mounting rail
How do environmental conditions influence the automation system?	<ul style="list-style-type: none"> CPU 31xC and CPU 31x: Installation 	Appendix

Isolation

Information about ...	is available in the manual ...	In Section ...
Which modules can I use if electrical isolation is required between sensors/actuators?	<ul style="list-style-type: none"> CPU 31xC and CPU 31x: Installation Module data 	Configuring – Electrical assembly, protective measures and grounding
Under what conditions do I have to isolate the modules electrically? How do I wire that?	<ul style="list-style-type: none"> CPU 31xC and CPU 31x: Installation 	Configuring – Electrical assembly, protective measures and grounding Wiring
Under which conditions do I have to isolate stations electrically? How do I wire that?	<ul style="list-style-type: none"> CPU 31xC and CPU 31x: Installation 	Configuring – Configuring subnets

Communication between sensors/actuators and the PLC

Information about ...	is available in the manual ...	In Section ...
Which module is suitable for my sensor/actuator?	<ul style="list-style-type: none"> CPU 31xC and CPU 31x: Technical specifications For your signal module 	Technical specifications
How many sensors/actuators can I connect to the module?	<ul style="list-style-type: none"> CPU 31xC and CPU 31x: Technical specifications For your signal module 	Technical specifications
How do I connect my sensors/actuators to the automation system, using the front connector?	<ul style="list-style-type: none"> CPU 31xC and CPU 31x: Installation 	Wiring – Wiring the front connector

Information about ...	is available in the manual ...	In Section ...
When do I need expansion modules (EM) and how do I connect them?	<ul style="list-style-type: none"> CPU 31xC and CPU 31x: Installation 	Configuring – Distribution of modules across multiple racks
How do I mount modules on racks / mounting rails?	<ul style="list-style-type: none"> CPU 31xC and CPU 31x: Installation 	Assembly – Installing modules on the mounting rail

The use of local and distributed IOs

Information about ...	is available in the manual ...	In Section ...
Which range of modules do I want to use?	<ul style="list-style-type: none"> Module data (for centralized IOs/ expansion devices) of the respective peripheral (for distributed IOs/ PROFIBUS DP) 	–

Configuration consisting of the central controller and expansion units

Information about ...	is available in the manual ...	In Section ...
Which rack / mounting rail is most suitable for my application?	<ul style="list-style-type: none"> CPU 31xC and CPU 31x: Installation 	Configuring
Which interface modules (IM) do I need to connect the expansion units to the central controller?	<ul style="list-style-type: none"> CPU 31xC and CPU 31x: Installation 	Configuring – Distribution of modules across multiple racks
What is the right power supply (PS) for my application?	<ul style="list-style-type: none"> CPU 31xC and CPU 31x: Installation 	Configuring

CPU performance

Information about ...	is available in the manual ...	In Section ...
Which memory concept is best suited to my application?	<ul style="list-style-type: none"> CPU 31xC and CPU 31x: Technical specifications 	Memory concept
How do I insert and remove Micro Memory Cards?	<ul style="list-style-type: none"> CPU 31xC and CPU 31x: Installation 	Commissioning – Commissioning modules – Removing / inserting a Micro Memory Card (MMC)
Which CPU meets my demands on performance?	<ul style="list-style-type: none"> S7-300 instruction list: CPU 31xC and CPU 31x 	–
Length of the CPU response / execution times	<ul style="list-style-type: none"> CPU 31xC and CPU 31x: Technical specifications 	–
Which technological functions are implemented?	<ul style="list-style-type: none"> Technological functions 	–
How can I use these technological functions?	<ul style="list-style-type: none"> Technological functions 	–

Communication

Information about ...	is available in the manual ...	In Section ...
Which principles do I have to take into account?	<ul style="list-style-type: none"> CPU 31xC and CPU 31x: Technical specifications Communication with SIMATIC PROFINET System Description 	Communication
Options and resources of the CPU	<ul style="list-style-type: none"> CPU 31xC and CPU 31x: Technical specifications 	Technical specifications
How to use communication processors (CPs) to optimize communication	<ul style="list-style-type: none"> CP Manual 	–
Which type of communication network is best suited to my application?	<ul style="list-style-type: none"> CPU 31xC and CPU 31x: Installation 	Configuring – Configuring subnets
How do I network the various components?	<ul style="list-style-type: none"> CPU 31xC and CPU 31x: Installation 	Configuring – Configuring subnets
What to take into account when configuring PROFINET networks	<ul style="list-style-type: none"> SIMATIC NET, twisted-pair and fiber-optic networks (6GK1970-1BA10-0AA0) 	Network configuration
	<ul style="list-style-type: none"> PROFINET System Description 	Installation and commissioning

Software

Information about ...	is available in the manual ...	In Section ...
Software requirements of my S7-300 system	<ul style="list-style-type: none"> CPU 31xC and CPU 31x: Technical specifications 	Technical specifications

Supplementary features

Information about ...	is available in ...
How can I implement operation and monitoring functions? (Human Machine Interface)	The relevant manual: <ul style="list-style-type: none"> For text-based displays For Operator Panels For WinCC
How to integrate process control modules	<ul style="list-style-type: none"> Respective PCS7 manual
What options are offered by redundant and fail-safe systems?	<ul style="list-style-type: none"> S7-400H – Fault-Tolerant Systems Failsafe systems
Information to be observed when migrating from PROFIBUS DP to PROFINET IO	<ul style="list-style-type: none"> From PROFIBUS DP to PROFINET IO

Operator controls and indicators

2.1 Operator controls and indicators of the compact CPUs (CPU 31xC)

2.1.1 Operator controls and indicators: CPU 312C

Operator controls and indicators of the CPU 312C

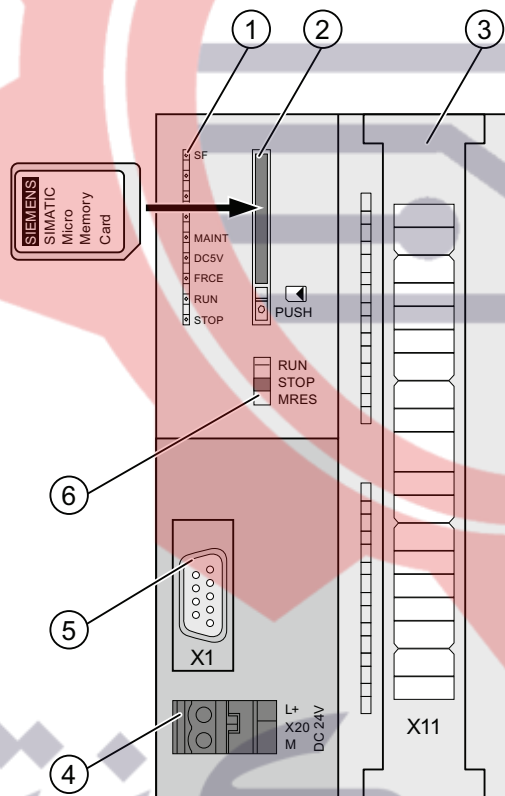

Number	Designation
①	Status and error indicators
②	Slot for the SIMATIC Micro Memory Card incl. the ejector
③	Terminals of the integrated inputs and outputs
④	Power supply connection
⑤	interface X1 (MPI)
⑥	Mode selector

2.1 Operator controls and indicators of the compact CPUs (CPU 31xC)

The figure below shows the integrated digital inputs/outputs of the CPU with open front doors.

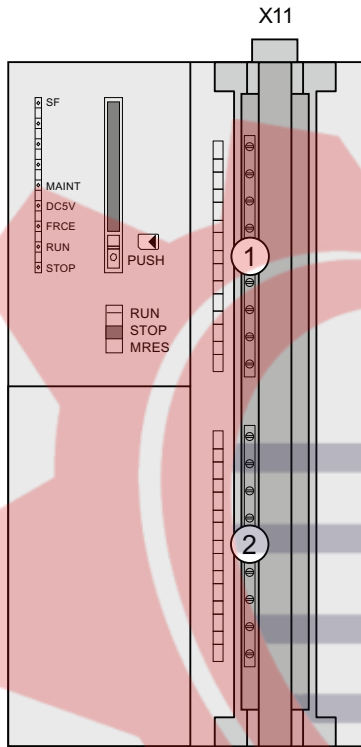

- | Number | Designation |
|--------|---|
| ① | Digital inputs (PIN 2 to 10) |
| ② | Digital input (PIN 11) and digital outputs (PIN 14 to pin 19) |

Status and error indicators

LED designation	Color	Meaning
SF	red	Hardware fault or software error
MAINT	yellow	Maintenance demanded (without function)
DC5V	green	5 V power supply for CPU and S7-300 bus is OK
FRCE	yellow	LED is lit: Active force job LED flashes at 2 Hz: Node flash test function
RUN	green	CPU in RUN mode The LED flashes during start-up at a rate of 2 Hz, and in stop mode at 0.5 Hz
STOP	yellow	CPU in STOP, or HOLD or start-up The LED flashes at a rate of 0.5 Hz when a memory reset is requested, and at 2 Hz during the reset.

Slot for the SIMATIC Micro Memory Card

A SIMATIC Micro Memory Card is used as memory module. You can use an MMC as a load memory and as a portable data carrier.

Note

Since these CPUs do not have an integrated load memory, they require a SIMATIC Micro Memory Card for operation.

Mode selector

Use the mode selector to set the CPU operating mode.

Table 2- 1 Mode selector settings

Setting	Meaning	Explanations
RUN	RUN mode	The CPU executes the user program.
STOP	STOP mode	The CPU does not execute a user program.
MRES	Memory reset	Mode selector setting with pushbutton function for CPU memory reset. A CPU memory reset by means of the mode selector requires a specific sequence of operation.

Power supply connection

All CPUs are equipped with a 2-pin socket for power supply connection. For delivery, the connector with screw terminals is plugged into this inlet at the factory.

Properties of the CPU in relation to interfaces, integrated inputs/outputs and technological functions

Table 2- 2 Properties of the CPUs 312C in relation to interfaces, integrated inputs/outputs and technological functions

Item	CPU 312C
9-pin MPI interface (X1)	Yes
Digital inputs	10
Digital outputs	6
Technological functions	2 counters (See the technological functions manual terminal assignment (http://support.automation.siemens.com/WWW/view/en/26090032))

Reference

- CPU operating state: *STEP 7 online help*
- Information on CPU memory reset: *CPU 31xC and CPU 31x operating instructions, Commissioning, Commissioning Modules, Memory reset by means of Mode Selector of the CPU*
- Evaluation of the LEDs upon error or diagnostic event: *CPU 31xC and CPU 31x Operating Instructions, Test Functions, Diagnostics and Troubleshooting, Diagnostics with the Help of Status and Error LEDs*

2.1.2 Operator controls and indicators: CPU 313C

Operator controls and indicators of the CPU 313C

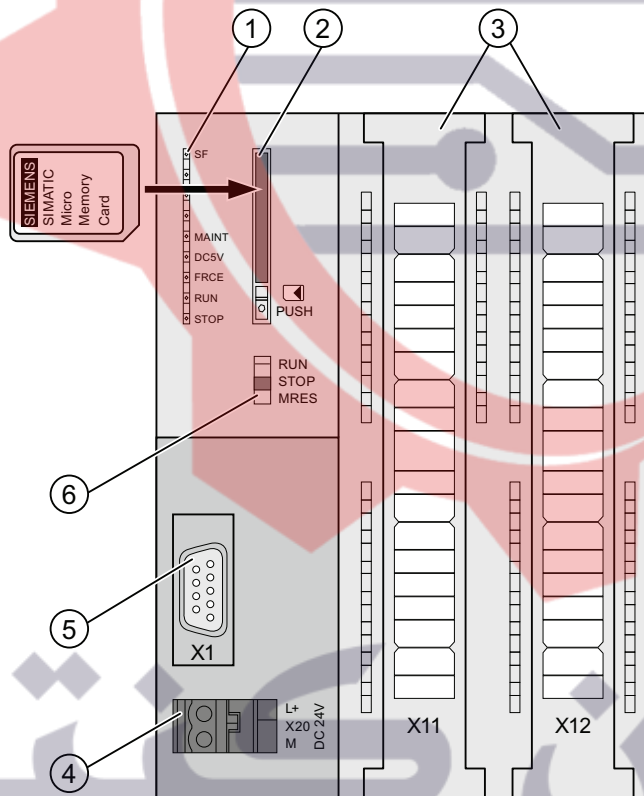

Number	Designation
①	Status and error indicators
②	Slot for the SIMATIC Micro Memory Card incl. the ejector
③	Terminals of the integrated inputs and outputs
④	Power supply connection
⑤	interface X1 (MPI)
⑥	Mode selector

The figure below shows the integrated digital and analog inputs/outputs of the CPU with open front covers.

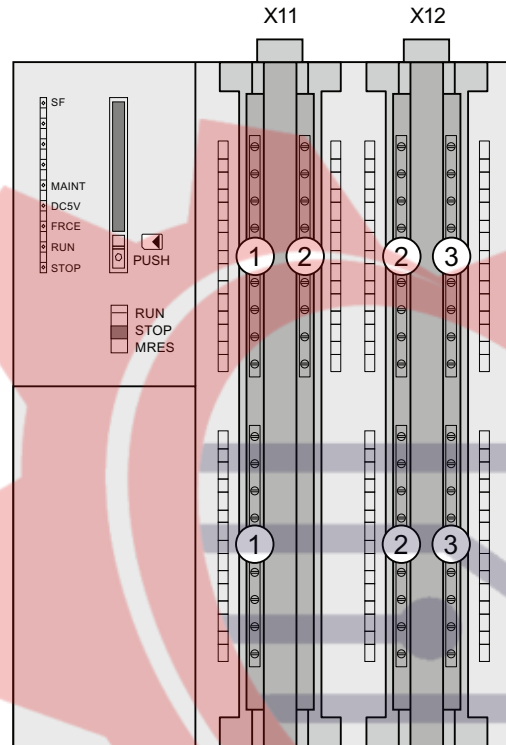

Number	Designation
①	Analog inputs and analog outputs
②	Digital inputs
③	Digital outputs

Status and error indicators

LED designation	Color	Meaning
SF	red	Hardware fault or software error
MAINT	yellow	Maintenance demanded (without function)
DC5V	green	5 V power supply for CPU and S7-300 bus is OK
FRCE	yellow	LED is lit: Active force job LED flashes at 2 Hz: Node flash test function
RUN	green	CPU in RUN mode The LED flashes during start-up at a rate of 2 Hz, and in stop mode at 0.5 Hz
STOP	yellow	CPU in STOP, or HOLD or start-up The LED flashes at a rate of 0.5 Hz when a memory reset is requested, and at 2 Hz during the reset.

Slot for the SIMATIC Micro Memory Card

A SIMATIC Micro Memory Card is used as memory module. You can use an MMC as a load memory and as a portable data carrier.

Note

Since these CPUs do not have an integrated load memory, they require a SIMATIC Micro Memory Card for operation.

Mode selector

Use the mode selector to set the CPU operating mode.

Table 2- 3 Mode selector settings

Setting	Meaning	Explanations
RUN	RUN mode	The CPU executes the user program.
STOP	STOP mode	The CPU does not execute a user program.
MRES	Memory reset	Mode selector setting with pushbutton function for CPU memory reset. A CPU memory reset by means of the mode selector requires a specific sequence of operation.

Power supply connection

All CPUs are equipped with a 2-pin socket for power supply connection. For delivery, the connector with screw terminals is plugged into this inlet at the factory.

Properties of the CPU in relation to interfaces, integrated inputs/outputs and technological functions

Table 2- 4 Properties of the CPUs 313C in relation to interfaces, integrated inputs/outputs and technological functions

Item	CPU 313C
9-pin MPI interface (X1)	Yes
Digital inputs	24
Digital outputs	16
Analog inputs	4 + 1
Analog outputs	2
Technological functions	3 counters (See the technological functions manual terminal assignment (http://support.automation.siemens.com/WW/view/en/26090032))

Reference

- CPU operating state: *STEP 7 online help*
- Information on CPU memory reset: *CPU 31xC and CPU 31x operating instructions, Commissioning, Commissioning Modules, Memory reset by means of Mode Selector of the CPU*
- Evaluation of the LEDs upon error or diagnostic event: *CPU 31xC and CPU 31x Operating Instructions, Test Functions, Diagnostics and Troubleshooting, Diagnostics with the Help of Status and Error LEDs*

2.1.3 Operator controls and indicators: CPU 313C-2 PtP

Operator controls and indicators of the CPU 313C-2 PtP

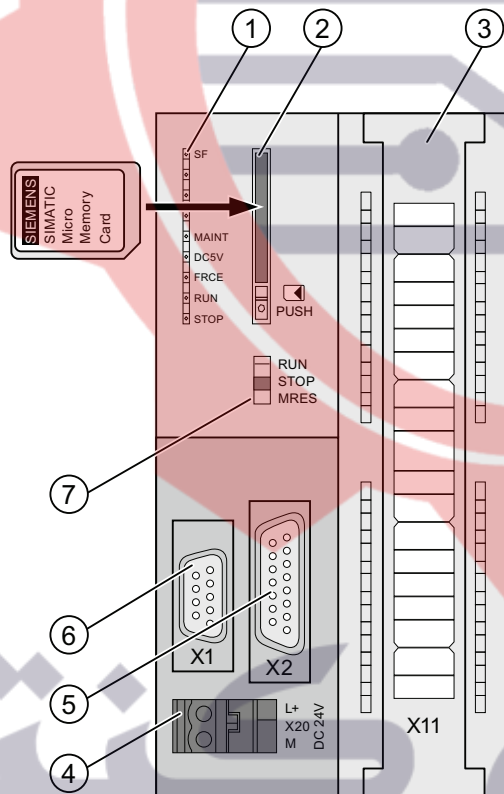

Number	Designation
①	Status and error indicators
②	Slot for the SIMATIC Micro Memory Card incl. the ejector
③	Terminals of the integrated inputs and outputs
④	Power supply connection
⑤	2. Interface X2 (PtP)
⑥	1. interface X1 (MPI)
⑦	Mode selector

2.1 Operator controls and indicators of the compact CPUs (CPU 31xC)

The figure below shows the integrated digital inputs/outputs of the CPU with open front doors.

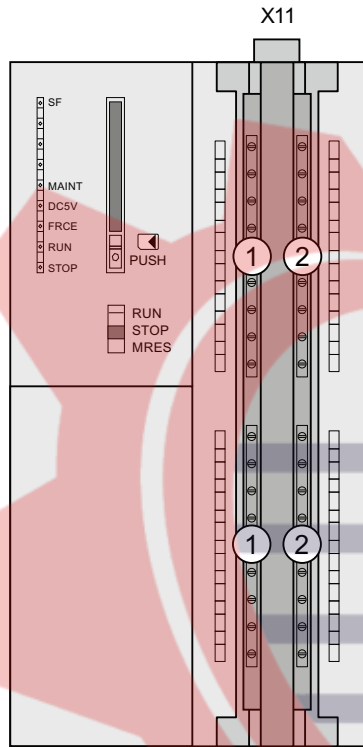

- | Numb | Designation |
|------|-----------------|
| ① | Digital inputs |
| ② | Digital outputs |

Status and error indicators

LED designation	Color	Meaning
SF	red	Hardware fault or software error
MAINT	yellow	Maintenance demanded (without function)
DC5V	green	5 V power supply for CPU and S7-300 bus is OK
FRCE	yellow	LED is lit: Active force job LED flashes at 2 Hz: Node flash test function
RUN	green	CPU in RUN mode The LED flashes during start-up at a rate of 2 Hz, and in stop mode at 0.5 Hz
STOP	yellow	CPU in STOP, or HOLD or start-up The LED flashes at a rate of 0.5 Hz when a memory reset is requested, and at 2 Hz during the reset.

Slot for the SIMATIC Micro Memory Card

A SIMATIC Micro Memory Card is used as memory module. You can use an MMC as a load memory and as a portable data carrier.

Note

Since these CPUs do not have an integrated load memory, they require a SIMATIC Micro Memory Card for operation.

Mode selector

Use the mode selector to set the CPU operating mode.

Table 2- 5 Mode selector settings

Setting	Meaning	Explanations
RUN	RUN mode	The CPU executes the user program.
STOP	STOP mode	The CPU does not execute a user program.
MRES	Memory reset	Mode selector setting with pushbutton function for CPU memory reset. A CPU memory reset by means of the mode selector requires a specific sequence of operation.

Power supply connection

All CPUs are equipped with a 2-pin socket for power supply connection. For delivery, the connector with screw terminals is plugged into this inlet at the factory.

Properties of the CPU in relation to interfaces, integrated inputs/outputs and technological functions

Table 2- 6 Properties of the CPUs 313C-2 PtP in relation to interfaces, integrated inputs/outputs and technological functions

Item	CPU 313C-2 PtP
9-pin MPI interface (X1)	Yes
15-pin PtP interface (X2)	Yes
Digital inputs	16
Digital outputs	16
Technological functions	3 counters Point-to-point connection: <ul style="list-style-type: none"> • ASCII drivers • 3964(R) Protocol (See the technological functions manual terminal assignment (http://support.automation.siemens.com/WW/view/en/26090032))

Reference

- CPU operating state: *STEP 7 online help*
- Information on CPU memory reset: *CPU 31xC and CPU 31x operating instructions, Commissioning, Commissioning Modules, Memory reset by means of Mode Selector of the CPU*
- Evaluation of the LEDs upon error or diagnostic event: *CPU 31xC and CPU 31x Operating Instructions, Test Functions, Diagnostics and Troubleshooting, Diagnostics with the Help of Status and Error LEDs*

2.1.4 Operator controls and indicators: CPU 313C-2 DP

Operator controls and indicators of the CPU 313C-2 DP

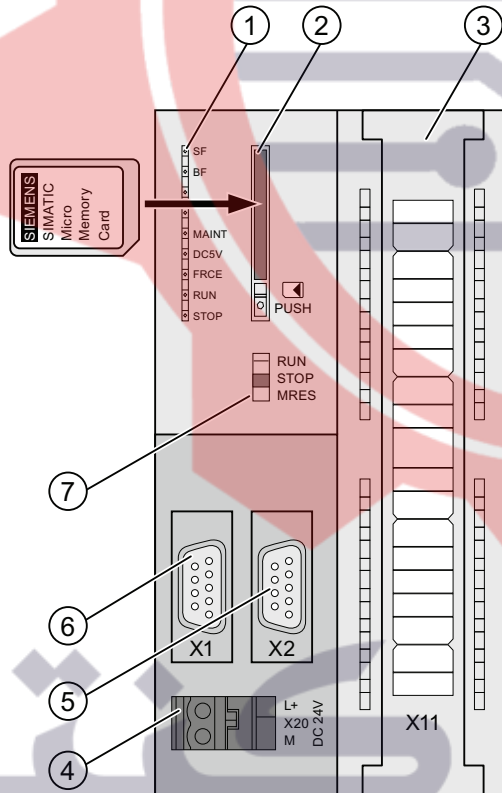

Number	Designation
①	Status and error indicators
②	Slot for the SIMATIC Micro Memory Card incl. the ejector
③	Terminals of the integrated inputs and outputs
④	Power supply connection
⑤	2. interface X2 (DP)
⑥	1. interface X1 (MPI)
⑦	Mode selector

The figure below shows the integrated digital inputs/outputs of the CPU with open front doors.

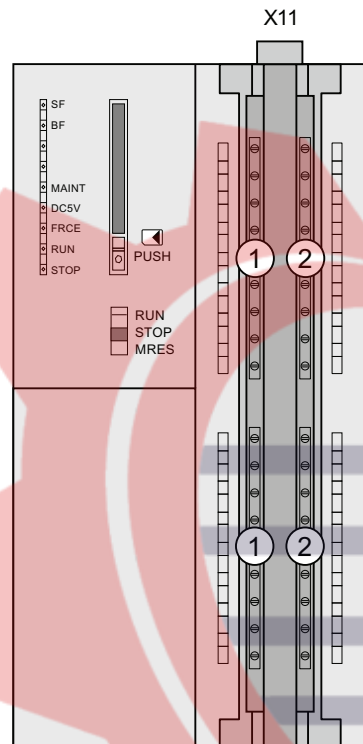

Number	Designation
①	Digital inputs
②	Digital outputs

Status and error indicators

LED designation	Color	Meaning
SF	red	Hardware fault or software error
BF	red	Bus fault
MAINT	yellow	Maintenance demanded (without function)
DC5V	green	5 V power supply for CPU and S7-300 bus is OK
FRCE	yellow	LED is lit: Force job is active LED flashes at 2 Hz: Node flash test function
RUN	green	CPU in RUN mode The LED flashes during start-up at a rate of 2 Hz, and in stop mode at 0.5 Hz
STOP	yellow	CPU in STOP, or HOLD or start-up The LED flashes at a rate of 0.5 Hz when a memory reset is requested, and at 2 Hz during the reset.

Slot for the SIMATIC Micro Memory Card

A SIMATIC Micro Memory Card is used as memory module. You can use an MMC as a load memory and as a portable data carrier.

Note

Since these CPUs do not have an integrated load memory, they require a SIMATIC Micro Memory Card for operation.

Mode selector

Use the mode selector to set the CPU operating mode.

Table 2- 7 Mode selector settings

Setting	Meaning	Explanations
RUN	RUN mode	The CPU executes the user program.
STOP	STOP mode	The CPU does not execute a user program.
MRES	Memory reset	Mode selector setting with pushbutton function for CPU memory reset. A CPU memory reset by means of the mode selector requires a specific sequence of operation.

Power supply connection

All CPUs are equipped with a 2-pin socket for power supply connection. For delivery, the connector with screw terminals is plugged into this inlet at the factory.

Properties of the CPU in relation to interfaces, integrated inputs/outputs and technological functions

Table 2- 8 Properties of the CPU 313C-2 DP in relation to interfaces, integrated inputs/outputs and technological functions

Item	CPU 313C-2 DP
9-pin MPI interface (X1)	Yes
9-pin DP interface (X2)	Yes
Digital inputs	16
Digital outputs	16
Technological functions	3 counters (See the technological functions manual terminal assignment (http://support.automation.siemens.com/WW/view/en/26090032))

Reference

- CPU operating state: *STEP 7 online help*
- Information on CPU memory reset: *CPU 31xC and CPU 31x operating instructions, Commissioning, Commissioning Modules, Memory reset by means of Mode Selector of the CPU*
- Evaluation of the LEDs upon error or diagnostic event: *CPU 31xC and CPU 31x Operating Instructions, Test Functions, Diagnostics and Troubleshooting, Diagnostics with the Help of Status and Error LEDs*

2.1.5 Operator controls and indicators: CPU 314C-2 PtP

Operator controls and indicators of the CPU 314C-2 PtP

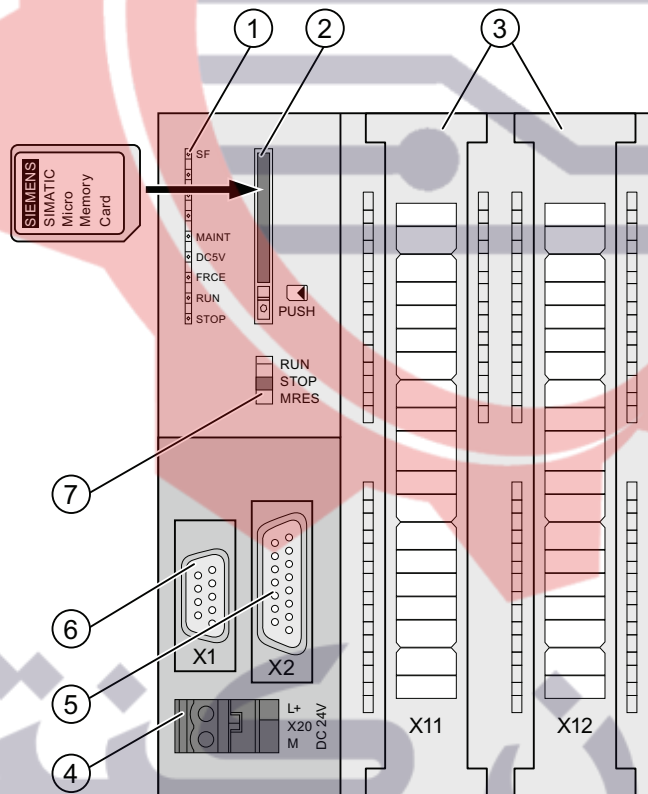

Number	Designation
①	Status and error indicators
②	Slot for the SIMATIC Micro Memory Card incl. the ejector
③	Terminals of the integrated inputs and outputs
④	Power supply connection
⑤	2. Interface X2 (PtP)
⑥	1. interface X1 (MPI)
⑦	Mode selector

2.1 Operator controls and indicators of the compact CPUs (CPU 31xC)

The figure below shows the integrated digital and analog inputs/outputs of the CPU with open front covers.

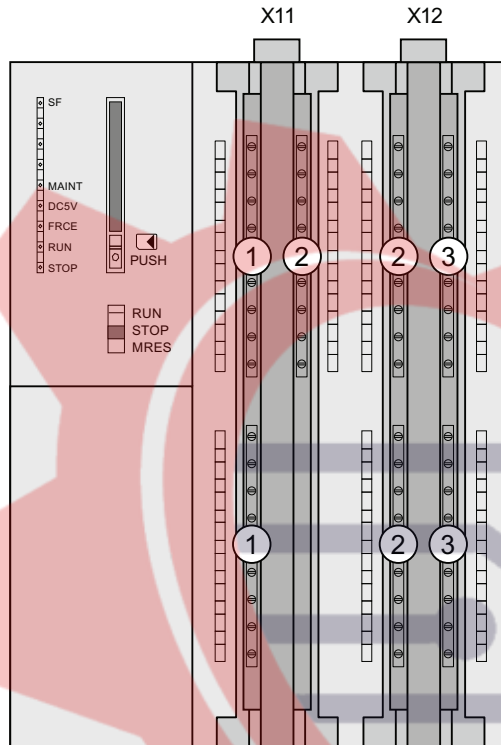

- | Number | Designation |
|--------|----------------------------------|
| ① | Analog inputs and analog outputs |
| ② | Digital inputs |
| ③ | Digital outputs |

Status and error indicators

LED designation	Color	Meaning
SF	red	Hardware fault or software error
MAINT	yellow	Maintenance demanded (without function)
DC5V	green	5 V power supply for CPU and S7-300 bus is OK
FRCE	yellow	LED is lit: Active force job LED flashes at 2 Hz: Node flash test function
RUN	green	CPU in RUN mode The LED flashes during start-up at a rate of 2 Hz, and in stop mode at 0.5 Hz
STOP	yellow	CPU in STOP, or HOLD or start-up The LED flashes at a rate of 0.5 Hz when a memory reset is requested, and at 2 Hz during the reset.

Slot for the SIMATIC Micro Memory Card

A SIMATIC Micro Memory Card is used as memory module. You can use an MMC as a load memory and as a portable data carrier.

Note

Since these CPUs do not have an integrated load memory, they require a SIMATIC Micro Memory Card for operation.

Mode selector

Use the mode selector to set the CPU operating mode.

Table 2- 9 Mode selector settings

Setting	Meaning	Explanations
RUN	RUN mode	The CPU executes the user program.
STOP	STOP mode	The CPU does not execute a user program.
MRES	Memory reset	Mode selector setting with pushbutton function for CPU memory reset. A CPU memory reset by means of the mode selector requires a specific sequence of operation.

Power supply connection

All CPUs are equipped with a 2-pin socket for power supply connection. For delivery, the connector with screw terminals is plugged into this inlet at the factory.

ماکان کنترول

Properties of the CPU in relation to interfaces, integrated inputs/outputs and technological functions

Table 2- 10 Properties of the CPUs 314C-2 PtP in relation to interfaces, integrated inputs/outputs and technological functions

Item	CPU 314C-2 PtP
9-pin MPI interface (X1)	Yes
15-pin PtP interface (X2)	Yes
Digital inputs	24
Digital outputs	16
Analog inputs	4 + 1
Analog outputs	2
Technological functions	4 counters 1 channel for positioning Point-to-point connection: <ul style="list-style-type: none">• ASCII drivers• 3964(R) Protocol• RK 512 (See the technological functions manual terminal assignment (http://support.automation.siemens.com/WWW/view/en/26090032))

Reference

- CPU operating state: *STEP 7 online help*
- Information on CPU memory reset: *CPU 31xC and CPU 31x operating instructions, Commissioning, Commissioning Modules, Memory reset by means of Mode Selector of the CPU*
- Evaluation of the LEDs upon error or diagnostic event: *CPU 31xC and CPU 31x Operating Instructions, Test Functions, Diagnostics and Troubleshooting, Diagnostics with the Help of Status and Error LEDs*

ماکان کنترول

2.1.6 Operator controls and indicators: CPU 314C-2 DP

Operator controls and indicators of the CPU 314C-2 DP

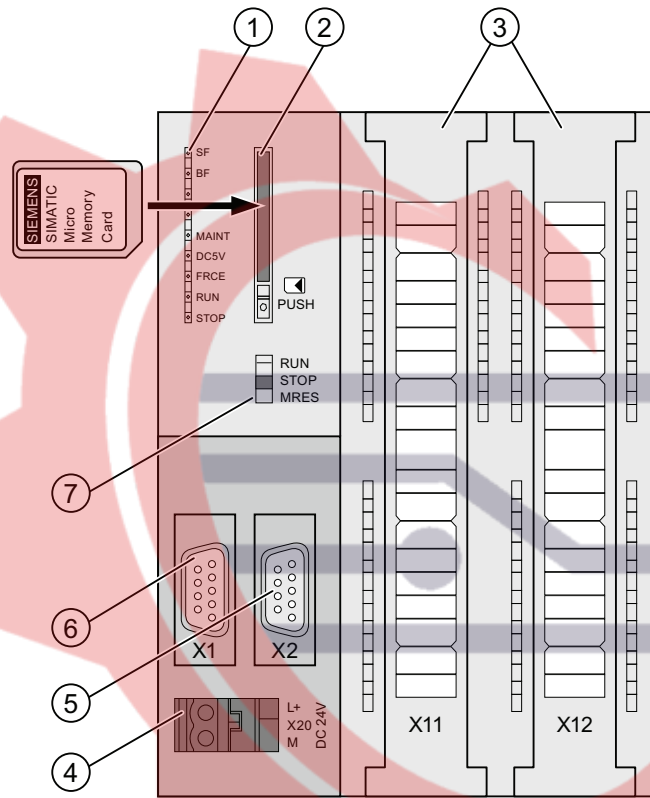

Number	Designation
①	Status and error indicators
②	Slot for the SIMATIC Micro Memory Card incl. the ejector
③	Terminals of the integrated inputs and outputs
④	Power supply connection
⑤	2. interface X2 (DP)
⑥	1. interface X1 (MPI)
⑦	Mode selector

ماكان كنترول

2.1 Operator controls and indicators of the compact CPUs (CPU 31xC)

The figure below shows the integrated digital and analog inputs/outputs of the CPU with open front covers.

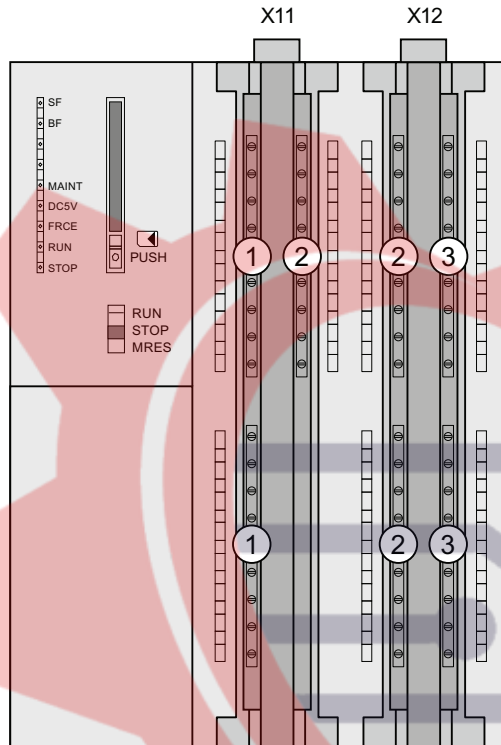

- | Number | Designation |
|--------|----------------------------------|
| ① | Analog outputs and analog inputs |
| ② | Digital inputs |
| ③ | Digital outputs |

Status and error indicators

LED designation	Color	Meaning
SF	red	Hardware fault or software error
BF	red	Bus fault
MAINT	yellow	Maintenance demanded (without function)
DC5V	green	5 V power supply for CPU and S7-300 bus is OK
FRCE	yellow	LED is lit: Active force job LED flashes at 2 Hz: Node flash test function
RUN	green	CPU in RUN mode The LED flashes during start-up at a rate of 2 Hz, and in stop mode at 0.5 Hz
STOP	yellow	CPU in STOP, or HOLD or start-up The LED flashes at a rate of 0.5 Hz when a memory reset is requested, and at 2 Hz during the reset.

Slot for the SIMATIC Micro Memory Card

A SIMATIC Micro Memory Card is used as memory module. You can use an MMC as a load memory and as a portable data carrier.

Note

Since these CPUs do not have an integrated load memory, they require a SIMATIC Micro Memory Card for operation.

Mode selector

Use the mode selector to set the CPU operating mode.

Table 2- 11 Mode selector settings

Setting	Meaning	Explanations
RUN	RUN mode	The CPU executes the user program.
STOP	STOP mode	The CPU does not execute a user program.
MRES	Memory reset	Mode selector setting with pushbutton function for CPU memory reset. A CPU memory reset by means of the mode selector requires a specific sequence of operation.

Power supply connection

All CPUs are equipped with a 2-pin socket for power supply connection. For delivery, the connector with screw terminals is plugged into this inlet at the factory.

Properties of the CPU in relation to interfaces, integrated inputs/outputs and technological functions

Table 2- 12 Properties of the CPUs 314C-2 DP in relation to interfaces, integrated inputs/outputs and technological functions

Item	CPU 314C-2 DP
9-pin MPI interface (X1)	Yes
9-pin DP interface (X2)	Yes
Digital inputs	24
Digital outputs	16
Analog inputs	4 + 1
Analog outputs	2
Technological functions	4 counters 1 channel for positioning (See the technological functions manual terminal assignment (http://support.automation.siemens.com/WW/view/en/26090032))

Reference

- CPU operating state: *STEP 7 online help*
- Information on CPU memory reset: *CPU 31xC and CPU 31x operating instructions, Commissioning, Commissioning Modules, Memory reset by means of Mode Selector of the CPU*
- Evaluation of the LEDs upon error or diagnostic event: *CPU 31xC and CPU 31x Operating Instructions, Test Functions, Diagnostics and Troubleshooting, Diagnostics with the Help of Status and Error LEDs*

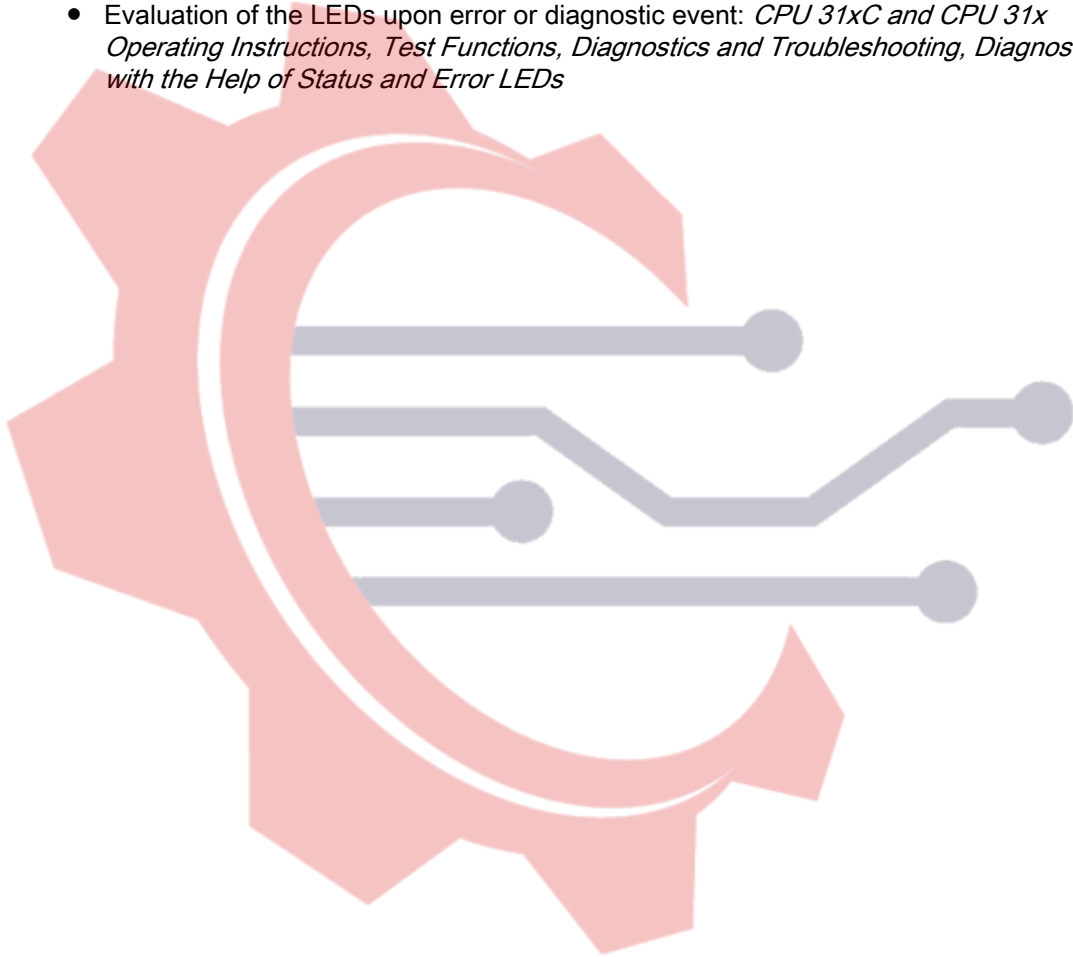

ماكان كنترول

2.1.7 Operator controls and indicators: CPU 314C-2 PN/DP

Operator controls and indicators: CPU 314C-2 PN/DP

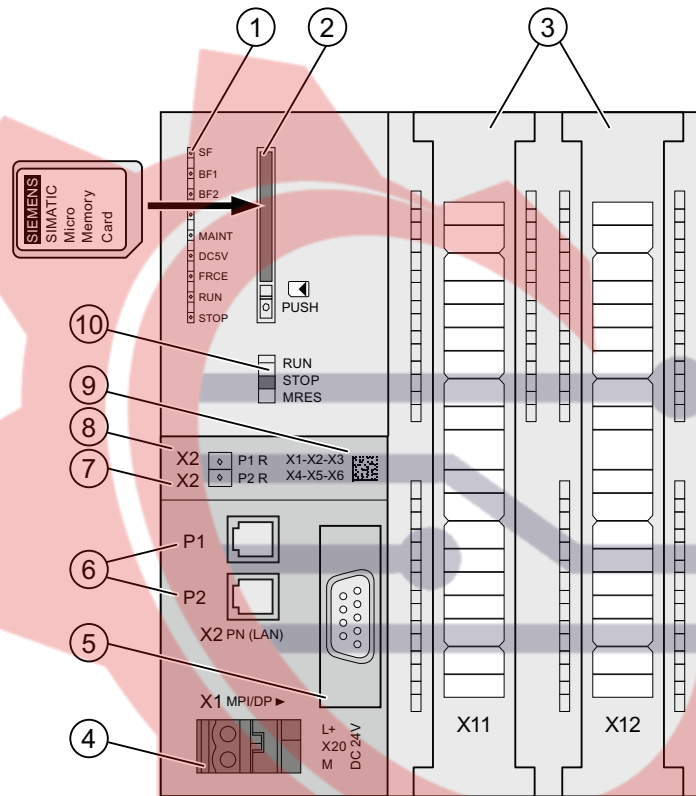

Number	Description
①	Status and error indicators
②	Slot for the SIMATIC Micro Memory Card incl. the ejector
③	Terminals of the integrated inputs and outputs
④	Power supply connection
⑤	1. interface X1 (MPI/DP)
⑥	2. Interface X2 (PN), with dual-port switch
⑦	PROFINET Port 2 The Port 2 status is signaled using a dual-color LED (green/yellow):
	<ul style="list-style-type: none"> • LED lit green: LINK to a partner is active • LED changes to yellow: active data traffic (RX/TX)
⑧	R: Ring port for setting up a ring topology with media redundancy PROFINET Port 1 The Port 1 status is signaled using a dual-color LED (green/yellow):
	<ul style="list-style-type: none"> • LED lit green: LINK to a partner is active • LED changes to yellow: active data traffic (RX/TX)
	R: Ring port for setting up a ring topology with media redundancy
⑨	MAC address and 2D bar code
⑩	Mode selector

2.1 Operator controls and indicators of the compact CPUs (CPU 31xC)

The figure below shows the locations of the integrated digital and analog inputs/outputs of the CPU with open front covers.

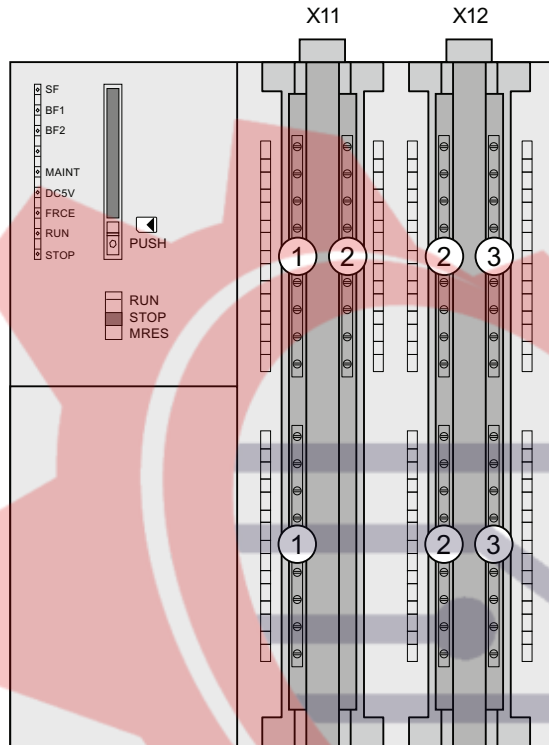

- | Number | Designation |
|--------|----------------------------------|
| ① | Analog inputs and analog outputs |
| ② | Digital inputs |
| ③ | Digital outputs |

Status and error indicators

LED designation	Color	Meaning
SF	red	Hardware fault or software error
BF1	red	Bus error at the first interface (X1)
BF2	red	Bus error at the second interface (X2)
MAINT	yellow	Maintenance demanded status is pending
DC5V	green	5 V power supply for CPU and S7-300 bus is OK
FRCE	yellow	LED is lit: Active force job LED flashes at 2 Hz: Node flash test function
RUN	green	CPU in RUN mode The LED flashes during start-up at a rate of 2 Hz, and in stop mode at 0.5 Hz
STOP	yellow	CPU in STOP, or HOLD or start-up The LED flashes at a rate of 0.5 Hz when a memory reset is requested, and at 2 Hz during the reset.

Slot for the SIMATIC Micro Memory Card

A SIMATIC Micro Memory Card is used as memory module. You can use an MMC as a load memory and as a portable data carrier.

Note

Since these CPUs do not have an integrated load memory, they require a SIMATIC Micro Memory Card for operation.

Mode selector

Use the mode selector to set the CPU operating mode.

Table 2- 13 Mode selector settings

Setting	Meaning	Explanations
RUN	RUN mode	The CPU executes the user program.
STOP	STOP mode	The CPU does not execute a user program.
MRES	Memory reset	Mode selector setting with pushbutton function for CPU memory reset. A CPU memory reset by means of the mode selector requires a specific sequence of operation.

Power supply connection

All CPUs are equipped with a 2-pin socket for power supply connection. For delivery, the connector with screw terminals is plugged into this inlet at the factory.

Properties of the CPU in relation to interfaces, integrated inputs/outputs and technological functions

Table 2- 14 Properties of the CPUs 314C-2 PN/DP in relation to interfaces, integrated inputs/outputs and technological functions

Item	CPU 314C-2 PN/DP
9-pin MPI/DP interface (X1)	Yes
PN interface with 2-port switch (X2)	Yes
Digital inputs	24
Digital outputs	16
Analog inputs	4 + 1
Analog outputs	2
Technological functions	4 counters 1 channel for positioning (see the Technological functions manual terminal assignment (http://support.automation.siemens.com/WW/view/en/26090032))

Reference

- CPU operating state: *STEP 7 online help*
- Information on CPU memory reset: *CPU 31xC and CPU 31x operating instructions, Commissioning, Commissioning Modules, Memory reset by means of Mode Selector of the CPU*
- Evaluation of the LEDs upon error or diagnostic event: *CPU 31xC and CPU 31x Operating Instructions, Test Functions, Diagnostics and Troubleshooting, Diagnostics with the Help of Status and Error LEDs*

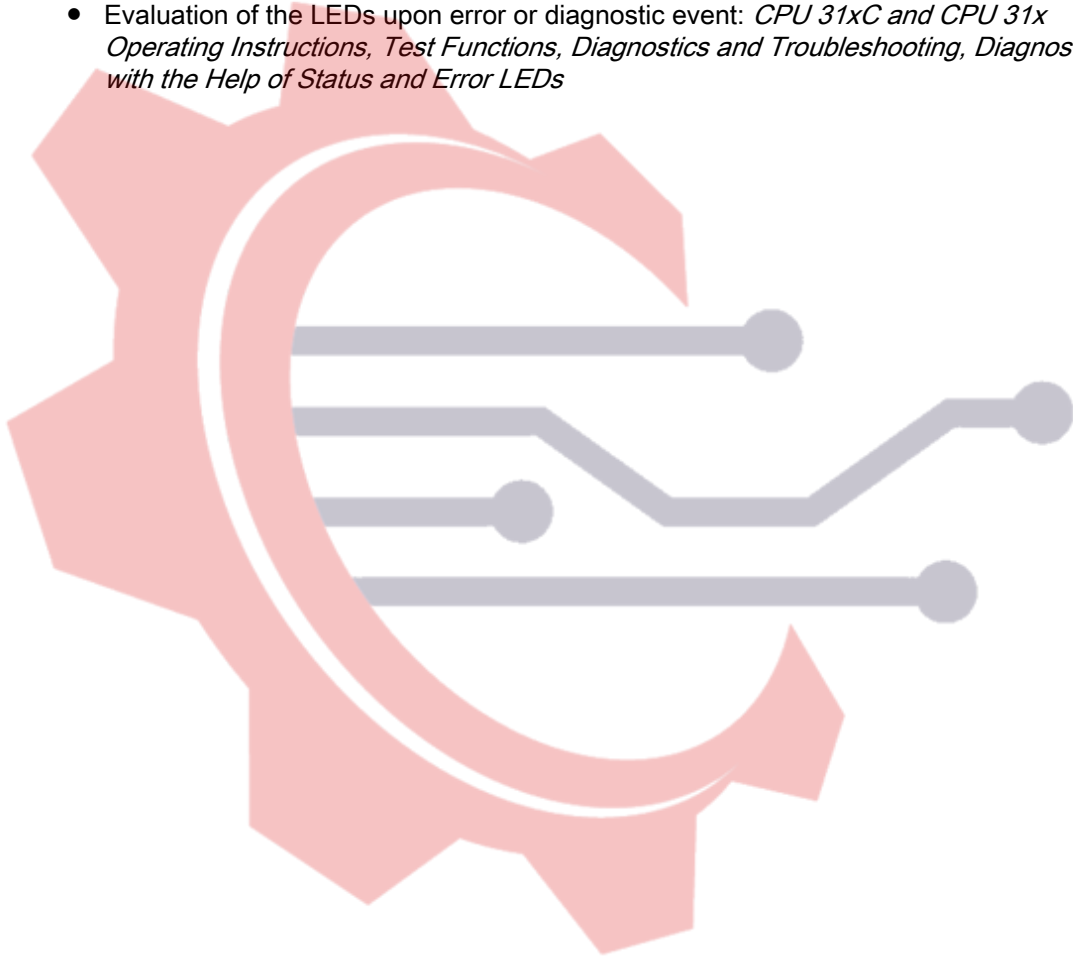

ماكان كنترول

2.2 Operator controls and indicators of the standard CPUs (CPU 31x)

2.2.1 Operator controls and indicators: CPU 312 and CPU 314

Operator controls and indicators of the CPU 312 and CPU 314

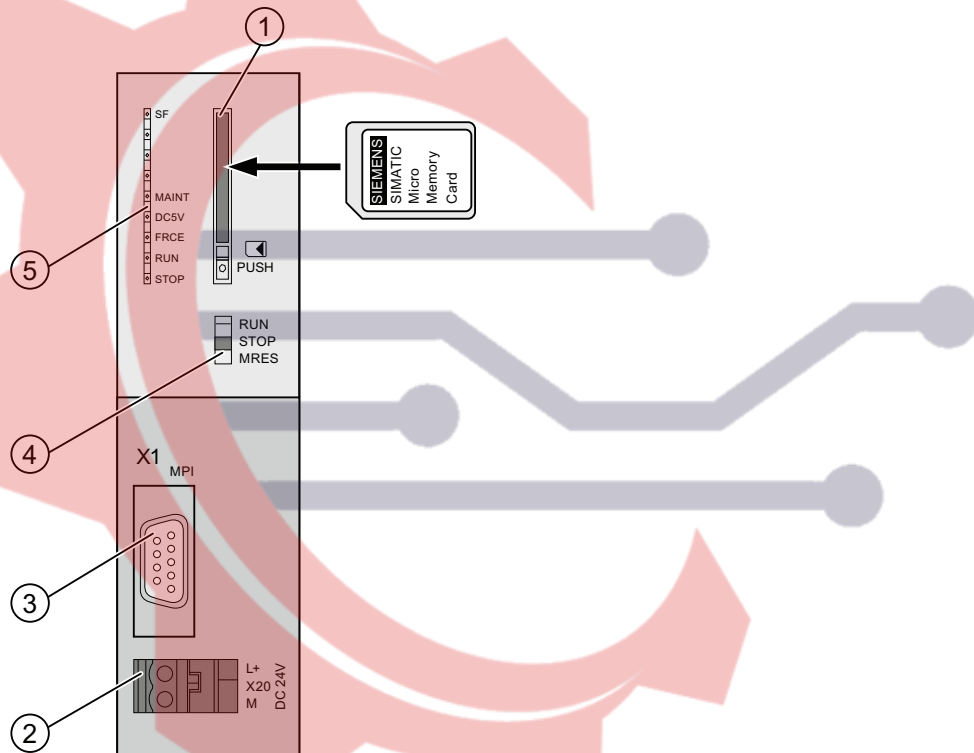

Number	Designation
①	Slot for the SIMATIC Micro Memory Card incl. the ejector
②	Power supply connection
③	interface X1 (MPI)
④	Mode selector
⑤	Status and error indicators

Status and error indicators

LED designation	Color	Meaning
SF	red	Hardware fault or software error
MAINT	yellow	Maintenance demanded (without function)
DC5V	green	5 V power supply for the CPU and S7-300 bus
FRCE	yellow	LED is lit: Active force job LED flashes at 2 Hz: Node flash test function
RUN	green	CPU in RUN The LED flashes during start-up at a rate of 2 Hz, and in stop mode at 0.5 Hz
STOP	yellow	CPU in STOP or HOLD, or STARTUP mode The LED flashes at a rate of 0.5 Hz when a memory reset is requested, and at 2 Hz during the reset.

Slot for the SIMATIC Micro Memory Card

A SIMATIC Micro Memory Card is used as memory module. You can use an MMC as a load memory and as a portable data carrier.

Note

Since these CPUs do not have an integrated load memory, they require a SIMATIC Micro Memory Card for operation.

Mode selector

The mode selector switch is used to set the CPU operating mode.

Table 2- 15 Mode selector settings

Setting	Meaning	Explanations
RUN	RUN mode	The CPU executes the user program.
STOP	STOP mode	The CPU does not execute a user program.
MRES	Memory reset	Mode selector setting with pushbutton function for CPU memory reset. A CPU memory reset by means of the mode selector requires a specific sequence of operation.

Power supply connection

All CPUs are equipped with a 2-pin socket for power supply connection. For delivery, the connector with screw terminals is plugged into this inlet at the factory.

Reference

- CPU operating state: *STEP 7 online help*
- Information on CPU memory reset: *CPU 31xC and CPU 31x operating instructions, Commissioning, Commissioning Modules, Memory reset by means of Mode Selector of the CPU*
- Evaluation of the LEDs upon error or diagnostic event: *CPU 31xC and CPU 31x Operating Instructions, Test Functions, Diagnostics and Troubleshooting, Diagnostics with the Help of Status and Error LEDs*

2.2.2 Operator controls and indicators: CPU 315-2 DP and CPU 317-2 DP

Operator controls and indicators of CPU 315-2 DP and CPU 317-2 DP

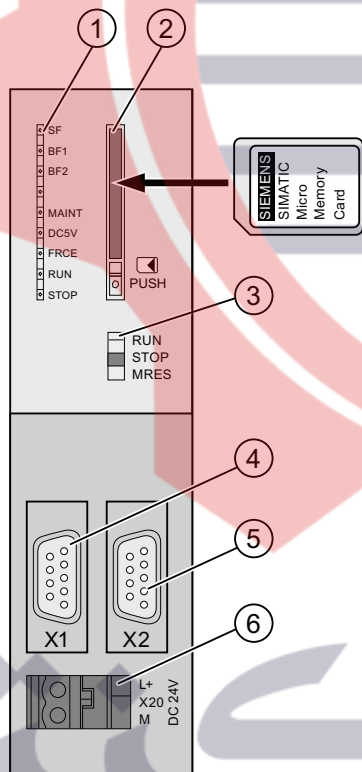

Number	Description
①	Status and error indicators: CPU 315-2 DP has only one bus fault LED: BF CPU 317-2 DP has two bus fault LEDs: BF1 and BF 2
②	Slot for the SIMATIC Micro Memory Card incl. the ejector
③	Mode selector
④	1. Interface X1 (MPI for CPU 315-2 DP, MPI/DP for CPU 317-2 DP)
⑤	2. interface X2 (DP)
⑥	Power supply connection

Status and error indicators of the CPU 315-2 DP

LED designation	Color	Meaning
SF	red	Hardware fault or software error
BF	red	Bus error at the DP interface (X2)
MAINT	yellow	Maintenance demanded (without function)
DC5V	green	5 V power supply for the CPU and S7-300 bus
FRCE	yellow	LED is lit: Active force job LED flashes at 2 Hz: Node flash test function
RUN	green	CPU in RUN The LED flashes during start-up at a rate of 2 Hz, and in stop mode at 0.5 Hz
STOP	yellow	CPU in STOP or HOLD, or STARTUP mode The LED flashes at a rate of 0.5 Hz when a memory reset is requested, and at 2 Hz during the reset.

Status and error indicators of the CPU 317-2 DP

LED designation	Color	Meaning
SF	red	Hardware fault or software error
BF1	red	Bus error at the first interface (X1)
BF2	red	Bus error at the second interface (X2)
MAINT	yellow	Maintenance demanded (without function)
DC5V	green	5 V power supply for the CPU and S7-300 bus
FRCE	yellow	LED is lit: Active force job LED flashes at 2 Hz: Node flash test function
RUN	green	CPU in RUN The LED flashes during start-up at a rate of 2 Hz, and in stop mode at 0.5 Hz
STOP	yellow	CPU in STOP or HOLD, or STARTUP mode The LED flashes at a rate of 0.5 Hz when a memory reset is requested, and at 2 Hz during the reset.

Slot for the SIMATIC Micro Memory Card

A SIMATIC Micro Memory Card is used as memory module. You can use an MMC as a load memory and as a portable data carrier.

Note

Since these CPUs do not have an integrated load memory, they require a SIMATIC Micro Memory Card for operation.

Mode selector

Use the mode selector to set the CPU operating mode:

Table 2- 16 Mode selector settings

Setting	Meaning	Explanations
RUN	RUN mode	The CPU executes the user program.
STOP	STOP mode	The CPU does not execute a user program.
MRES	Memory reset	Mode selector setting with pushbutton function for CPU memory reset. A CPU memory reset by means of the mode selector requires a specific sequence of operation.

Power supply connection

All CPUs are equipped with a 2-pin socket for power supply connection. For delivery, the connector with screw terminals is plugged into this inlet at the factory.

Reference

- CPU operating state: *STEP 7 online help*
- Information on CPU memory reset: *CPU 31xC and CPU 31x operating instructions, Commissioning, Commissioning Modules, Memory reset by means of Mode Selector of the CPU*
- Evaluation of the LEDs upon error or diagnostic event: *CPU 31xC and CPU 31x Operating Instructions, Test Functions, Diagnostics and Troubleshooting, Diagnostics with the Help of Status and Error LEDs*

ماکان کنترول

2.2.3 Operator controls and indicators: CPU 315-2 PN/DP and CPU 317-2 PN/DP

Operator controls and indicators of CPU 315-2 PN/DP and CPU 317-2 PN/DP

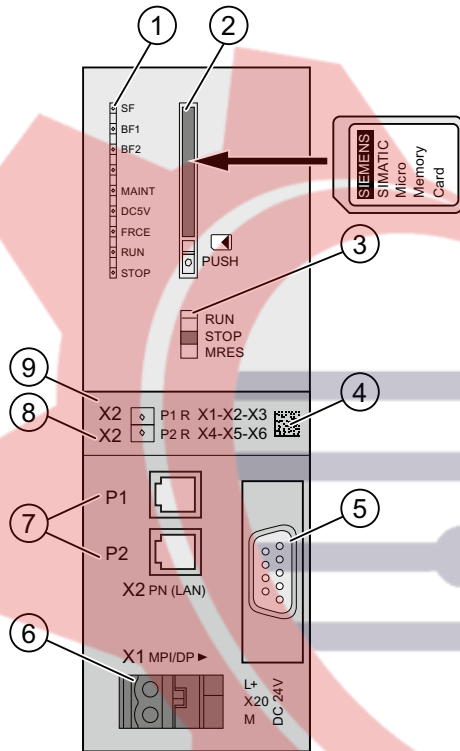

- | Number | Description |
|--------|--|
| ① | Status and error indicators |
| ② | Slot for the SIMATIC Micro Memory Card incl. the ejector |
| ③ | Mode selector |
| ④ | MAC address and 2D bar code |
| ⑤ | 1. interface X1 (MPI/DP) |
| ⑥ | Power supply connection |
| ⑦ | 2. Interface X2 (PN), with dual-port switch |
| ⑧ | PROFINET Port 2
The Port 2 status is signaled using a dual-color LED (green/yellow): |
| | <ul style="list-style-type: none"> • LED lit green: LINK to a partner is active • LED changes to yellow: active data traffic (RX/TX) R: Ring port for setting up a ring topology with media redundancy |
| ⑨ | PROFINET Port 1
The Port 1 status is signaled using a dual-color LED (green/yellow): |
| | <ul style="list-style-type: none"> • LED lit green: LINK to a partner is active • LED changes to yellow: active data traffic (RX/TX) R: Ring port for setting up a ring topology with media redundancy |

Status and error indicators

LED designation	Color	Meaning
SF	red	Hardware fault or software error
BF1	red	Bus error at the first interface (X1)
BF2	red	Bus error at the second interface (X2)
LINK/RX/TX	green	Connection is active at the relevant port
	yellow	Receiving/transmitting data at the relevant port
MAINT	yellow	Maintenance demanded
DC5V	green	5 V power supply for the CPU and S7-300 bus
FRCE	yellow	LED is lit: Active force job LED flashes at 2 Hz: Node flash test function
RUN	green	CPU in RUN The LED flashes during start-up at a rate of 2 Hz, and in stop mode at 0.5 Hz
STOP	yellow	CPU in STOP or HOLD, or STARTUP mode The LED flashes at a rate of 0.5 Hz when a memory reset is requested, and at 2 Hz during the reset.

Slot for the SIMATIC Micro Memory Card

A SIMATIC Micro Memory Card is used as memory module. You can use an MMC as a load memory and as a portable data carrier.

Note

Since these CPUs do not have an integrated load memory, they require a SIMATIC Micro Memory Card for operation.

Mode selector

You can use the mode selector switch to set the current operating mode of the CPU.

Table 2- 17 Mode selector settings

Setting	Meaning	Explanations
RUN	RUN mode	The CPU executes the user program.
STOP	STOP mode	The CPU does not execute a user program.
MRES	Memory reset	Mode selector setting with pushbutton function for CPU memory reset. A CPU memory reset by means of the mode selector requires a specific sequence of operation.

Power supply connection

All CPUs are equipped with a 2-pin socket for power supply connection. For delivery, the connector with screw terminals is plugged into this inlet at the factory.

Reference

- CPU operating state: *STEP 7 online help*
- Information on CPU memory reset: *CPU 31xC and CPU 31x operating instructions, Commissioning, Commissioning Modules, Memory reset by means of Mode Selector of the CPU*
- Evaluation of the LEDs upon error or diagnostic event: *CPU 31xC and CPU 31x Operating Instructions, Test Functions, Diagnostics and Troubleshooting, Diagnostics with the Help of Status and Error LEDs*

2.2.4 Operator controls and indicators: CPU 319-3 PN/DP

Operator controls and indicators

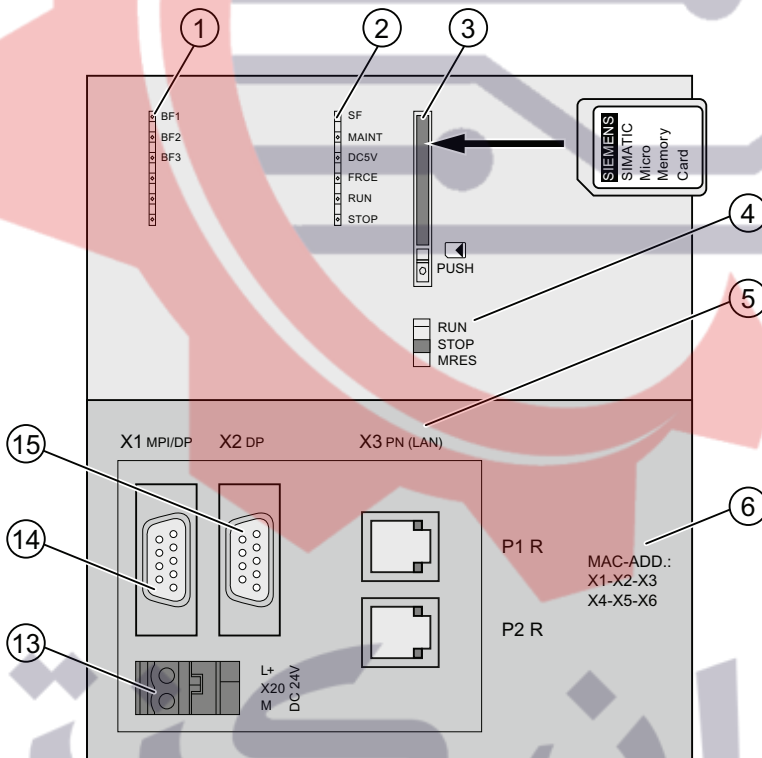

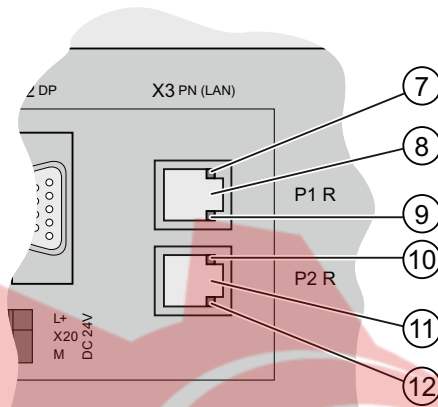

Number	Designation
①	Bus error indicators
②	Status and error indicators
③	Slot for the SIMATIC Micro Memory Card incl. the ejector
④	Mode selector
⑤	3. Interface X3 (PN), with dual-port switch
⑥	MAC address
⑦	Green LED - Port 1 LED designation: LINK LED lit green: LINK to a partner is active
⑧	PROFINET- Port 1 R: Ring port for setting up a ring topology with media redundancy
⑨	Yellow LED - Port 1 LED designation: RX/TX LED lit yellow: active data traffic (RX/TX)
⑩	Green LED - Port 2 LED designation: LINK LED lit green: LINK to a partner is active
⑪	PROFINET- Port 2 R: Ring port for setting up a ring topology with media redundancy
⑫	Yellow LED - Port 2 LED designation: RX/TX LED lit yellow: active data traffic (RX/TX)
⑬	Power supply connection
⑭	1. interface X1 (MPI/DP)
⑮	2. interface X2 (DP)

ماكان سنترل

Status and error indicators

LED designation	Color	Meaning
SF	red	Hardware fault or software error
BF1	red	Bus error at the first interface (X1)
BF2	red	Bus error at the second interface (X2)
BF3	red	Bus error at the third interface (X3)
LINK ¹	green	Connection is active at the relevant port of the third interface (X3)
RX/TX ¹	yellow	Receiving/transmitting data at the relevant port of the third interface (X3)
MAINT	yellow	Maintenance demanded
DC5V	green	5 V power supply for the CPU and S7-300 bus
FRCE	yellow	LED is lit: Active force job LED flashes at 2 Hz: Node flash test function
RUN	green	CPU in RUN The LED flashes during start-up at a rate of 2 Hz, and in stop mode at 0.5 Hz
STOP	yellow	CPU in STOP or HOLD, or STARTUP mode The LED flashes at a rate of 0.5 Hz when a memory reset is requested, and at 2 Hz during the reset.

¹ With the CPU 319-3 PN/DP, the LEDs are located directly at the RJ45 sockets and are not labeled.

Slot for the SIMATIC Micro Memory Card

A SIMATIC Micro Memory Card is used as memory module. You can use an MMC as a load memory and as a portable data carrier.

Note

Since these CPUs do not have an integrated load memory, they require a SIMATIC Micro Memory Card for operation.

Mode selector

You can use the mode selector switch to set the current operating mode of the CPU.

Table 2- 18 Mode selector settings

Setting	Meaning	Explanations
RUN	RUN mode	The CPU executes the user program.
STOP	STOP mode	The CPU does not execute a user program.
MRES	Memory reset	Mode selector setting with pushbutton function for CPU memory reset. A CPU memory reset by means of the mode selector requires a specific sequence of operation.

Power supply connection

All CPUs are equipped with a 2-pin socket for power supply connection. For delivery, the connector with screw terminals is plugged into this inlet at the factory.

Reference

- CPU operating state: *STEP 7 online help*
- Information on CPU memory reset: *CPU 31xC and CPU 31x operating instructions, Commissioning, Commissioning Modules, Memory reset by means of Mode Selector of the CPU*
- Evaluation of the LEDs upon error or diagnostic event: *CPU 31xC and CPU 31x Operating Instructions, Test Functions, Diagnostics and Troubleshooting, Diagnostics with the Help of Status and Error LEDs*

ماكان كنترول



ماكان كنترول

Communication

3.1 Interfaces

3.1.1 Multi-Point Interface (MPI)

Availability

All the CPUs described here are equipped with an MPI interface

A CPU equipped with an MPI/DP interface is configured and supplied as MPI interface.

Properties

The MPI (Multi-Point Interface) represents the CPU interface for PG/OP connections, or for communication on an MPI subnet.

The default baud rate of all CPUs is 187.5 kbps. You can also set 19.2 kbps for communication with an S7-200. Baud rates up to max. 12 Mbps are possible with the CPU 314C-2 PN/DP, CPU 315-2 PN/DP, CPU 317-2 and with the CPU 319-3 PN/DP.

The CPU automatically broadcasts its bus configuration via the MPI interface (the transmission rate, for example). A PG, for example, can thus receive the correct parameters and automatically connect to a MPI subnet.

Devices capable of MPI communication

- PG/PC
- OP/TP
- S7-300 / S7-400 with MPI interface
- S7-200 (only at 19.2 kbps)

NOTICE

You may only connect PGs to an MPI subnet which is in RUN.
Do not connect other stations (for example, OP, TP) to the MPI subnet while the system is running. Otherwise, transferred data might be corrupted as a result of interference, or global data packages may be lost.

Clock synchronization

The CPU's MPI interface supports clock synchronization. Detailed information is available in the *Manual CPU 31x and CPU 31x, Technical specifications, section Clock synchronization*.

3.1.2 PROFIBUS DP

Availability

CPUs with the "DP" have at least one DP interface.

The CPU 314C-2 PN/DP, CPU 315-2 PN/DP and the CPU 317-2 PN/DP feature one MPI/DP interface. The 317-2 DP and 319-3 PN/DP CPUs feature an MPI/DP interface plus an additional DP interface. The factory setting of the CPU's MPI/DP interface is MPI mode. You need to set DP mode in STEP 7 if you want to use the DP interface.

Operating modes for CPUs with two DP interfaces

Table 3- 1 Operating modes for CPUs with two DP interfaces

MPI/DP interface	PROFIBUS DP interface
<ul style="list-style-type: none">• MPI• DP master• DP slave ¹	<ul style="list-style-type: none">• not configured• DP master• DP slave ¹

¹ simultaneous operation of the DP slave on both interfaces is excluded

Properties

The PROFIBUS DP interface is mainly used to connect distributed I/O. PROFIBUS DP allows you to create large subnets, for example.

The PROFIBUS DP interface can be configured for operation in master or slave mode, and supports transmission rates up to 12 Mbps

The CPU broadcasts its bus parameters (transmission rate, for example) via the PROFIBUS DP interface when master mode is set. This functionality automatically provides the correct parameters for online operation of a programming device, for example. In your configuration you can specify to disable bus parameter broadcasting.

Note

(for DP interface in slave mode only)

When you disable the "Test, Commissioning, Routing" check box in the DP interface properties dialog box in STEP 7, the transmission rate settings of the master automatically override corresponding user-specific settings. This disables the routing function at this interface.

Devices capable of PROFIBUS DP communication

- PG/PC
- OP/TP
- DP slaves
- DP master
- Actuators/Sensors
- S7-300/S7-400 with PROFIBUS DP interface

Clock synchronization

Clock synchronization is possible via the CPU's PROFIBUS DP interface. Detailed information is available in the manual *CPU 31x and CPU 31x Manual, Technical specifications, Clock synchronization section*.

Reference

Additional information on the PROFIBUS can be found on the Internet (<http://www.profibus.com>).

3.1.3 PROFINET

CPUs with name suffix "PN" are equipped with a PROFINET interface.

The PROFINET interface on CPU31x PN/DP V3.1 or higher is equipped with an integrated dual-port switch.

Special features of PROFINET devices with integrated switch:

- System configuration in line topology is possible
- You can set up a ring topology using Ports 1 and 2 which are identified as ring ports (P1 R, P2 R)
- Connecting a programming device or an HMI device without additional switch

ماکان کنترول

Compatibility with CPUs < V3.1

You can continue to use your existing CPU configuration even after replacing a CPU < V3.1 with a dual-port CPU.

The following rules apply:

- The Ethernet cable to the RJ45 connector must be inserted in **Port 1** of the new CPU.

Port 1 handles the port configuration of the PROFINET interface within the CPU configuration. Assuming you set up a fixed transmission mode and disabled Autonegotiation in the existing CPU configuration, then Port 1 continues to be used as terminal device port instead of being operated as switch port. The CPU interface continues to function, but as a switch, i.e. the forwarding of the Ethernet frames from one port to the other is ensured

- **Port 2** starts up with default parameters

Special features for migration with unchanged CPU configuration:

- **Port 2** cannot be analyzed because it starts up with default parameters without being assigned a separate diagnostics address

Note

To enable diagnostics and reconfiguration of Port 2 as well (e.g. configuration of interrelations, or of the transmission medium/duplex mode), you must replace the old with the new CPU in HW Config.

Connecting to Industrial Ethernet

You can use the integrated PROFINET interface of the CPU to establish a connection to Industrial Ethernet.

The integrated PROFINET interface of the CPU can be configured via an MPI or the PROFINET interface.

Devices which can be connected via PROFINET (PN)

- PROFINET IO Controller
- PROFINET IO Devices (e.g. IM 151-3 PN interface module in an ET 200S)
- PROFINET CBA components
- S7-300/S7-400 with PROFINET interface (e.g. CPU 317-2 PN/DP or CP 343-1)
- Active network components (a switch, for example)
- PG/PC with Ethernet card
- IE/PB link

Properties of the PROFINET interface

Properties	
IEEE standard	802.3
Connector design	2 X RJ45
	Dual-port switch (CPUs V3.1 or higher)
Transmission rate	Max. 100 Mbps
Media	Twisted Pair Cat5 (100 BASE-TX)
Media redundancy	in accordance with IEC 61158

Note

Networking PROFINET components

The use of switches, rather than hubs, for networking PROFINET components brings about a substantial improvement in decoupling bus traffic and improves runtime performance especially under higher bus load. PROFINET CBA with cyclic PROFINET interconnections requires the use of switches in order to maintain compliance with performance specifications. Full-duplex mode at 100 Mbit is mandatory for cyclic PROFINET interconnections.

PROFINET IO also requires the use of switches and 100 Mbit full-duplex mode. In the case of a PROFINET IO in IRT mode, all the PROFINET devices, including the switches, must be IRT-capable in the synchronization domain.

Addressing the ports

To diagnose the individual ports of a PROFINET interface, these ports must each have a separate diagnostics address. Addressing takes place in HW-Config.

For additional information, refer to the *PROFINET System Description* system manual.

To diagnose any detected problems in the user program, diagnostics messages (error and maintenance information) can be enabled using OB 82 (enable set in HW-Config) and then evaluated, for example, by means of SFB 54. There are also various data records (read-out using SFB 52) and system status lists (read-out using SFC 51) provided for more detailed diagnostics.

Diagnostics is also possible in *STEP 7* (e.g. communication diagnostics, network connection, Ethernet statistics, IP parameters).

Send clock and update time

Controllers and devices can be operated on a PROFINET IO subnet with a uniform send clock. If a device does not support the faster send clock times of a controller, the send clock is adapted to the possible send clock of the device. This means, for example, that devices operating with a send clock of 250 μ s as well as 1 ms can operate on a CPU 319-3 PN/DP (IO controller), which operates with a send clock of 250 μ s.

You can parameterize the update time of devices within a relatively wide range. This again depends on the send clock.

Update times for CPU 31x PN/DP

The following update times can be parameterized:

Real-time communication	Send clock	Update time
For RT:	250 μ s	⇒ 250 μ s to 128 ms
	500 μ s	⇒ 500 μ s to 256 ms
	1 ms	⇒ 1 ms to 512 ms
	2 ms	⇒ 2 ms to 512 ms
	4 ms	⇒ 4 ms to 512 ms
For IRT with "high flexibility" option:	250 μ s	⇒ 250 μ s to 128 ms
	500 μ s	⇒ 500 μ s to 256 ms
	1 ms	⇒ 1 ms to 512 ms
For IRT with "high performance" option:	250 μ s	⇒ 250 μ s to 4 ms
	500 μ s	⇒ 500 μ s to 8 ms
	1 ms	⇒ 1 ms to 16 ms
	2 ms	⇒ 2 ms to 32 ms
	4 ms	⇒ 4 ms to 64 ms

The minimum update time is determined by the number of devices used, by the volume of configured user data, and by the time slice for PROFINET IO communication. STEP 7 automatically makes allowances for these dependencies in your system configuration.

Odd number of send clocks for IRT with "high performance" option:

In addition to the "even-numbered" send clocks (250 μ s, 500 μ s, 1 ms, 2 ms, 4 ms), you can set any multiple of 125 ms as "odd-numbered" send clock in the range from 250 μ s and 4 ms for IRT with "high performance" option: 375 μ s, 625 μ s ... 3.875 ms

For "odd-numbered" send clocks, the following rule applies to all PROFINET IO devices:

- Update time = send clock
- IRT with "high performance" cannot be supplemented by means of RT devices

<p>NOTICE</p> <p>On CPUs with an integrated switch, memory resets/firmware updates/power-offs cause an interruption of communication.</p> <p>Note that the PROFINET interface and integrated switch are shut down during CPU memory reset and firmware updates, or after POWER OFF. At a CPU configured for operation in a line topology, communication is shut down to the following devices.</p>
--

Reference

- For instructions on how to configure the integrated PROFINET interface, refer to the *S7-300, CPU 31xC and CPU 31x Setup operating instructions*.
- For more information about PROFINET functionality, refer to the PROFINET System Description (<http://support.automation.siemens.com/WW/view/en/19292127>).
- For detailed information on Ethernet networks, network configuration and network components, refer to the *SIMATIC NET Manual: Twisted-pair and fiber-optic networks*, on the Internet (<http://support.automation.siemens.com/WW/view/en/8763736>).
- For detailed information on CBA, refer to the *Tutorial Component Based Automation, Commissioning Systems* on the Internet (<http://support.automation.siemens.com/WW/view/en/18403908>).
- Additional information about PROFINET can be found on the Internet (<http://www.profibus.com>).

3.1.3.1 Configuring the port properties

Configuring the port properties of the PROFINET interface in *STEP 7*

The PROFINET interfaces in our devices are preset to "automatic setting" (Autonegotiation). Verify that all devices connected to the PROFINET interface of CPU 31x PN/DP are also set to the "Autonegotiation" mode. This is the default setting of standard PROFINET/Ethernet components.

If you connect a device that does not support the "automatic setting" (Autonegotiation) mode to the PROFINET interface of CPU 31x PN/DP, or select a setting in addition to the "automatic setting" (Autonegotiation) mode, note the following:

- PROFINET IO and PROFINET CBA require operation at 100 Mbps full-duplex, i.e. if the PROFINET interface of CPU 31x PN/DP is used simultaneously for communication on PROFINET IO / CBA and Ethernet, the interface must be set to 100 Mbps full-duplex mode in addition to the "automatic setting" (Autonegotiation).
- If the PROFINET interface of CPU 31x PN/DP is used only for Ethernet communication, 10 Mbps or 100 Mbps full-duplex mode can be set in addition to the "automatic setting" (Autonegotiation). Setting half-duplex mode is not permitted in any situation.

Reason: If "Autonegotiation" is set and a switch that is permanently set to "10 Mbps half-duplex" is connected to the PROFINET interface of CPU 31x PN/DP, the CPU adapts its settings to the partner device settings, that is, communication is actually handled in "10 Mbps half-duplex" mode. However, since PROFINET IO and PROFINET CBA require operation with 100 Mbps full-duplex, this operating mode is not allowed.

Note

For additional information about configuring the ports of IO devices that are to carry out a prioritized startup, refer to the special notes in the *PROFINET System Description*.

Disabling the port of a PROFINET interface

You can disable a port of the PROFINET interface in HW Config of *STEP 7*. By default it is activated.

The CPU cannot be addressed at a disabled port of the PROFINET interface.

Take into account that no communication functions such as programming device/OP functions, open IE communication, or S7 communication are possible via a deactivated port.

Addressing the ports

To diagnose the individual ports of a PROFINET interface, these ports must each have a separate diagnostics address. The addressing is done in HW-Config.

For additional information, refer to the *PROFINET System Description*.

To diagnose any detected problems in the user program, diagnostics messages (error and maintenance information) can be enabled using OB 82 (enable set in HW-Config) and then evaluated, for example, by means of SFB 54. There are also various data records (read-out using SFB 52) and system status lists (read-out using SFC 51) provided for more detailed diagnostics.

Diagnostics is also possible in *STEP 7* (e.g. communication diagnostics, network connection, Ethernet statistics, IP parameters).

3.1.4 Point-to-point (PtP)

Availability

CPUs with the "PtP" name suffix have at least one PtP interface.

Properties

Using the PtP interface of your CPU, you can connect external devices with serial interface. You can operate such a system at transmission rates up to 19.2 kbps in full duplex mode (RS 422), and up to 38.4 kbps in half duplex mode (RS 485).

Baud rate

- Half duplex: 38,4 kbps
- Full duplex: 19,2 kbps

Drivers

PtP communication drivers installed in those CPUs:

- ASCII drivers
- 3964(R) Protocol
- RK 512 (CPU 314C-2 PtP only)

Devices capable of PtP communication

Devices equipped with a serial port, for example, barcode readers, printers, etc.

Reference

CPU 31xC: Technological functions manual

3.2 Communication services

3.2.1 Overview of communication services

Selecting the communication service

You need to decide on a communication service based on the required functionality. Your choice of communication service determines

- the available functionality
- whether an S7 connection is required or not
- the time of connecting

The user interfaces can vary considerably (SFC, SFB, etc.) and is also determined by the hardware used (SIMATIC CPU, PC, etc.).

ماکان کنترول

Overview of communication services

The table below provides an overview of communication services offered by the CPUs.

Table 3-2 Communication services of the CPUs

Communication service	Functionality	Time at which the S7 connection is established ...	via MPI	via DP	via PtP	via PN
PG communication	Commissioning, test, diagnostics	From the PG, starting when the service is being used	X	X	–	X
OP communication	Operator control and monitoring	From the OP at POWER ON	X	X	–	X
S7 basic communication	Data exchange	Programmed to take place via blocks (SFC parameters)	X	X	–	–
S7 communication	Data exchange in server and client mode: Configuration of connection required	Via active peer at POWER ON	Only as server	Only as server	–	X
Global data communication	Cyclic data exchange (e.g. bit memories)	Does not require an S7 connection	X	–	–	–
Routing of PG functions (only for CPUs with DP or PROFINET interface)	E.g. testing, diagnostics across network boundaries	From the PG, starting when the service is being used	X	X	–	X
Point-to-point connection	Data exchange via serial interface	Does not require an S7 connection	–	–	X	–
PROFIBUS DP	Data exchange between master and slave	Does not require an S7 connection	–	X	–	–
PROFINET CBA	Data exchange by means of component-based communication	Does not require an S7 connection	–	–	–	X
PROFINET IO	Data exchange between IO controllers and the IO devices	Does not require an S7 connection	–	–	–	X
Web server	Diagnostics	Does not require an S7 connection	–	–	–	X
SNMP (Simple Network Management Protocol)	Standard protocol for network diagnostics and parameterization	Does not require an S7 connection	–	–	–	X
Open communication by means of TCP/IP	Data exchange via Industrial Ethernet with TCP/IP protocol (by means of loadable FBs)	Does not require an S7 connection, is programmed to take place via loadable FBs	–	–	–	X
Open communication by means of ISO-on-TCP	Data exchange via Industrial Ethernet with ISO-on-TCP protocol (by means of loadable FBs)	Does not require an S7 connection, is programmed to take place via loadable FBs	–	–	–	X
Open communication by means of UDP	Data exchange via Industrial Ethernet with UDP protocol (by means of loadable FBs)	Does not require an S7 connection, is programmed to take place via loadable FBs	–	–	–	X

Communication service	Functionality	Time at which the S7 connection is established ...	via MPI	via DP	via PtP	via PN
Data record routing	for example, parameterization and diagnostics of field devices on the PROFIBUS DP by an engineering system operated on an MPI or PROFINET interface (e.g. PDM)	Takes place when the parameterization tool accesses the field device	X	X	–	X
Clock synchronization	Broadcast frames	Does not require an S7 connection	X	X	–	–
	NTP protocol	Does not require an S7 connection	–	–	–	X

See also

Distribution and availability of S7 connection resources (Page 87)

Connection resources for routing (Page 89)

3.2.2**PG communication****Properties**

PG communication is used to exchange data between engineering stations (e.g. PG, PC) and SIMATIC modules with communications capability. This service is possible via MPI, PROFIBUS, and Industrial Ethernet subnets. Transition between subnets is also supported.

PG communication provides the functions needed to load programs and configuration data, run tests, and evaluate diagnostic information. These functions are integrated in the operating system of SIMATIC S7 modules.

A CPU can maintain several simultaneous online connections to one or multiple PGs.

ماکان کنترول

3.2.3 OP communication

Properties

Using OP communication, you can exchange data between operator stations (e.g. OP, TP, WinCC) and SIMATIC modules which have communication functionality. This service is possible via MPI, PROFIBUS, and Industrial Ethernet subnets.

OP communication provides functions you require for operator control and monitoring. These functions are integrated in the operating system of SIMATIC S7 modules. A CPU can maintain several simultaneous connections to one or several OPs.

OP communication can be accelerated enormously by activating "prioritized OCM communication" in the CPU's properties dialog. The CPU must support this function (consult the technical specifications of the relevant CPU).

Note

Effects of "prioritized OCM communication"

- Consistency with user program data will be lost. Consistency must be ensured by means of the user program (refer to the "Data consistency (Page 79)" chapter).
 - The cycle time increases.
-

3.2.4 S7 basic communication

Properties

S7 basic communication is used to exchange data between S7 CPUs and the communication-capable SIMATIC modules within an S7 station (acknowledged data exchange). Data is exchanged via non-configured S7 connections. The service is available via the MPI subnet, or within the station to function modules (FM).

S7 basic communication provides the functions you require for data exchange. These functions are integrated into the CPU operating system. The user can utilize this service via the "System function" (SFC) user interface.

Reference

Additional information

- on SFCs can be found in the *instruction list*.
A detailed description is available in the *STEP 7 Online Help or System and Standard Functions Reference Manual*
- on communication is found in the *Communication with SIMATIC manual*

3.2.5 S7 communication

Properties

A CPU can always operate in server or client mode in S7 communication: We distinguish between

- connections configured at one end (for PUT/GET only)
- connections configured at both ends (for USEND, URCV, BSEND, BRCV, PUT, GET)

However, the available functionality depends on the CPU. A CP is therefore required in certain situations.

Table 3- 3 Client and server in S7 communication using connections configured at one end/both ends

CPU	Use in server mode for connections configured at one end	Use in server mode for connections configured at both ends	Use as client
31xC ≥ V1.0.0	Generally possible on MPI/DP interface without programming of user interface	Only possible with CP and loadable FBs	Only possible with CP and loadable FBs
31x ≥ V2.0.0	Generally possible on MPI/DP interface without programming of user interface	Only possible with CP and loadable FBs	Only possible with CP and loadable FBs
31x ≥ V2.2.0	Generally possible on MPI/DP/PN interface without programming of user interface	<ul style="list-style-type: none"> • Possible on PROFINET interface with loadable FBs or • with CP and loadable FBs 	<ul style="list-style-type: none"> • Possible on PROFINET interface with loadable FBs or • with CP and loadable FBs

The user interface is implemented using **standard** function blocks (FBs) from the standard library of STEP 7, under communication blocks.

Reference

For additional information on communication, refer to the *Communication with SIMATIC* manual.

3.2.6 Global data communication (MPI only)

Properties

Global data communication is used for cyclic exchange of global data via MPI subnets (for example, I, Q, M) between SIMATIC S7 CPUs (data exchange without acknowledgement). One CPU sends the data to all CPUs simultaneously in the MPI subnet. This function is integrated in the CPU operating system.

Reduction ratio

The reduction ratio specifies the cyclic intervals for GD communication. You can set the reduction ratio when you configure global data communication in STEP 7. For example, if you set a reduction ratio of 7, global data is transferred only with every 7th cycle. This reduces the CPU load.

Send and receive conditions

Conditions which should be satisfied for communication via GD circles:

- Mandatory for the sender of a GD package:
 $\text{Reduction ratio}_{\text{Transmitter}} \times \text{Cycle time}_{\text{Transmitter}} \geq 60 \text{ ms}$
- Mandatory for the receiver of a GD package:
 $\text{Reduction ratio}_{\text{Receiver}} \times \text{Cycle time}_{\text{Receiver}} < \text{Reduction ratio}_{\text{Transmitter}} \times \text{Cycle time}_{\text{Transmitter}}$

A GD package may be lost if you do not adhere to these conditions. The reasons being:

- The performance capability of the "smallest" CPU in the GD circle
- Global data is transmitted and received asynchronously by the transmitting and receiving stations

If in STEP 7 you set "Transmit after each CPU cycle" and the CPU has a short CPU cycle time (< 60 ms), the operating system might overwrite a GD package of the CPU before it is transmitted. The loss of global data is indicated in the status box of a GD circle if you set this function in STEP 7.

GD resources of the CPUs

Table 3- 4 GD resources of the CPUs

Parameters	All CPUs of the S7-300 product family
Number of GD circles per CPU	Max. 8
GD packages transmitted per GD circle	Max. 1
GD packages transmitted for all GD circles	Max. 8
GD packages received per GD circle	Max. 1
GD packages received for all GD circles	Max. 8
Data length per GD package	Max. 22 bytes
Consistency	Max. 22 bytes
Min. reduction ratio (default)	1 (8)

3.2.7 Routing

Properties

STEP 7 V5.1 + SP4 or higher allows you to access your S7 stations in all subnets with your PG/PC, for example, to

- download user programs
- download a hardware configuration
- perform test and diagnostic functions

Note

If the CPU is used as an intelligent DP slave, the routing function is only available when the DP interface is set active. In STEP 7, activate the Test, Commission Routing checkbox in the properties dialog of the DP interface. For detailed information, refer to the *Programming with STEP 7 manual*, or directly to the *STEP 7 Online Help*.

Routing gateways: MPI - DP

Gateways between subnets are located in the SIMATIC station that is equipped with interfaces to the respective subnets. The figure below shows CPU 1 (DP master) acting as gateway between subnet 1 and 2.

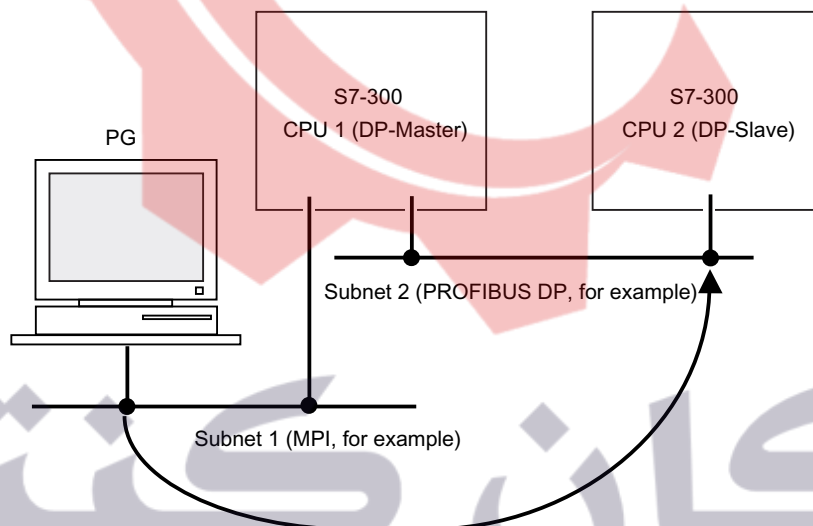

The figure below shows the MPI access to PROFINET via PROFIBUS. CPU 1 (e.g. 315-2 DP) is the gateway between subnet 1 and 2; CPU 2 is the gateway between subnet 2 and 3.

Routing gateways: MPI - DP - PROFINET

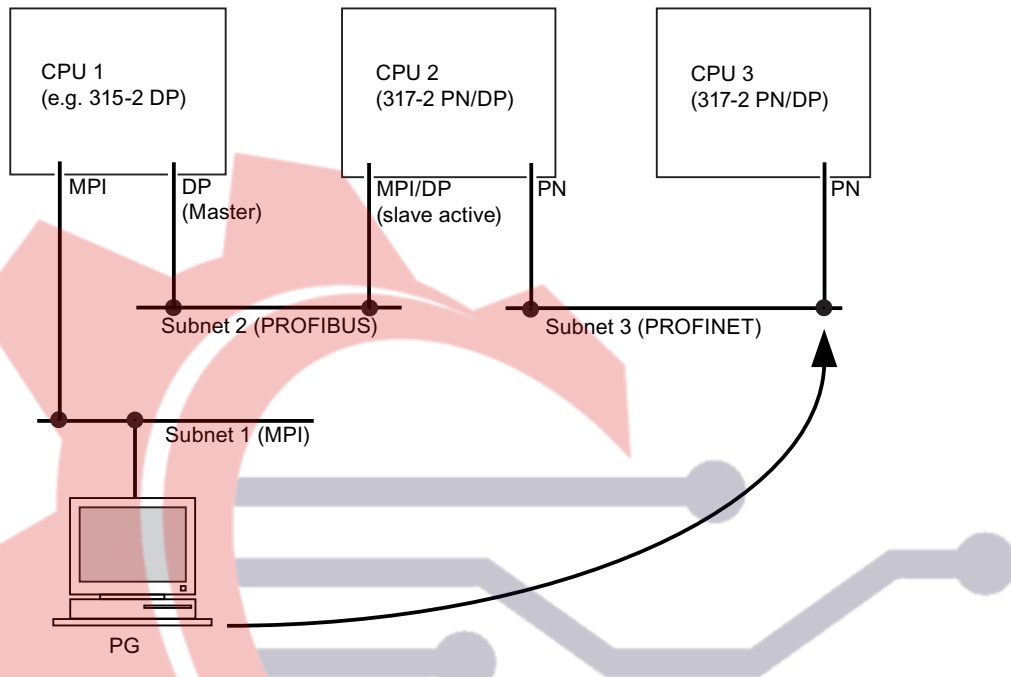

Number of connections for routing

The CPUs with DP interface provide a different number of connections for the routing function:

Table 3- 5 Number of routing connections for DP CPUs

CPU	As of firmware version	Number of connections for routing
31xC, CPU 31x	2.0	Max. 4
317-2 DP	3.3	Interface X1 configured as: <ul style="list-style-type: none"> • MPI: Max. 10 • DP master: Max. 24 • DP slave (active): Max. 14
		Interface X2 configured as: <ul style="list-style-type: none"> • DP master: Max. 24 • DP slave (active): Max. 14
31x-2 PN/DP	2.2	Interface X1 configured as: <ul style="list-style-type: none"> • MPI: Max. 10 • DP master: Max. 24 • DP slave (active): Max. 14
		Interface X2 configured as: <ul style="list-style-type: none"> • PROFINET: Max. 24

CPU	As of firmware version	Number of connections for routing
314C-2 PN/DP	3.3	Interface X1 configured as: <ul style="list-style-type: none"> • MPI: Max. 10 • DP master: Max. 24 • DP slave (active): Max. 14
		Interface X2 configured as: <ul style="list-style-type: none"> • PROFINET: Max. 24
319-3 PN/DP	2.4	Interface X1 configured as: <ul style="list-style-type: none"> • MPI: Max. 10 • DP master: Max. 24 • DP slave (active): Max. 14
		Interface X2 configured as: <ul style="list-style-type: none"> • DP master: Max. 24 • DP slave (active): Max. 14
		Interface X3 configured as: <ul style="list-style-type: none"> • PROFINET: Max. 48

Requirements

- The station modules are "capable of routing" (CPUs or CPs)
- The network configuration does not exceed project limits
- The modules have loaded the configuration data containing the latest "knowledge" of the entire network configuration of the project.

Reason: All modules participating in the gateway must receive the routing information defining the paths to other subnets

- In your network configuration, the PG/PC you want to use to establish a connection via a gateway must be assigned to the network it is physically connected to
- The CPU must set to master mode
- Or if the CPU is configured as slave, the Test, Commissioning, Routing functionality must be enabled for DP slave by activating the checkbox in STEP 7 in the DP interface properties dialog box

Routing: Example of a TeleService application

The figure below shows the example of an application for remote maintenance of an S7 station using a PG. The connection to other subnets is here established via modem connection.

The lower section of the figure shows how easily this can be configured in STEP 7.

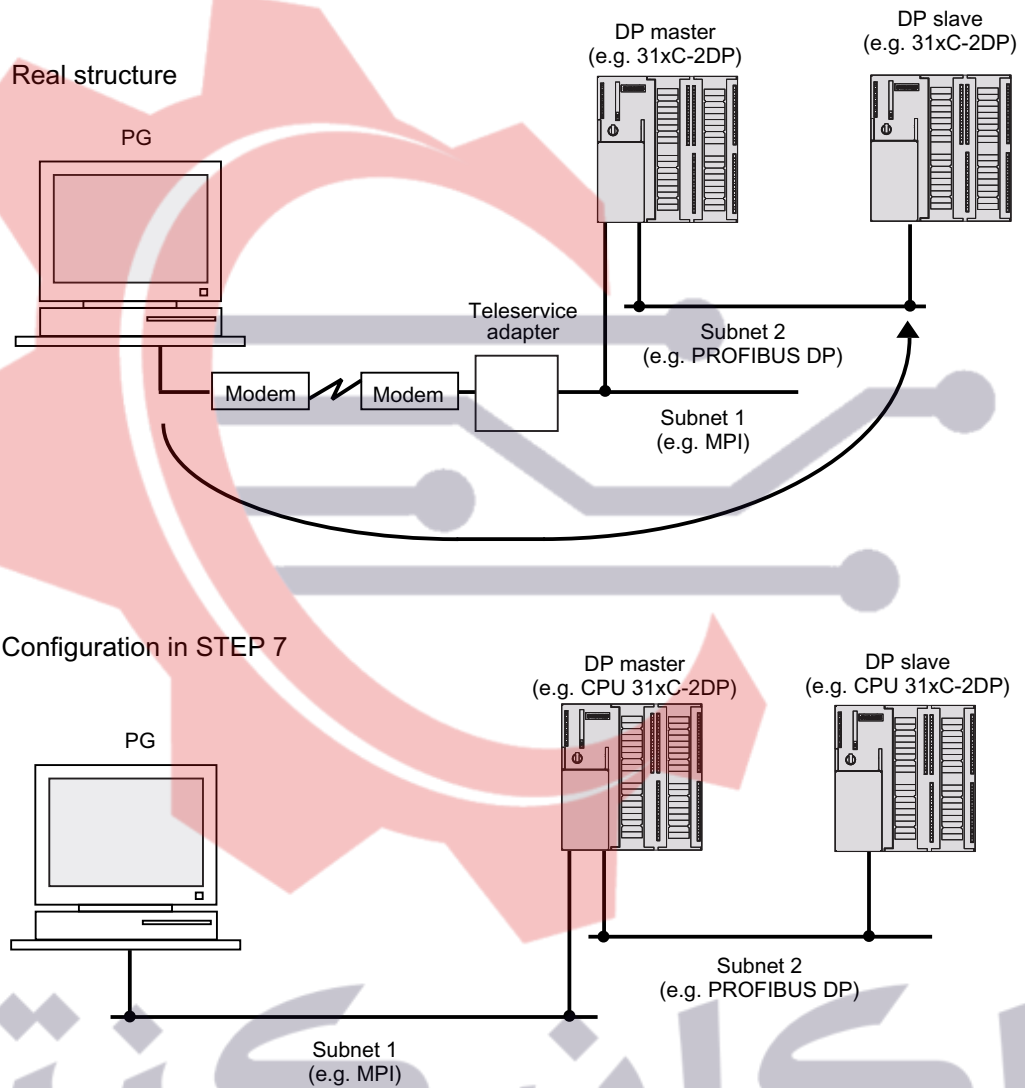

Reference

Additional information

- on configuring in STEP 7 can be found in the *Configuring Hardware and Connections in STEP 7* manual
- on communication is found in the *Communication with SIMATIC* manual
- on the TeleService adapter can be found on the Internet (<http://support.automation.siemens.com/WWW/view/en/20983182>).
- on SFCs can be found in the *instruction list*.
For a detailed description, refer to the *STEP 7 Online Help* or *System and Standard Functions Reference Manual*

3.2.8 Data record routing

Availability

The following CPUs support data record routing:

CPU	As of version
CPU 313C-2 DP	V3.3
CPU 314C-2 DP	V3.3
CPU 314C-2 PN/DP	V3.3
CPU 315-2 DP	V3.0
CPU 315-2 PN/DP	V3.1
CPU 317-2 DP	V3.3
CPU 317-2 PN/DP	V3.1
CPU 319-3 PN/DP	V2.7

ماکان کنترول

Routing and data record routing

Routing is the transfer of data beyond network boundaries. You can send information from a transmitter to a receiver across several networks.

Data record routing is an extension of "normal routing" and is used, for example, by SIMATIC PDM if the programming device is not connected directly to the PROFIBUS DP subnet to which the target device is connected, but, for example, to the PROFINET interface of the CPU. The data sent by means of data record routing include the parameter assignments for the participating field devices (slaves) and device-specific information (e.g. setpoint values, limit values). The structure of the target address for data record routing depends on the data contents, i.e. the slave to which the data is sent.

With the programming device, data record routing can also be used to read a parameter set already existing on the field device, edit it and return it to the field device if the programming device is assigned to a different subnet than that of the target slave.

The field devices themselves do not have to support data record routing, since they do not forward the information received.

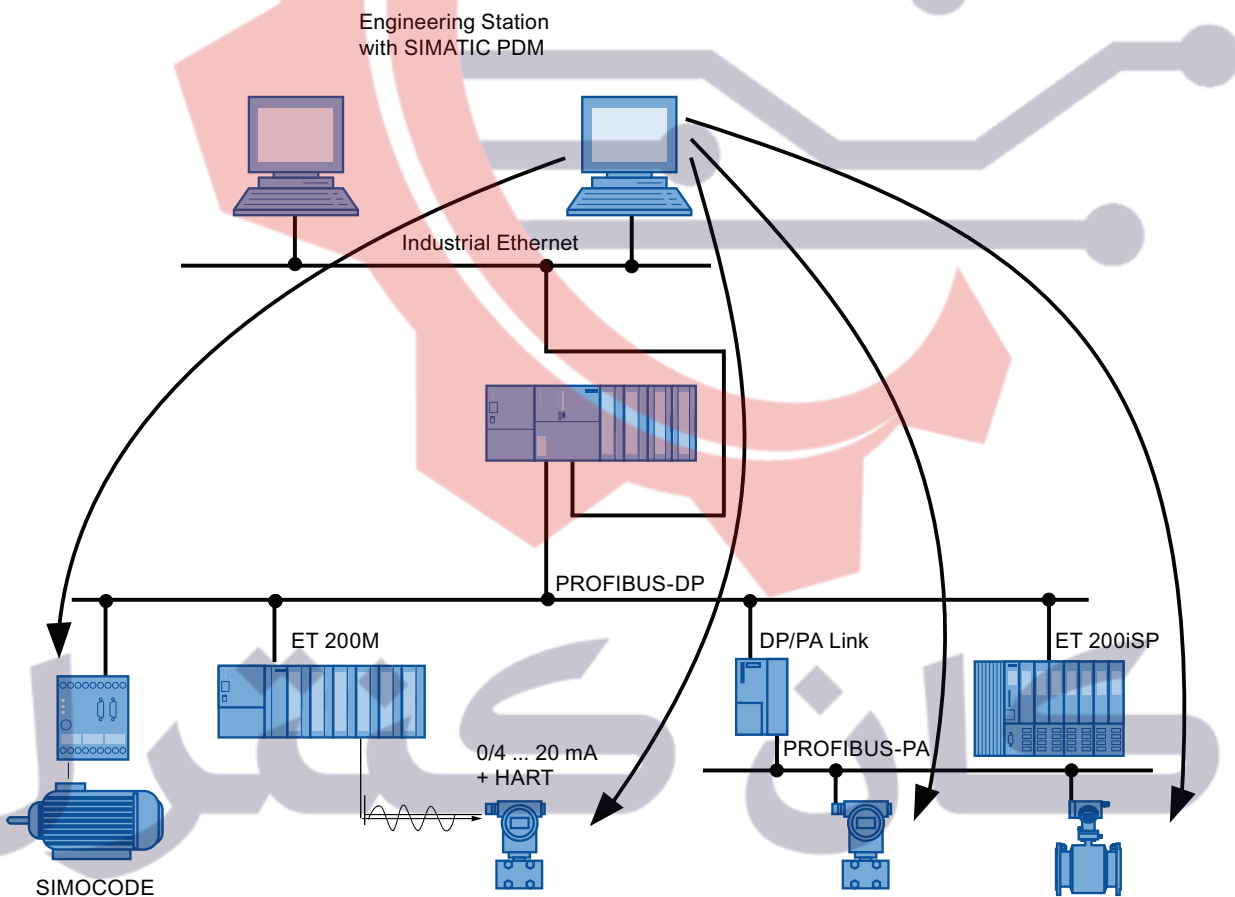

Figure 3-1 Data record routing

See also

You can find additional information on *SIMATIC PDM* in *The Process Device Manager* manual.

3.2.9 Clock synchronization

Introduction

The CPU interfaces support clock synchronization. The CPU can be programmed for operation as time master (with default synchronization intervals) or as time slave.

Default: No clock synchronization

Setting the synchronization mode

In HW Config, in the properties dialog, set the synchronization mode as follows:

- Within the AS (on the central I/O bus): Tab → Diagnostics / Clock (also for MPI on CPUs without DP interface)
- For the MPI/DP or DP interface: Tab → Clock
- For the PROFINET interface: Tab → Clock synchronization

Interfaces

Clock synchronization is supported at the following interfaces:

- MPI interface
You can configure the CPU as time master or time slave.
- DP interface
You can configure the CPU as time master or time slave.
- PROFINET interface
Clock synchronization by means of NTP method and client CPU.
- On the automation system in the central rack
You can configure the CPU as time master or time slave.

Note

The CPU cannot be time slave on more than one of these interfaces.

CPU as time slave

As a time slave, the CPU receives synchronization frames from exactly one time master and accepts this time as its own internal time of the CPU.

CPU as time master

As time master, the CPU broadcasts clock synchronization frames at programmed synchronization intervals to synchronize other stations on the connected subnet.

Requirement: The CPU clock is no longer in default state. The clock must have been set at least once.

Clock synchronization as **time master** starts:

- As soon as you initialize the time by means of SFC 0 "SET_CLK", or programming device function.
- Using another time master, if the CPU is also programmed via MPI/DP or PROFINET interface for operation as time slave.

Note

The real-time clock of the CPU is not set:

- in factory state
 - after reset to factory settings by means of the mode selector switch
 - after firmware updates
-

Example 1

A CPU already set up as time slave on the DP interface must be set up as time master at the MPI interface and/or on the automation system.

Clock synchronization via PROFINET

The CPU can be operated on the PROFINET interface as time-of-day client based on the NTP (Network Time Protocol) procedure.

Default: No clock synchronization based on NTP.

Activate the "Clock synchronization based on NTP" option to synchronize the CPU's clock via PROFINET. This option is available in the "Clock synchronization" properties of the PROFINET interface. You also need to enter the IP addresses of the NTP server and a synchronization interval.

Information on suitable NTP servers and on NTP is available, for example, under the entry ID: 17990844.

Note

The PROFINET interface cannot be operated as time-of-day server, that is, the CPU cannot synchronize any other clocks on PROFINET.

Example 2

A CPU already synchronized over NTP with a time master by means of clock synchronization via PROFINET interface (corresponds to time slave functionality) must be operated as time master at the DP interface and/or MPI interface, or on the automation system.

3.2.10 Point-to-point connection

Properties

A point-to-point connection permits you to exchange data via a serial interface. A point-to-point connection can be used to interconnect programmable controllers, computers or communication-capable third-party systems. Adaptation to the procedure of the communication peer is also possible.

Reference

Additional information

- on SFCs can be found in the *instruction list*.
A detailed description is available in the *STEP 7 Online Help* and in the *Technological Functions* manual
- on communication is found in the *Communication with SIMATIC* manual

3.2.11 Data consistency

Properties

A data area is consistent if it can be read from or written to the operating system as one block. Data exchanged collectively between the stations should belong together and originate from a single processing cycle, that is, be consistent. If the user program contains a programmed communication function, for example, access to shared data with XSEND/ X-RCV, access to that data area can be coordinated by means of the "BUSY" parameter itself.

With PUT/GET functions

For S7 communication functions such as PUT/GET or write/read via OP communication, which do not require a block in the user program of the CPU (in server mode), the extent of the data consistency must be considered already during programming. The PUT/GET functions of S7 communication or reading/writing of variables via OP communication are executed at the CPU's cycle control point. To ensure a defined hardware interrupt response time, the communication variables are copied in blocks of up to 240 bytes consistently to/from the copied user memory in the cycle control point of the operating system. Data consistency is not ensured for larger data areas.

Operations with PUT/GET functions and "prioritized OCM communication"

The data consistency specified will be lost if you configure operations with "prioritized OCM communication" (refer to the "OP communication" (Page 68) chapter). Consequently, data consistency must be ensured by means of the user program.

Consistency is retained for:

- byte, word, Dword access such as L MDx
- SFC 14 "DPRD_DAT"
- SFC 15 "DPWR_DAT"
- SFC 81 "UBLKMOV" (for copying up to 512 bytes of data)

You should also be aware of the fact that, if "prioritized OCM communication" is configured, communication variables in blocks of max. 240 bytes are not copied consistently to/from work memory at the cycle control point. Instead, this data is copied during user program runtime.

Note

Where defined data consistency is required, the length of communication variables in the user program of the CPUs cannot exceed 240 bytes.

3.3 SNMP communication service

Availability

The SNMP V1, MIB-II communication service is available for CPUs with integrated PROFINET interface firmware 2.2 or higher.

Properties

SNMP (Simple Network Management Protocol) is a standard protocol for TCP/IP networks.

Reference

For additional information on the SNMP communication service and diagnostics with SNMP, refer to the *PROFINET system description* and to the *Operating Instructions S7-300 CPU 31xC and CPU 31x, Installation*.

3.4 Open communication via Industrial Ethernet

Requirements

- STEP 7 as of V5.4 + SP4

Functionality

The CPUs with integrated PROFINET interface as of firmware V2.3.0 or V2.4.0 support the functionality of open communication via Industrial Ethernet (in short: *open IE communication*)

The following services are available for open IE communication:

- Connection-oriented protocols
 - TCP according to RFC 793, connection type B#16#01, firmware V2.3.0 and higher
 - TCP according to RFC 793, connection type B#16#11, firmware V2.4.0 and higher
 - ISO-on-TCP according to RFC 1006, firmware V2.4.0 and higher
- Connectionless protocols
 - UDP according to RFC 768, firmware V2.4.0 and higher

Properties of the communication protocols

The following protocol types exist in data communication:

- Connection-oriented protocols:

Prior to data transmission, these protocols establish a (logical) connection to the communication peer and close it again, if necessary, after transmission is completed. Connection-oriented protocols are used when security is especially important in data transmission. Usually several logical connections can be established via a physical cable.

The FBs for open communication via Industrial Ethernet support the following connection-oriented protocols:

- TCP according to RFC 793 (connection types B#16#01 and B#16#11)
- ISO-on-TCP according to RFC 1006 (connection type B#16#12)

- Connectionless protocols:

These protocols operate without a connection. This means that no connections to a remote peer are established and terminated. Connectionless protocols transmit data to the remote peer without any acknowledgement; data transmission is, therefore, not secure.

FBs for open communication via Industrial Ethernet support the following connectionless protocol:

- UDP according to RFC 768 (connection type B#16#13)

How can you use open IE communication?

To allow data to be exchanged with other communication peers, STEP 7 provides the following FBs and UDTs under "Communication Blocks" in the "Standard Library":

- Connection-oriented protocols: TCP, ISO-on-TCP
 - FB 63 "TSEND" for sending data
 - FB 64 "TRCV" for receiving data
 - FB 65 "TCON" for connecting
 - FB 66 "TDISCON" for disconnecting
 - UDT 65 "TCON_PAR" with the data structure for parameterizing the connection
- Connectionless protocol: UDP
 - FB 67 "TUSEND" for sending data
 - FB 68 "TURCV" for receiving data
 - FB 65 "TCON" for establishing the local communication access point
 - FB 66 "TDISCON" for resolving the local communication access point
 - UDT 65 "TCON_PAR" with the data structure for parameterizing the local communication access point
 - UDT 66 "TCON_ADR" with the data structure of the addressing parameters of the remote peer

Data blocks for parameterization

- Data blocks for parameterization of the TCP and ISO-on-TCP connections

To configure the connections with TCP and ISO-on-TCP, you need to create a DB that contains the data structure from UDT 65 "TCON_PAR". This data structure contains all parameters you need to establish the connection. You need such a data structure for each connection, and you can also organize it in a global data storage area.

The CONNECT parameter of the FB 65 "TCON" contains a reference to the address of the corresponding connection description (e.g. P#DB100.DBX0.0 Byte 64).

- Data blocks for the parameterization of the local communication access point with UDP

To assign parameters for the local communication access point, create a DB containing the data structure from the UDT 65 "TCON_PAR". This data structure contains the required parameters you need to establish the connection between the user program and the communication layer of the operating system

The CONNECT parameter of the FB 65 "TCON" contains a reference to the address of the corresponding connection description (e.g. P#DB100.DBX0.0 Byte 64).

Note

Setting up the connection description (UDT 65)

The communication interface has to be entered in the "local_device_id" parameter in UDT65 "TCON_PAR" (e.g. B#16#03: communication via the integrated IE interface of CPU 319-3 PN/DP).

Establishing a connection for communication

- Use with TCP and ISO-on-TCP

Both communication peers call FB 65 "TCON" to establish the connection. In the parameterization you define which communication peer is the activate and which one is the passive communication end point. To determine the number of possible connections, refer to your CPU's technical specifications.

The CPU automatically monitors and maintains the active connection.

If the connection is interrupted, for example due to an open circuit or by the remote communication peer, the active peer tries to reestablish the connection. You do not have to call FB 65 "TCON" again.

An active connection is terminated by calling the FB 66 "TDISCON" or when the CPU is in STOP mode. To reestablish the connection you have to call FB 65 "TCON" again.

- Use with UDP

Both communication peers call FB 65 "TCON" to set up their local communication access point. This establishes a connection between the user program and operating system's communication layer. No connection is established to the remote peer.

The local access point is used to send and receive UDP telegrams.

Disconnecting

- Use with TCP and ISO-on-TCP

FB 66 "TDISCON" disconnects a connection between CPU and communication peer.

- Use with UDP

FB 66 "TDISCON" disconnects the local communication access point, i.e. the connection between user program and communication layer of the operating system is interrupted.

Options for terminating the connection

The following events are available for causing interruptions of communication:

- You program the discontinuation of the connection with the FB 66 "TDISCON".
- The CPU goes from RUN to STOP.
- At Power Off/Power On

Communication diagnostics

In STEP 7 V5.4 SP5 and higher, you can select "Module state → Communication → Open communication over Industrial Ethernet" to read additional information about the configured connections.

Reference

For detailed information on the blocks described above, refer to the *STEP 7 Online Help*.

3.5 S7 connections

3.5.1 S7 connection as communication path

An S7 connection is established when S7 modules communicate with one another. This S7 connection is the communication path.

Note

S7 connections are not required for global data communication, point-to-point connection, communication by way of PROFIBUS DP, PROFINET CBA, PROFINET IO, TCP/IP, ISO on TCP, UDP, SNMP and web server.

Every connection requires S7 connection resources on the CPU for the entire duration of this connection.

Each S7-CPU provides a specific number of S7 connection resources which are used by various communication services (PG/OP communication, S7 communication, or S7 basic communication).

Connection points

An S7 connection between communication-capable modules is established between connection points. The S7 connection always has two connection points: The active and the passive connection point:

- The active connection point is assigned to the module that establishes the S7 connection.
- The passive connection point is assigned to the module that accepts the S7 connection.

Any module that is capable of communication can thus act as an S7 connection point. At the connection point, the established connection always occupies one S7 connection on the relevant module.

Transition point

If you use the routing functionality, the S7 connection between two communication-capable modules is established across a number of subnets. These subnets are interconnected via a gateway. The module that implements this gateway is known as a router. The router is thus the point through which an S7 connection passes.

Any CPU with a DP or PN interface can be the router for an S7 connection. You can establish a specific number of routing connections. This does not limit the quantity framework of S7 connections.

See also

Connection resources for routing (Page 89)

3.5.2 Allocation of S7 connections

There are several ways to allocate S7 connections on a communication-capable module:

- Reservation during configuration
- Allocating connections by means of programming
- Allocating connections during commissioning, testing and diagnostics
- Allocating connections for OCM services

Reservation during configuration

One connection resource each is automatically reserved on the CPU for PG and OP communication. Whenever you need more connection resources (for example, when connecting several OPs), configure this increase in the CPU properties dialog box in STEP 7.

Connections must also be configured (using NetPro) for the use of S7 communication. For this purpose, connection resources which are not allocated to PG/OP or other connections have to be available. The required S7 connections are then permanently allocated for S7 communication when the configuration is downloaded to the CPU.

Allocating connections by means of programming

In S7 basic communication and in open Industrial Ethernet communication with TCP/IP, the user program establishes the connection. The CPU's operating system initiates the connection. S7 basic communication uses the corresponding S7 connections. The open IE communication does not use any S7 connections. However, a maximum number of connections also applies for this type of communication:

- 8 connections with the CPU 314C-2 PN/DP
- 8 connections for CPUs 315-2 PN/DP
- 16 connections for CPUs 317-2 PN/DP
- 32 connections with the CPU 319-3 PN/DP

Allocating connections for commissioning, testing and diagnostics

An online function on the engineering station (PG/PC with STEP 7) allocates S7 connections for PG communication:

- If an S7 connection resource was reserved for PG communication in your CPU hardware configuration, it is assigned to the engineering station, i.e. it only needs to be allocated.
- If all reserved S7 connections for PG communication are allocated, the operating system automatically assigns a free S7 connection resource which has not yet been reserved. If no more connections are available, the engineering station cannot go online to communicate with the CPU.

Allocating connections for OCM services

An online function on the OCM station (OP/TP/... with *WinCC*) is used for allocating S7 connections for the OP communication:

- If an S7 connection resource was reserved for OP communication in your CPU hardware configuration, it is assigned to the OCM station, i.e. it only needs to be allocated.
- If all reserved S7 connection resources for OP communication are allocated, the operating system automatically assigns a free S7 connection resource which has not yet been reserved. If no more connection resources are available, the OCM station cannot go online to communicate with the CPU.

Time sequence for allocation of S7 connections

When you configure your project in STEP 7, parameterization blocks are generated which are read during startup of the modules. Thus the module's operating system reserves or allocates the relevant S7 connections. This means, for instance, that OPs cannot access a reserved S7 connection for PG communication. The CPU's S7 connections which were not reserved can be used as required. These S7 connections are allocated in the order they are requested.

Example

If there is only one free S7 connection left on the CPU, you can connect a PG to the bus. The PG can then communicate with the CPU. The S7 connection is only used, however, when the PG is communicating with the CPU. If you connect an OP to the bus while the PG is not communicating, the OP can establish a connection to the CPU. Since an OP maintains its communication link at all times, in contrast to the PG, you cannot subsequently establish another connection via the PG.

ماکان کنترول

3.5.3 Distribution and availability of S7 connection resources

Distribution of connection resources

Table 3- 6 Distribution of connections

Communication service	Distribution
PG communication OP communication S7 basic communication	In order to avoid allocation of connection resources being dependent only on the chronological sequence in which various communication services log in, connection resources can be reserved for these services. For PG and OP communication respectively, at least one connection resource is reserved by default. In the table below, and in the technical specifications of the CPUs, you can find the configurable S7 connections and the default settings for each CPU. You "redistribute" connection resources by setting the relevant CPU parameters in STEP 7.
S7 communication Other connections (e.g. via CP 343-1 with data lengths of > 240 bytes)	Available connection resources which are not specially reserved for a service (PG/OP communication, S7 basic communication) are allocated for this.
Routing of PG functions (only for CPUs with DP/PN interface)	The CPUs provide a certain number of connections for routing. These connections are available in addition to the connection resources. The subsection below shows the number of connection resources.
Global data communication Point-to-point connection PROFIBUS DP PROFINET CBA PROFINET IO Web server	These communication services require no S7 connection resources.
Open communication by means of TCP/IP	This communication service requires no S7 connection resources.
Open communication by means of ISO-on-TCP	A CPU-specific number of internal resources is available for TCP/IP, ISO on TCP and UDP communication, or for local access points (UDP), independent of the S7-Connections (refer to Technical specifications of CPU 31x (Page 301) chapter and Technical Specifications of CPU 31x (Page 213) chapter).
Open communication by means of UDP	
SNMP	This communication service requires no S7 connection resources.

Availability of connection resources

Table 3- 7 Availability of connection resources

CPU	Total number of connection resources	Reserved for			Free S7 connections
		PG communication	OP communication	S7 basic communication	
312 312C	6	1 to 5, default 1	1 to 5, default 1	0 to 2, default 0	All non-reserved S7 connections are displayed as free connections.
313C 313C-2 PtP 313C-2 DP	8	1 to 7, default 1	1 to 7, default 1	0 to 4, default 0	
314 314C-2 PtP 314C-2 DP 314C-2 PN/DP	12	1 to 11, default 1	1 to 11, default 1	0 to 8, default 0	
315-2 DP 315-2 PN/DP	16	1 to 15, default 1	1 to 15, default 1	0 to 12, default 0	
317-2 DP 317-2 PN/DP	32	1 to 31, default 1	1 to 31, default 1	0 to 30, default 0	
319-3 PN/DP	32	1 to 31, default 1	1 to 31, default 1	0 to 30, default 0	

Note

When using a CPU 314C-2 PN/DP, you can configure up to 10 connection resources for S7 communication in NetPro: When using the CPU 315-2 PN/DP, you can configure up to 14 connection resources for S7 communication in NetPro: These connections are then no longer available as free connections.

For CPU 317-2 PN/DP and CPU 319-3 PN/DP, you can configure up to 16 connection resources for S7 communication in NetPro.

ماکان کنترول

3.5.4 Connection resources for routing

Number of connection resources for routing

CPU with DP interface provide a different number of connection resources for the routing function:

Table 3- 8 Number of connection resources for routing (for DP/PN CPUs)

CPU	As of firmware version	Number of connections for routing
31xC, CPU 31x	2.0	Max. 4
317-2 DP	3.3	Interface X1 configured as: <ul style="list-style-type: none"> • MPI: Max. 10 • DP master: Max. 24 • DP slave (active): Max. 14
		Interface X2 configured as: <ul style="list-style-type: none"> • DP master: Max. 24 • DP slave (active): Max. 14
31x-2 PN/DP	2.2	Interface X1 configured as: <ul style="list-style-type: none"> • MPI: Max. 10 • DP master: Max. 24 • DP slave (active): Max. 14
		Interface X2 configured as: <ul style="list-style-type: none"> • PROFINET: Max. 24
314C-2 PN/DP	3.3	Interface X1 configured as: <ul style="list-style-type: none"> • MPI: Max. 10 • DP master: Max. 24 • DP slave (active): Max. 14
		Interface X2 configured as: <ul style="list-style-type: none"> • PROFINET: Max. 24
319-3 PN/DP	2.4	Interface X1 configured as: <ul style="list-style-type: none"> • MPI: Max. 10 • DP master: Max. 24 • DP slave (active): Max. 14
		Interface X2 configured as: <ul style="list-style-type: none"> • DP master: Max. 24 • DP slave (active): Max. 14
		Interface X3 configured as: <ul style="list-style-type: none"> • PROFINET: Max. 48

Example of a CPU 314C-2 DP

The CPU 314C-2 DP provides 12 connection resources (see Table 3-10):

- Reserve 2 connection resources for PG communication
- Reserve 3 connection resources for OP communication
- Reserve 1 connection resource for S7 basic communication

This leaves 6 connection resources available for other communication services, e.g. S7 communication, OP communication, etc.

In addition, 4 routing connections via the CPU are possible.

Example for a CPU 317-2 PN/DP / CPU 319-3 PN/DP

The CPU 317-2 PN/DP and CPU 319-3 PN/DP provide you with 32 connection resources (refer to Table 3-10):

- Reserve 4 connection resources for PG communication
- Reserve 6 connection resources for OP communication
- Reserve 2 connection resources for S7 basic communication
- In NetPro you configure 8 S7 connection resources for S7 communication via the integrated PROFINET interface

This leaves 12 S7 connections available for arbitrary communication services such as S7 communication, OP communication, etc.

However, only a maximum of 16 connection resources for S7 communication at the integrated PN interface can be configured in NetPro.

In addition, there are another 24 routing connections available for the CPU 317-2 PN/DP, and another 48 routing connections for the CPU 319-3 PN/DP, which do not affect the above described S7 connection resources.

However, take the interface-specific maximum numbers into account (refer to Table 3-11).

ماکان کنترول

3.6 DPV1

New automation and process engineering tasks require the range of functions performed by the existing DP protocol to be extended. In addition to cyclical communication functions, acyclical access to non-S7 field devices is another important requirement of our customers and was implemented in the standard EN 50170. In the past, acyclical access was only possible to S7 slaves. The distributed I/O standard EN 50170 has been further developed. All changes concerning new DPV1 functions are included in IEC 61158/EN 50170, volume 2, PROFIBUS.

Definition DPV1

The term DPV1 is defined as a functional extension of the acyclical services (to include new interrupts, for example) provided by the DP protocol.

Availability

All CPUs with DP interface(s) and serving as DP masters feature the enhanced DPV1 functionality.

Note

If you want to use the CPU as an intelligent DP slave, it does not have DPV1 functionality.

Requirement for using the DPV1 functionality with DP slaves

For DPV1 slaves from other vendors, you will need a GSD file conforming to EN 50170, revision 3 or later.

Extended functions of DPV1

- Use of any DPV1 slaves from third-party manufacturers (in addition to the existing DPV0 and S7 slaves, of course).
- Selective handling of DPV1-specific interrupt events by new interrupt blocks.
- New standard-compliant SFBs for reading/writing data records (which, however, can also be used for centralized modules).
- User-friendly SFB for readout of diagnostics.

Interrupt blocks with DPV1 functionality

Table 3- 9 Interrupt blocks with DPV1 functionality

OB	Functionality
OB 40	Hardware interrupt
OB 55	Status interrupt
OB 56	Update interrupt
OB 57	Vendor-specific interrupt
OB 82	Diagnostic interrupt

Note

You can now also use the organization blocks OB40 and OB82 for DPV1 interrupts.

System blocks with DPV1 functionality

Table 3- 10 System function blocks with DPV1 functionality

SFB	Functionality
SFB 52	Read data record from DP slave/IO device or central module
SFB 53	Write data record to DP slave/IO device or central module
SFB 54	Read additional alarm information from a DP slave/IO device or a centralized module in the relevant OB
SFB 75	Send alarm to the DP master

Note

You can also use SFB 52 to SFB 54 for centralized I/O modules. SFB 52 to SFB 54 can also be used for PROFINET IO.

Reference

For additional information on the blocks above, refer to the Reference Manual *System Software for S7-300/400: System and Standard Software*, or directly to the *STEP 7 Online Help*.

See also

PROFIBUS DP (Page 58)

3.7 Web server

Introduction

The web server allows you to monitor the CPU via the Internet or the intranet of your company. This permits evaluation and diagnostics over long distances. Messages and status information are visualized on HTML pages.

Web browser

You need a web browser to access the HTML pages of the CPU.

The following web browsers are suitable for communication with the CPU:

- Internet Explorer (as of V6.0)
- Mozilla Firefox (as of V1.5)
- Opera (as of V9.0)
- Netscape Navigator (as of V8.1)

Reading information via the web server

The following table lists the information that you can read from the CPU and the CPU firmware version that supports this function:

	CPU 314, as of firmware...	CPU 315, as of firmware...	CPU 317, as of firmware...	CPU 319, as of firmware...
Start page with general CPU information	V3.3	V2.5	V2.5	V2.5
Identification information	V3.3	V2.5	V2.5	V2.5
Content of the diagnostic buffer	V3.3	V2.5	V2.5	V2.5
Module information	V3.3	V3.1	V3.1	V2.7
Messages (without acknowledgment option)	V3.3	V2.5	V2.5	V2.5
Information about communication	V3.3	V2.5	V2.5	V2.5
• Important interface parameters	V3.3	V2.5	V2.5	V2.5
• Port statistics	V3.3	V2.5	V2.5	V2.5
• Display of the communication connections for open communication (OUC)	V3.3	V3.2.1	V3.2.1	V3.2.1
• Display of the communication resources	V3.3	V3.2.1	V3.2.1	V3.2.1
Topology	V3.3	V3.1	V3.1	V2.7
• Display of the actual topology	V3.3	V3.1	V3.1	V2.8
• Display of the target topology specified in configuration data	V3.3	V3.2.1	V3.2.1	V3.2.1
Status of the variables	V3.3	V2.5	V2.5	V2.5
Variable tables	V3.3	V2.5	V2.5	V2.5
User pages (CPU31x PN/DP ≥ V3.2.1, and STEP 7 V5.5)	V3.3	V3.2.1	V3.2.1	V3.2.1

On the following pages you will find detailed information on the HTML pages and explanations.

Web access to the CPU via PG/PC

Proceed as follows to access the web server:

1. Connect the client (PG/PC) to the CPU via the PROFINET interface.
2. Open the web browser.

Enter the IP address of the CPU in the "Address" field of the web browser in the format `http://a.b.c.d` or `https://a.b.c.d` (example: `http://192.168.3.141`).

The CPU start page opens. From the start page you can navigate to further information.

Note

Up to 5 http-/https connections are supported.

Web access to the CPU via HMI devices and PDA

The web server also supports the Windows Terminal Service. In addition to PGs and PCs, this functionality also supports the integration of thin client solutions for mobile devices (e.g. PDA, MOBIC T8) and of rugged local stations (e.g. SIMATIC MP370 with ThinClient/MP option) under Windows CE.

Proceed as follows to access the web server:

1. Connect the client (HMI device, PDA) with the CPU via the PROFINET interface.
2. Open the web browser.

Enter the IP address of the CPU in the "Address" field of the web browser in the format `http://a.b.c.d/basic`, or `https://a.b.c.d/basic` (example: `http://192.168.3.141/basic`).

The CPU start page opens. From the start page you can navigate to further information.

HMI devices operating with the Windows CE operating system V 5.x or earlier process CPU information in a browser specially developed for Windows CE. The information appears in a simplified format in this browser. The following figures show the detailed format in each case.

Note

Using SIMATIC Micro Memory Card together with Web server

The configuration data for the Web server is stored on the SIMATIC Micro Memory Card. We therefore recommend that you use a SIMATIC Micro Memory Card with at least 512 KB.

You can also use the web server without SIMATIC Micro Memory Card. The CPU must have been assigned an IP address to permit operation.

- The content of the diagnostic buffer is displayed in hexadecimal code.
 - Start page, identification and communication information, and variable status are displayed in plain text.
 - Following displays remain empty:
 - Module information
 - Messages
 - Topology
 - Variable tables
 - User pages
 - Automatic update of the pages is set by default until configured otherwise.
-

Security

The Web server provides the following security functions:

- Access via secure https transmission protocol
- User authorizations you can configure by means of user list

Safe-guard your CPUs that provide online access to the Web against intrusion by setting up a firewall.

3.7.1 Language settings

Introduction

The Web server provides messages and diagnostic information in the following languages:

- German (Germany)
- English (USA)
- French (France)
- Italian (Italy)
- Spanish (International Sort)
- Chinese (Simplified)
- Japanese

The two Asian languages can be combined as follows:

- Chinese with English
- Japanese with English

Requirements for the availability of the Asian languages

The following requirements have to be fulfilled for the Asian languages Chinese and Japanese:

- The corresponding language package is installed on the display device (e.g. PC).
- For CPU programming, STEP 7 for Asian languages (STEP 7, V5.5 or higher) is installed on the programming device.

Note

Asian languages are not supported for SIMATIC HMI devices with Windows CE operating system.

Requirements for multilingual output of text

The following two language settings must be made in STEP 7 to permit that the web server displays the different languages correctly:

- Set the regional language for the display devices in SIMATIC Manager
- Set the regional web language in the properties dialog of the CPU. For more information, refer to chapter: Settings in HW Config, "Web" tab (Page 97)

Set the regional language for the display devices in SIMATIC Manager

Select languages for display devices in SIMATIC Manager:
Options > Language for display devices

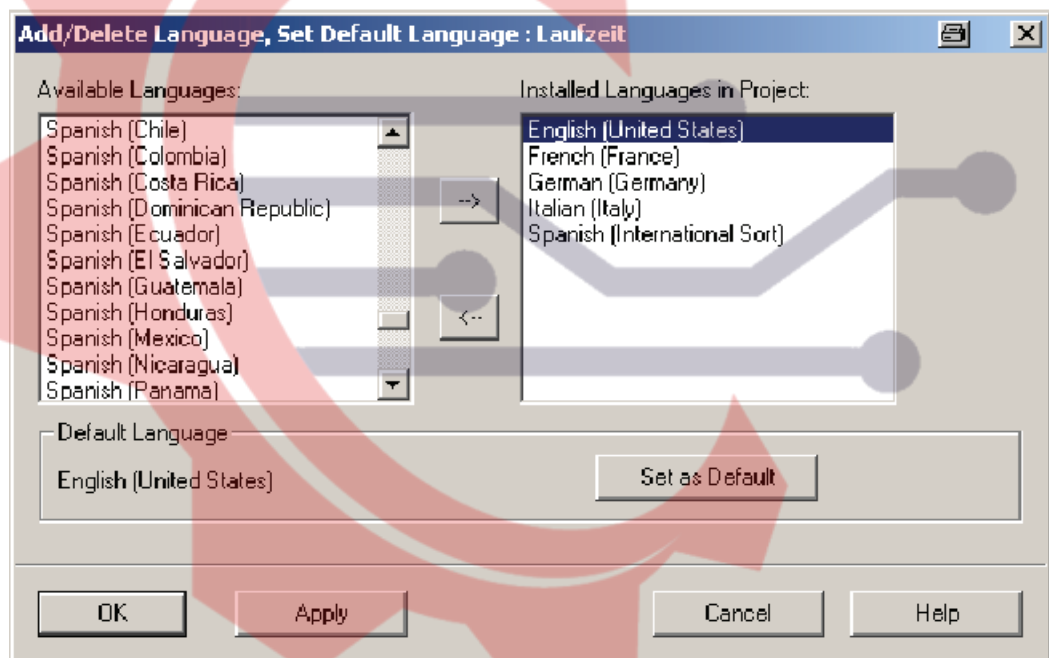

Figure 3-2 Example of the selection of a language for display devices

ماكان كنترول

3.7.2 Settings in HW Config, "Web" tab

Requirements

You have opened the properties dialog of the CPU in HW Config.

Carry out the following settings in the "Web" tab to use the full functionality of the web server:

- Enable the web server
- Set the regional web language
- Adding entries to the user list
- HTTPS access activation
- Activating automatic updates
- Selecting the display classes of the messages

In order to enjoy the full functionality of the module information reports, message system, and topology of the project, you should also generate and load the "Report system errors" function.

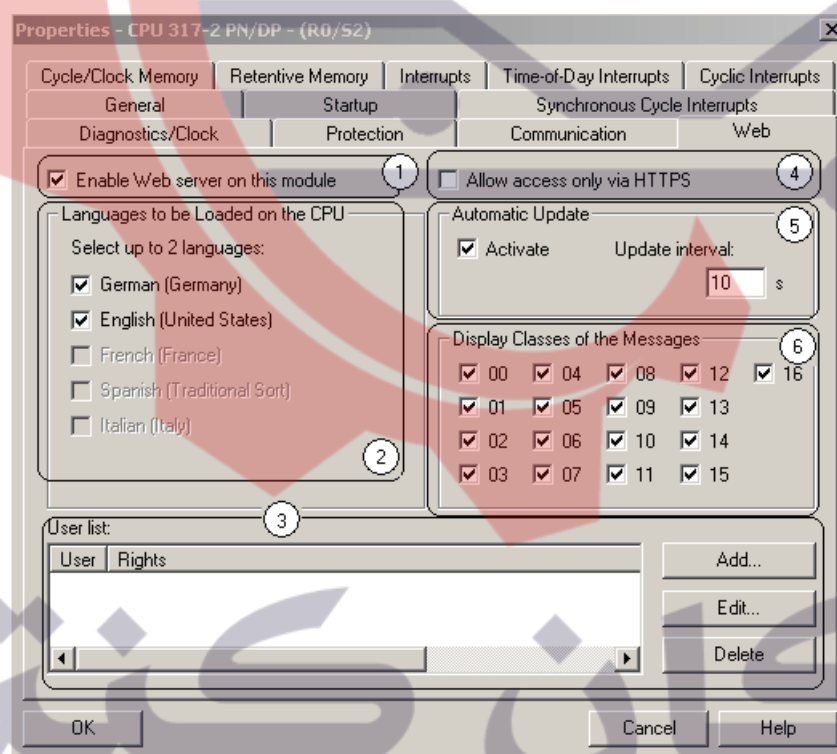

① Activating the web server

The web server is deactivated in the basic configuration in HW Config. You activate the web server in HW Config.

In the property view of the CPU:

- Activate the "Enable Web server on this module" checkbox

② Setting the regional web language

Select up to two web languages from the languages installed for the display devices.

In the property view of the CPU:

- Activate the "Enable Web server on this module" checkbox
- Select up to two web languages.

Note

The program displays messages and diagnostics information in hexadecimal code if you enable the web server without selecting a language.

③ User list

The user list provides the following options:

- Creating users
- Specifying execution rights
- Assigning passwords.

This assignment restricts user access exclusively to the options linked permanently to the execution rights.

- If no users were configured in HW Config, read-only access is granted to all Web pages.
- If users are configured, users who are not logged on can access the Intro and Start pages only.
- Configured users who are logged on are allowed to access the Web pages in accordance with their access rights.
- If you configured a specific user with "everybody" login, other users who are not logged on **do not have to enter a password** in order to access pages released for the "everybody" group.

For example, if the user group "everybody" is granted access rights to "Read variables", the "Variable table" Web page is always displayed in the main menu bar without a password having been entered.

You can create a maximum of 20 users and "everybody" users.

④ Access via HTTPS only

https is used to encrypt communication between the browser and Web server. For error-free https access to the CPU, the following conditions must be met:

- The current time is set on the CPU
- The IP address of the CPU is set (example: https://192.168.3.141)
- A valid certificate is installed

If no certificate is installed, a warning recommends not to use the page. To view this page, you must explicitly "Add an exception".

A valid certificate (Certification Authority) is available for download from the "Intro" Web page, "Download certificate". Instructions for installing the certificate are available in the help system of your Web browser.

An encrypted connection is identified by means of a lock icon in the status bar of the Web page.

⑤ Activating automatic updates

The following web pages can be updated automatically:

- Start page
- Diagnostic buffer
- Module information
- Messages
- Information about communication
- Topology
- Status of the variables
- Variable table

To enable automatic updates, proceed as follows:

- Set the "Activate" check box at "Automatic update" in the properties dialog ("Web" tab) of the CPU.
- Enter the update interval

Note

Update time

The update interval set in HW Config is the shortest update time. Larger data volumes or multiple http/https connections increase the update time.

⑥ Display classes of the messages

All display classes of the messages are activated in the basic configuration in HW Config. The messages for the selected display classes are displayed later on the "Messages" web page. Messages for display classes that are not selected are shown as hexadecimal code and not as plain text.

How to configure the message classes:

- For "Report system error" in HW Config under **Options > Report System Error**
- For block-specific messages in STEP 7

Information about configuring message texts and classes can be found in STEP 7.

Note

Reducing the memory requirements of the Web SDBs

You can reduce the memory requirements of the Web SDBs by selecting only those display classes of the messages that are to be filled in the Web SDB.

3.7.3 Updating and storing information

Update status of the screen content

Automatic updating is deactivated in the basic configuration in HW Config. This means that the screen of the Web server outputs static information.

Refresh the Web pages manually using the <F5> function key, or the following icon:



Update status of printouts

Data output to the printer always indicates the latest CPU information. Therefore, it is possible that the printed information is more up to date than the contents on your screen.

To open a print preview of the Web page, click the following icon:



Filter settings have no effect on the printout, The printout of the "Messages" and "Module information" web pages always shows the complete content of the pages.

Disabling automatic updates for an individual web page

In order to temporarily disable automatic updates for a Web page, select the following icon:



Re-enable automatic updates again using the <F5> function key, or the following icon:



Saving messages and entries of the diagnostic buffer

You can save messages and diagnostics buffer entries to a csv file. Use the following icon to save the data:



A dialog opens in which you can specify the file name and target directory.

To prevent incorrect display of the data in Excel, do not open the csv file with double-click. Import the file in Excel by selecting the "Data" and "Import external data" menu commands.

3.7.4 Web pages

3.7.4.1 Start page with general CPU information

Connecting to the web server

To open a connection to the Web server, enter the IP address of the configured CPU in the address bar of the Web browser, e.g. <http://192.168.1.158> , or <https://192.168.1.158>. The connection is set up and the "Intro" page opens.

In this section, we'll show you some examples of the layout of different Web pages and explain their functions.

Intro

The screenshot below shows the first page (Intro) called by the Web server.



Figure 3-3 Intro

Click the ENTER link to go to the web server pages.

Note

Skipping the Intro Web page

Select the "Skip Intro" check box in order to skip the Intro. As of now, the Web server will take you directly to its start page. To display the intro at the start of the web server again, click the "Intro" link on the start page.

Start page

Before the log in, the Start page offers information as shown in the figure below. The CPU image with LEDs returns the actual CPU status at the time of data request.

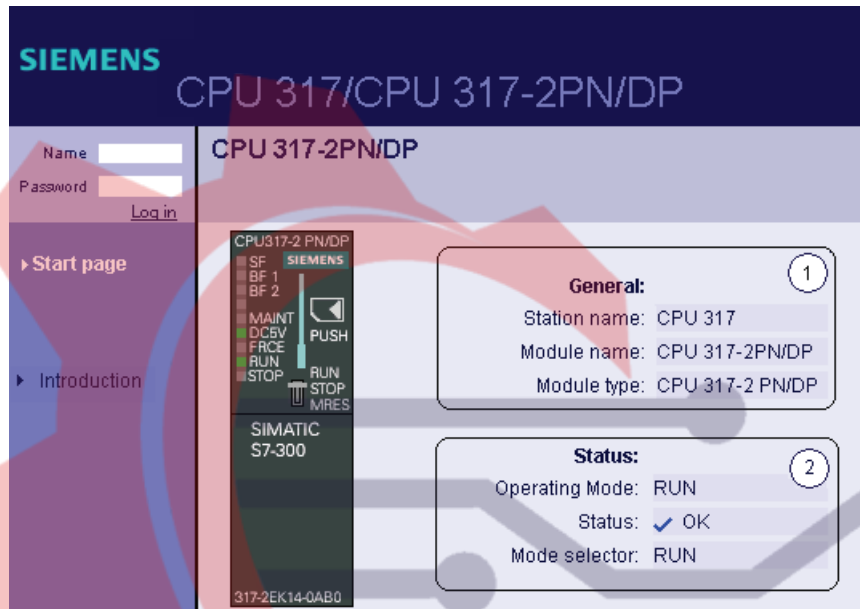

Figure 3-4 Start page before log in

Log in

You must be logged in in order to use the full functionality of the Web pages. Log in with a user name and password specified in the WEB configuration in HW Config. You now have corresponding authorizations to access the Web pages released for this user. (For more information, refer to chapter: Settings in HW Config, "Web" tab (Page 97)

① "General"

"General" contains information about the CPU with whose web server you are currently connected.

② "Status"

"Status" contains information about the CPU at the moment of the query.

Reference

Information on http/https connections, see chapter: Settings in HW Config, "Web" tab (Page 97)

3.7.4.2 Identification

Characteristics

The CPU parameters are available on the "Identification" Web page.

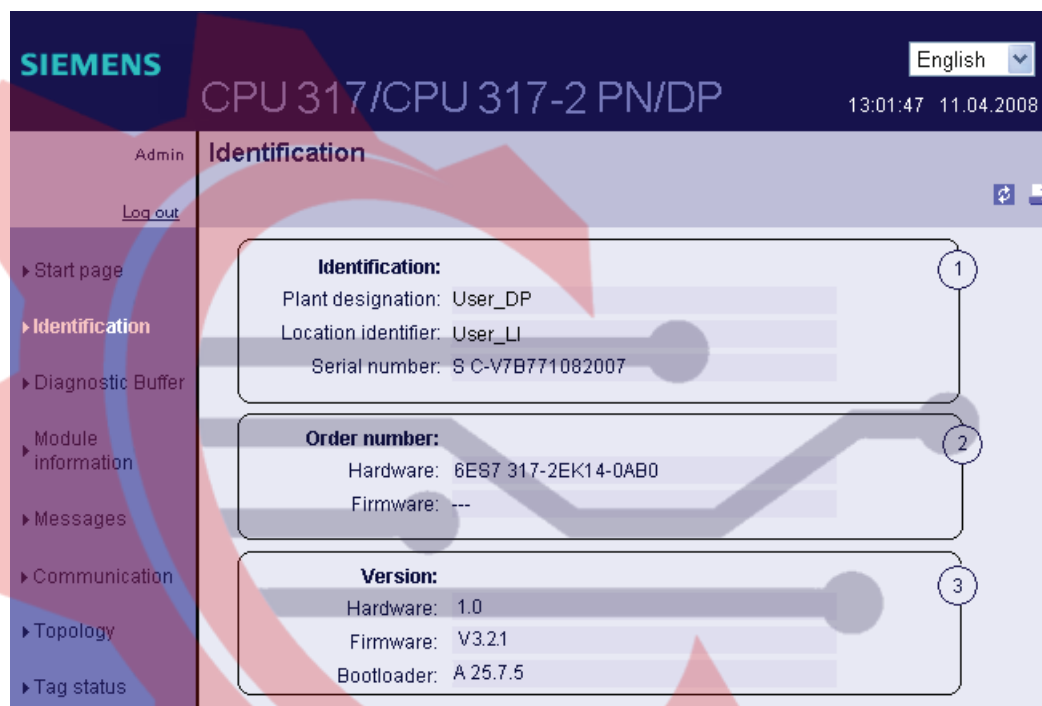

Figure 3-5 Identification

① "Identification"

The "Identification" info box contains the plant and location designation and the serial number. Plant and location designations can be configured in HW Config in the properties dialog box of the CPU, "General" tab.

② "Order number"

The "Order number" info box contains the order numbers for the hardware and firmware (if applicable).

③ "Version"

You can find the hardware, firmware and bootloader versions in the "Version" field.

3.7.4.3 Diagnostic buffer

Diagnostic buffer

The browser displays the content of the diagnostic buffer on the "Diagnostic buffer" web page.

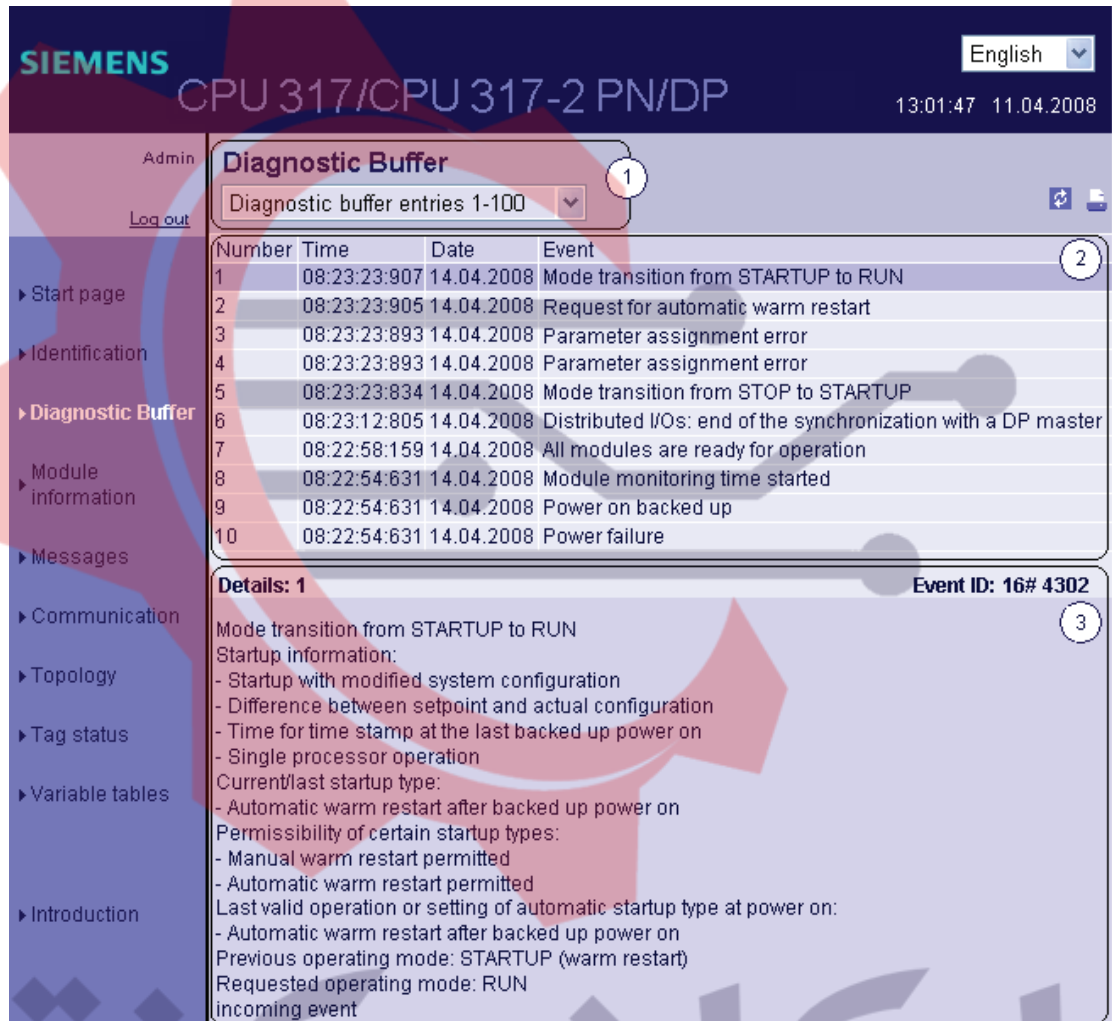

Figure 3-6 Diagnostic buffer

Requirements

The web server is activated, languages are set, and the project is compiled and downloaded in STEP 7.

① "Diagnostic buffer entries 1-100"

The diagnostic buffer can save up to 500 messages. Select an interval for the entries from the drop-down list box. Each interval comprises 100 entries.

In HW Config (CPU properties), you can set the parameters for PROFINET CPUs \geq V2.8 to display from 10 to 499 diagnostic buffer entries in RUN. In RUN, 10 entries are set as default.

② "Event"

The "Event" info box contains the diagnostic interrupts with date and time.

③ "Details"

This field outputs detailed information about a selected event.

Select the corresponding event from the ② "Event" info field.

Configuration

Configuration procedure:

1. Open the "Object properties" dialog box from the context menu of the corresponding CPU.
2. Select the "Web" tab, and then activate the "Enable Web server on this module" checkbox.
3. Select up to two languages for displaying plain text messages.
4. Save and compile the project and download the configuration to the CPU.

Special features when changing languages

You can change the language, e.g. from German to English, in the upper right corner. If you select a language you have not configured, the program returns a hexadecimal code instead of plain text information.

ماکان کنترول

3.7.4.4 Module information

Requirements

- You have carried out the following settings in HW Config:
 - Web server activated
 - Language settings carried out
 - "Report system error" generated and activated
- You have compiled the project using STEP 7 HW Config, loaded the SDB container and the user program (in particular the user program blocks generated by "Report system error")
- The CPU is in RUN mode

Note

"Report system error"

- **Duration of the display:** Depending on the plant extension level, the "Report system error" display requires some time to create the initial evaluation of the state of all the configured I/O modules and I/O systems. During this time there is no concrete display of the status on the "Module information" web page. A "?" is displayed in the "Status" column.
 - **Dynamic response:** "Report system error" has to be called up cyclically at least every 100 ms.
Calling up can take place in OB 1, or if the cycle time amounts to more than 100 ms, in the watchdog interrupt OB 3x (≤ 100 ms) and in the restart OB 100.
 - **Diagnostics support:** In the "Report system error" dialog box, the "Diagnostic status DB" check box must be selected in the "Diagnostics support" tab and a DB number entered. This check box is normally selected as default with configured Web servers. During the migration of old project, it may however be necessary to select this check box.
-

Module information

The state of a station is indicated by means of symbols and comments on the "Module information" web page.

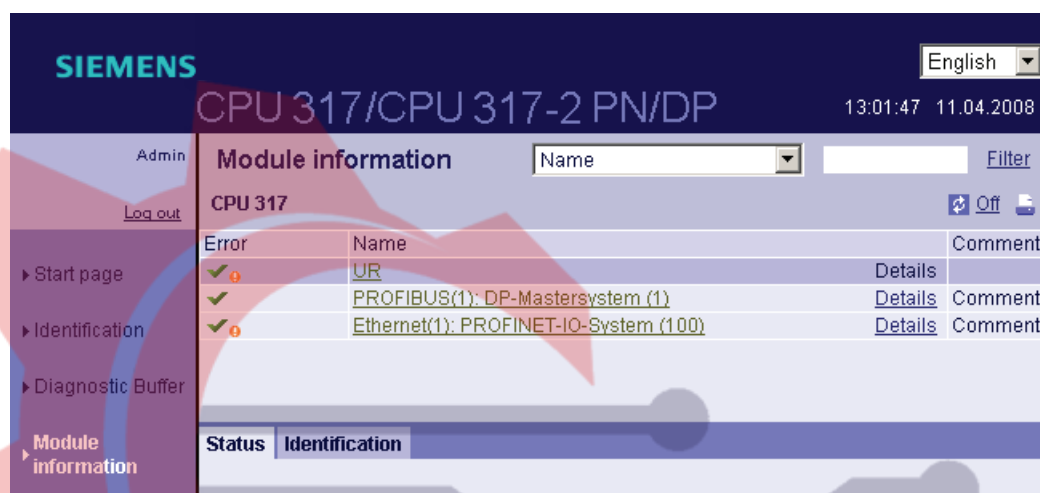





Figure 3-7 Module information - station

Meaning of the symbols in the "Symbol" column

Symbol	Color	Meaning
	green	Component is OK
	gray	Disabled PROFIBUS slaves or PROFINET devices Support conditions: <ul style="list-style-type: none"> • CPU31x PN/DP ≥ V3.2.1 and STEP 7 V5.5 + possible required HSP for the CPU • Enabling/disabling the PROFIBUS slaves and PROFINET IO devices using SFC12 mode 3/4 • In the "Report system errors" dialog, "Diagnostics support" tab, "Status enabled/disabled" area, the check mark must be set in the "Request device status enabled/disabled" check box after CPU startup and optionally in the "Output message on status transition" check box.
	black	Component cannot be accessed/Status cannot be determined <ul style="list-style-type: none"> • For example, "Status cannot be determined" is always displayed while the CPU is in STOP mode, or during startup evaluation of "Report system error" for all the configured I/O modules and I/O systems after a CPU restart. • However, this status can also be displayed temporarily during operation if a diagnostic interrupt burst occurs at all modules. • It is not possible to determine the status of modules on a subsystem that is connected to a CP.
	green	Maintenance required

Symbol	Color	Meaning
	yellow	Maintenance requested
	red	Error - component failed or faulty
	-	Error in a lower module level

Navigation to further module levels

The status of individual components/modules/submodules is displayed when you navigate to the further module levels:

- To higher module levels using the links in the display of the module levels ②
- To lower module levels using the links in the "Name" column

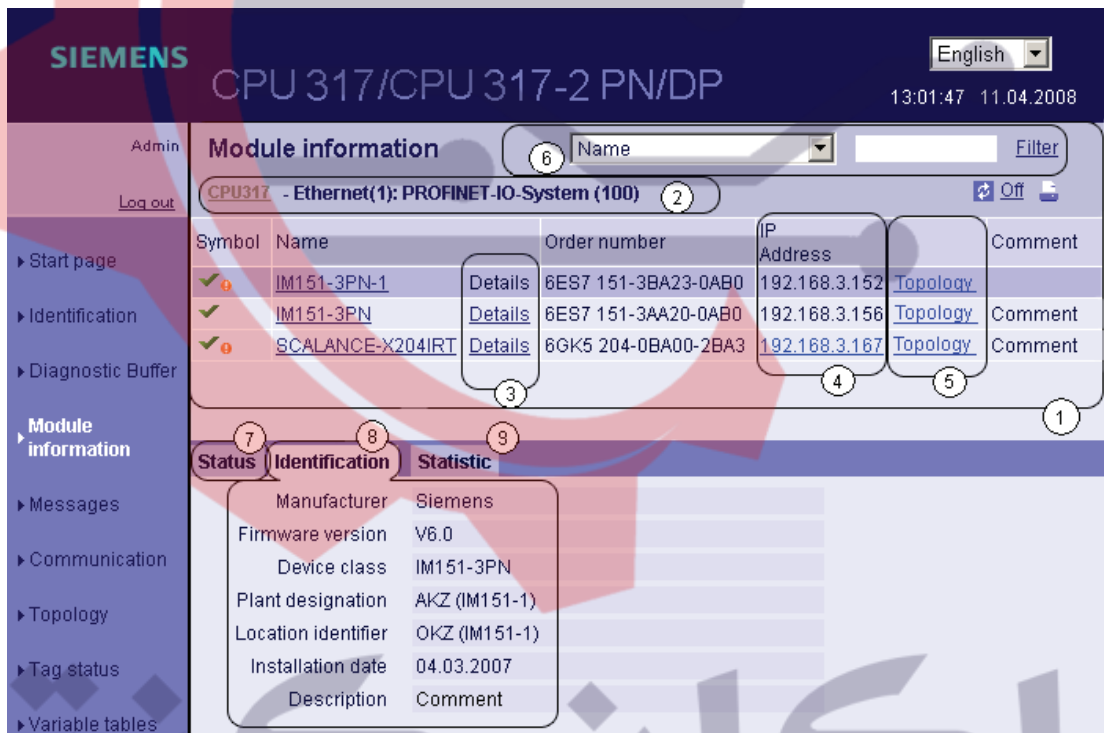

The screenshot shows the Siemens SIMATIC Manager web interface for a CPU 317. The main content area displays "Module information" for the "CPU317 - Ethernet(1): PROFINET-IO-System (100)". A table lists modules with columns for Symbol, Name, Order number, IP Address, and Comment. A detailed view of a selected module (IM151-3PN) is shown below the table, with tabs for Status, Identification, and Statistic. Numbered callouts 1-9 point to various UI elements: 1 (Module information tab), 2 (Module selection dropdown), 3 (Details link), 4 (IP Address column), 5 (Topology link), 6 (Filter dropdown), 7 (Status tab), 8 (Identification tab), and 9 (Statistic tab).

Symbol	Name	Order number	IP Address	Comment
IM151-3PN-1	Details	6ES7 151-3BA23-0AB0	192.168.3.152	Topology
IM151-3PN	Details	6ES7 151-3AA20-0AB0	192.168.3.156	Topology
SCALANCE-X204IRT	Details	6GK5 204-0BA00-2BA3	192.168.3.167	Topology

Manufacturer	Siemens
Firmware version	V6.0
Device class	IM151-3PN
Plant designation	AKZ (IM151-1)
Location identifier	OKZ (IM151-1)
Installation date	04.03.2007
Description	Comment

Figure 3-8 Module information - module

① "Module information"

Depending on the selected level, the table contains information about the rack, the DP master system, the PNIO master system, about the nodes, the individual modules, or also the modules or submodules of the station.

② "Display of the module levels"

The links are used to access the "Module information" of the higher module levels.

③ "Details"

Further information about the selected module is provided in the "Status" and "Identification" tabs via the "Details" link.

④ "IP address"

If a link is available, you can use it to access this Web server of the configured device you selected.

⑤ "Topology"

The two web pages, "Topology" and "Module information", are linked. A click on "Topology" of the selected module automatically takes you to this module in the graphic view of the target topology on the "Topology" Web page. The module appears in the visible area of the "Topology" web page and the device head of the selected module flashes for a few seconds.

⑥ "Filter"

You can search in the table by selecting specific criteria:

1. Select a parameter from the drop-down list box.
2. If applicable, enter the value of the selected parameter.
3. Click "Filter".

The filter criteria are also retained when you update a page.

To deactivate the filter settings, click "Filter" again.

⑦ "Status" tab

The tab contains information about the status of the selected module when a fault or message exists.

⑧ "Identification" tab

The tab contains data on the identification of the selected module.

Note

This tab displays only the data configured offline. Online data of the modules is not included.

⑨ "Statistics" tab (CPU31x PN/DP ≥ V3.2.1 and STEP 7 V5.5)

The tab is displayed for PROFINET IO devices only. It contains the following information related to the communication statistics of the selected IO device.

- Overall statistics - Data packets sent

You can assess the quality of data transmission on the send line based on the key data in this info box.

- Overall statistics - Data packets received

The quality of the data transfer on the reception line can be determined from the key data in this info box.

- "Statistics port x - Data packets transmitted"

The quality of the data transfer on the send line can be determined from the key data in this info box.

- "Statistics port x - Data packets received"

The quality of the data transfer on the reception line can be determined from the key data in this info box.

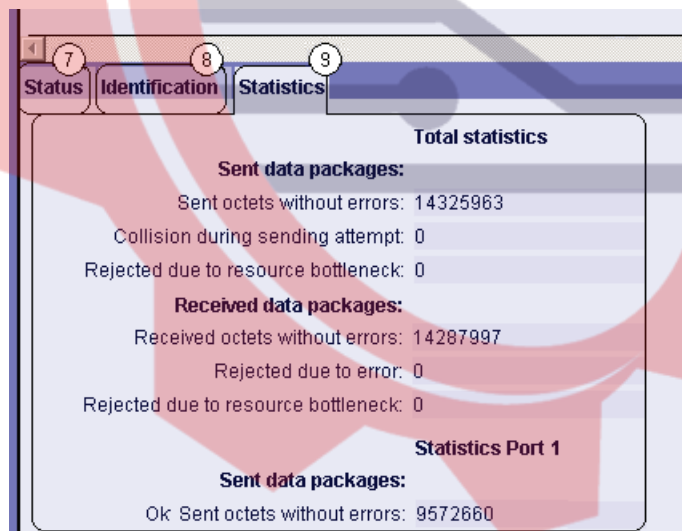

Reference

Refer to the "Statistics" tab in the "Communication" (Page 114) chapter.

Example: Module information - module

The screenshot displays the 'Module information' page in the SIMATIC Manager. The title bar shows 'SIEMENS CPU 317/CPU 317-2 PN/DP' and the language is set to 'English'. The main content area features a table of modules and a status section.

Slot	Symbol	Name	Order number	I Addr.	O Addr.	Comment
0	✓	IM151-3PNHFV60-1	6ES7 151-3BA23-0AB0			
1	✓	PM-E DC24V	6ES7 138-4CA01-0AA0	8171		...Modul PM-E (3)
2	✓	4DI DC24V HF	6ES7 131-4BD01-0AB0	1.0		...Modul 4DI (3)
3	✗	2DO DC24V/0,5A HF	6ES7 132-4BB01-0AB0		1.0	...Modul 2DO (3)

Status Identification

PN device 3 on PN system 100 Slot: 3: Module removed
Name: IM151-3PN-1
Module: 4DI DC24V HF
I/O address: I36

Figure 3-9 Module information - module

ماکان کنترول

Example: Module information - submodule

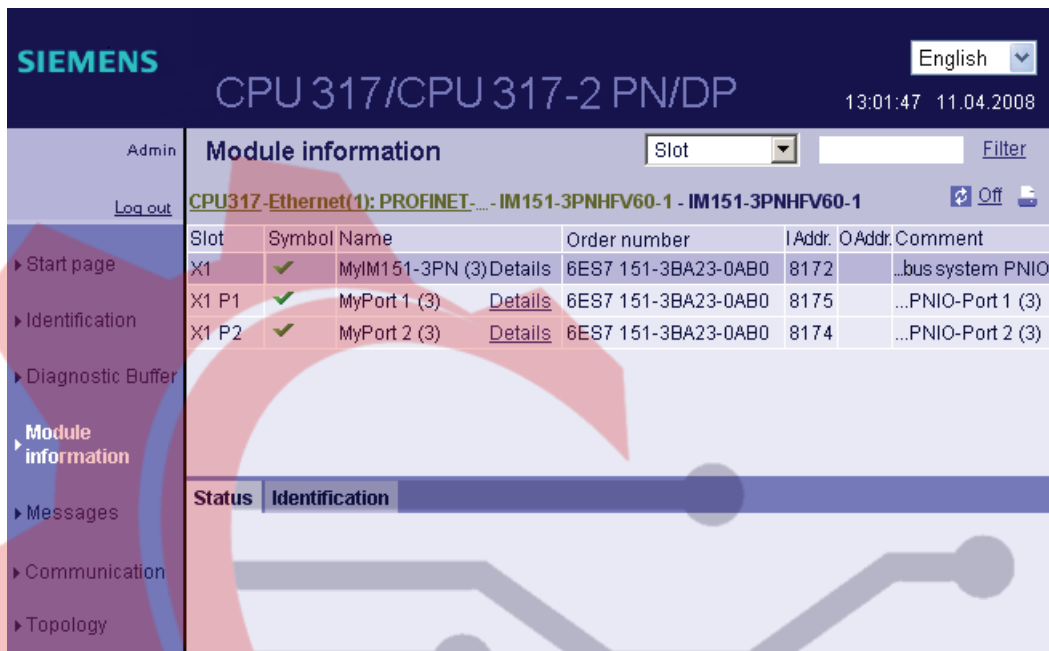

Figure 3-10 Module information - submodule

Reference

For additional information about "Module information" and about the topic "Configuring 'Report System Errors'", refer to the *STEP 7 Online Help*.

ماکان کنترول

3.7.4.5 Messages

Requirements

The message texts were configured in the user-specific languages. For information about configuring message texts refer to STEP 7 and to the Service&Support pages (<http://support.automation.siemens.com/WW/view/en/23872245>).

Messages

The browser displays the content of the message buffer on the "Messages" web page. The messages cannot be acknowledged on the web server.

The screenshot shows the Siemens Messages web page for a CPU 317/317-2 PN/DP. The page header includes the Siemens logo, the device name, the language (English), and the time (13:01:47) and date (11.04.2008). A navigation menu on the left includes links for Admin, Log out, Start page, Identification, Diagnostic Buffer, Module information, and Messages. The main content area displays a table of messages with the following data:

Message	Date	Time	Message text	Status	Acknowledg.
93	14.04.2008	08:23:24.644	PN device 5 on PN system....	incoming	not acknowledged
78	14.04.2008	08:23:24.796	PN device 4 on PN system....	incoming	not acknowledged
71	14.04.2008	08:23:24.948	PB slave 3, on PB system....	incoming	not acknowledged
70	14.04.2008	08:23:25.099	PB slave 1, on PB system....	incoming	not acknowledged
56	14.04.2008	08:23:25.251	PN device 3 on PN system....	incoming	not acknowledged
92	14.04.2008	08:23:25.402	PN device 2 on PN system....	incoming	not acknowledged
26	14.04.2008	08:23:25.553	PN device 1 on PN system....	incoming	not acknowledged

Below the table, there is a section titled "Details on message number: 93" with the short description: "SCALANCE-X204IRT Order number: 6GK5 204-0BA00-2BA3".

Figure 3-11 Messages

① "Filter"

You can filter the table based on specific criteria.

1. Select a parameter from the drop-down list box.
2. If applicable, enter the value of the selected parameter.
3. Click "Filter".

The filter criteria remain active after automatic page updates.

To deactivate the filter settings, click "Filter" again.

Effects

- The filter settings are also retained when you update a page.
- Filter settings have no effect on the print-out. A printout always contains the entire content of the message buffer.

② "Messages"

Messages of the CPU are displayed in the info field ② in chronological order, including **date** and **time**.

The **message text** parameter is an entry which contains the message texts configured for the corresponding fault definitions.

Sorting

You can also view the individual parameters in ascending or descending order. Click in the column header of one of the parameters:

- Message number
- Date
- Time
- Message text
- Status
- Acknowledgment

The messages are returned in chronological order when you click the "Date" entry. Incoming and outgoing events are output at the **Status** parameter.

③ "Message number details"

You can view detailed message information in this info field. Select the corresponding message from the info field ②.

Special features when changing languages

You can change the language, e.g. from German to English, in the upper right corner. If you select a language or corresponding message texts you have not configured, the program returns a hexadecimal code instead of plain text information.

3.7.4.6 Communication

Overview

The "Communication" Web page provides more information about the following tabs:

- Parameters
- Statistics
- Resources
- Open User Communication

① "Parameters" tab

A summary of the information related to the integrated PROFINET interface of the CPU is available in the "Parameters" tab.

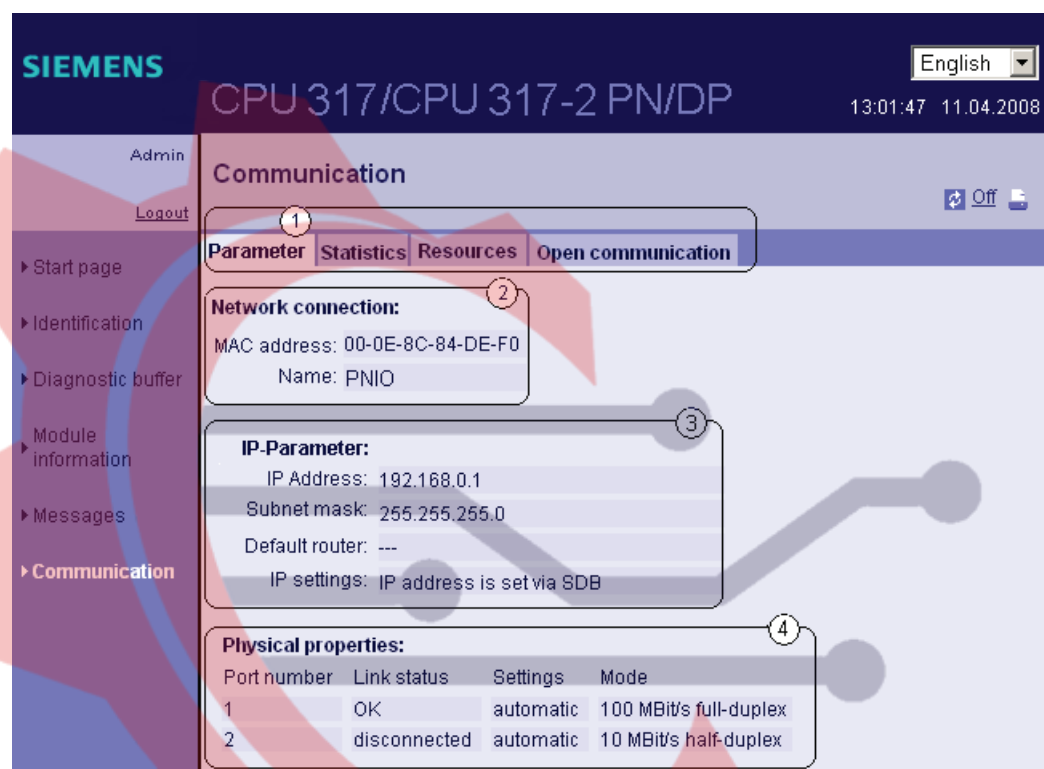

Figure 3-12 Parameters of the integrated PROFINET interface

② "Network connection"

This page displays information for the identification of the integrated PROFINET interface of the corresponding CPU.

③ "IP parameters"

Information about the configured IP address and number of the subnet to which the corresponding CPU is connected.

④ "Physical properties"

Information available in the "Physical properties" info field:

- Port number
- Link status
- Settings
- Mode

"Statistics" tab

Information about the quality of data transfers is available in the ① "Statistics" tab.

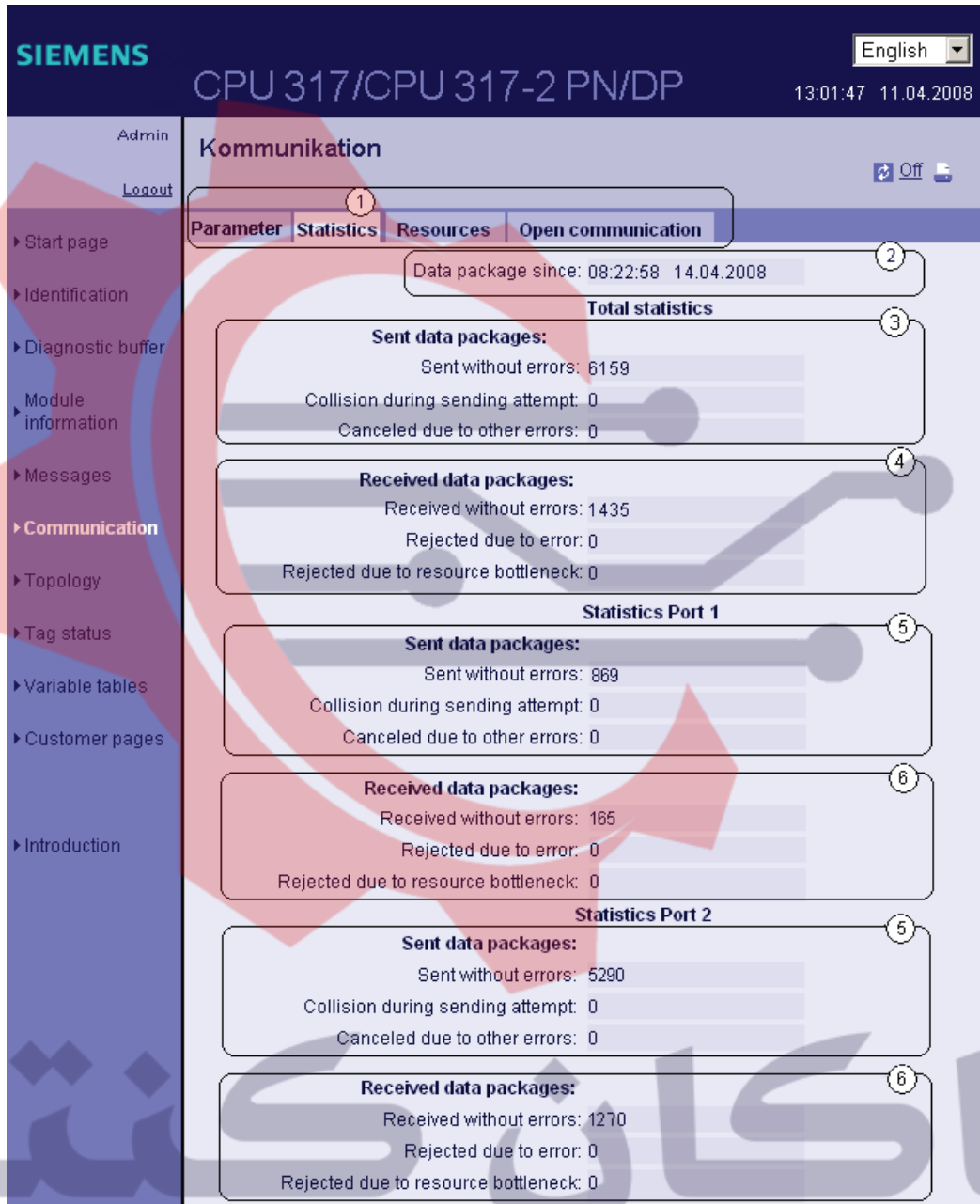

Figure 3-13 Data transfer key data

② "Data packets since"

This shows the time at which the first data packet was sent or received after the last Power on/memory reset.

③ "Overall statistics - Data packets sent"

The quality of the data transfer on the send line can be determined from the key data in this info box.

④ "Overall statistics - Data packets received"

The quality of the data transfer on the reception line can be determined from the key data in this info box.

⑤ "Statistics port x - Data packets transmitted"

The quality of the data transfer on the send line can be determined from the key data in this info box.

⑥ "Statistics port x - Data packets received"

The quality of the data transfer on the reception line can be determined from the key data in this info box.

① The "Resources" tab

For information about the load of connections on resources, refer to the "Resources" tab.

The screenshot shows the Siemens web server interface for a CPU 317/CPU 317-2 PN/DP. The page title is 'Kommunikation'. The 'Resources' tab is selected, showing connection statistics. A table lists connection types with reserved and assigned counts. Callouts 1, 2, and 3 point to the 'Resources' tab, the 'Number of connections' summary box, and the connection table respectively.

Connections:	reserved	assigned
PG communication	1	1
OP communication	1	0
S7 Basic communication	0	0
S7 communication	0	0
Other communication	--	0

② Number of connections

Provides information on the maximum number of connection resources currently not in use.

③ Connections

Provides information about the number of connections reserved or used for PG, OP, and S7 basic communication, S7 communication, and other communication functions.

"Open User Communication" tab

Information about the status of the communication links is available in the ① "Open User Communication" tab.

The screenshot shows the Siemens Web Server interface for a CPU 317/CPU 317-2 PN/DP. The top header displays the Siemens logo, the device name, and the time/date (13:01:47 11.04.2008). The left navigation menu includes options like Admin, Log out, Start page, Identification, Diagnostic buffer, Module information, Messages, Communication, Topology, Tag status, Variable tables, and Customer pages. The main content area is titled 'Communication' and has a tabbed interface with 'Open communication' selected. A table shows the status of three connections:

Status	ID	Remote IP	Type
✔ Connection has been set up	#16 0001	---	UDP
✘ Connection is being established a	#16 0002	192.168.3.148	TCP
✔ Connection has been established	#16 0003	192.168.3.148	ISO on TCP

Below the table, the 'Details: #16 0003' section provides further information:

- Local IP address: 192.168.3.147
- Local TSAP (hexadecimal): E0 02 AA
- Local TSAP (ASCII): ---
- Remote IP address: 192.168.3.148
- Remote TSAP (hexadecimal): E0 02 AA
- Remote TSAP (ASCII): ---
- Current connection establishment attempts: 0
- Successful connection establishment attempts: 1
- Bytes sent: 94139340
- Bytes received: 60496560
- Error message of last disconnection: ---
- Error message of last connection establishment attempts: ---

② Status information

Provides an overview of Open User Communication connections on Industrial Ethernet which are currently being set up and of those which are already active or configured.



The table contains the following information for each connection:

- "Status" column: Connection status, including the symbol
- "ID" column: Connection ID
- "Remote IP" column: Remote IP address
- "Type" column: Connection type

The possible connection states depend on the connection type. This dependency is shown in the following table:

Connection type	Possible connection states	Meaning
TCP, ISO on TCP	An active/passive connection is set up.	You called the TCON block to initiate the request for an active/passive connection.
	An active/passive connection is set up.	The connection initiated with the TCON block is set up.
UDP	Connection is configured	-

The following symbols are used to indicate the connection status:

Symbol	Color	Meaning
	green	<ul style="list-style-type: none"> • Connection is configured (for UDP) • An active/passive connection is set up (for TCP and ISO on TCP)
	red	<ul style="list-style-type: none"> • An active/passive connection is being set up (for TCP and ISO on TCP)

③ Details

Provides more information about the connection selected.

Reference

For information about the error messages possibly displayed due to cancellation or failed attempts to set up a connection, refer to the STEP 7 Online Help.

3.7.4.7 Topology

Topology of the PROFINET nodes

The "Topology" Web page provides information about the topological configuration and status of the PROFINET devices on your PROFINET IO system.

There are three tabs for the following views:

- Graphical view (target and actual topology)
- Tabular view (actual topology only)
- Status overview (excluding topological correlations)

The tabular view and status overview can be printed. Before printing, use the print preview of your browser and, if necessary, correct the format.

Target topology

In the Topology Editor of STEP 7, display of the configured topology of PROFINET devices set up on a PROFINET IO system, including corresponding status information. The display includes neighboring PROFINET devices, provided their topological layout is configured as well. However, a status view is not provided at this point.

The view identifies the topological assignment of PROFINET devices that have failed, the differences between the target and actual topology, and interchanged ports.

Note

The configured target topology is always displayed in the following scenarios:

- When the "Topology" web page is called via the navigation bar
- When you change from the overview of PROFINET IO devices on the "Module information" Web page to the "Topology" Web page by means of "Topology" link

If no target topology was configured, the actual topology is called by default.

Actual topology

Displays the actual topological layout of the "configured" PROFINET devices and the directly adjacent, non-configured PROFINET devices (display of the relations, provided these can be determined. However, the status of these adjacent PROFINET devices is not displayed).

Requirements

For error-free operation of the topology, the following conditions must be met:

- You completed the language settings.
- In the Topology Editor of STEP 7, you configured the topological interconnection of ports (requisite for the display of the target topology and corresponding topological target connections).
- You compiled the configuration data in HW Config.
- "Report system errors" is generated.
- The download of all project data is completed (configuration and program data).

Target and actual topology - graphical view

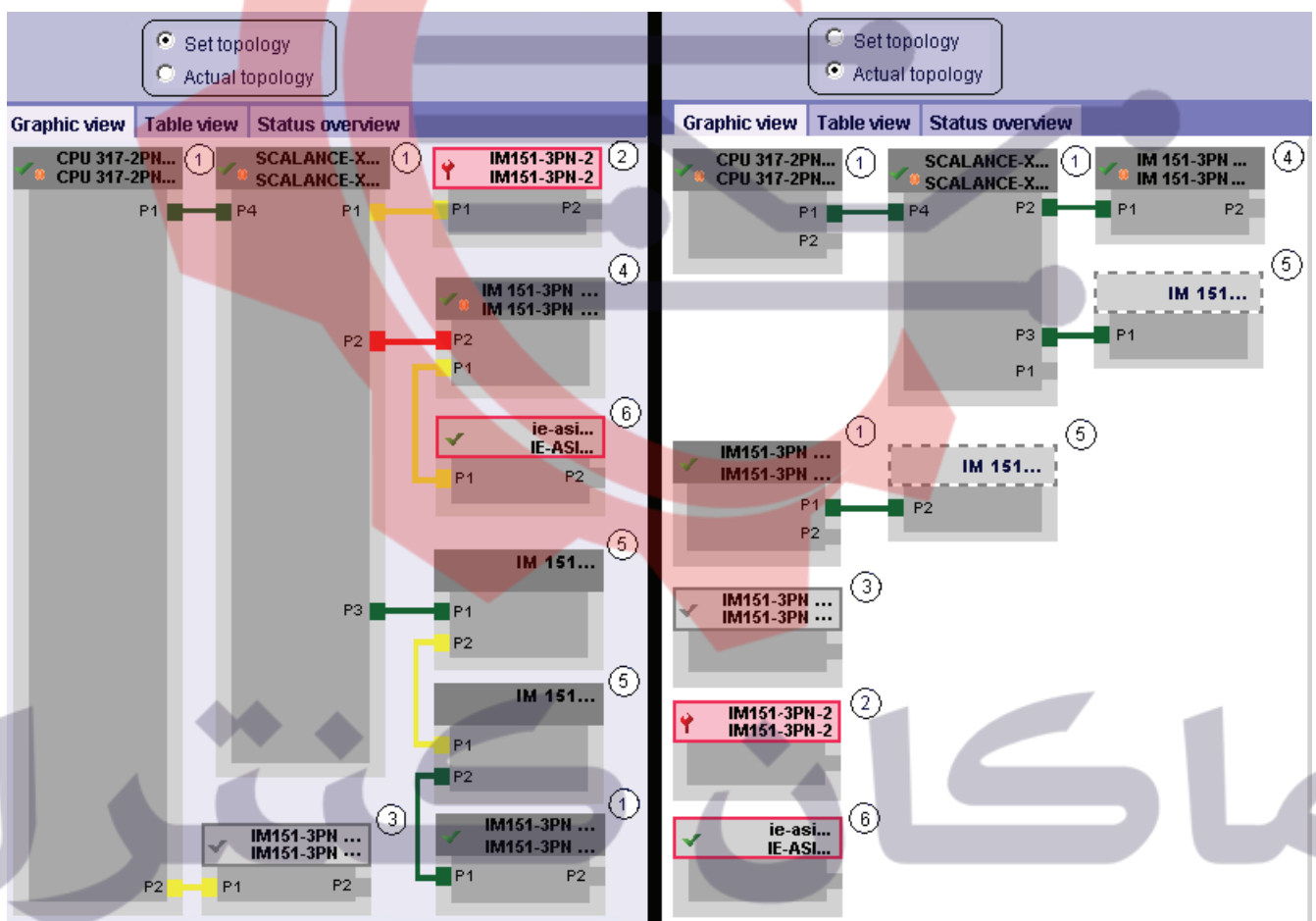

Figure 3-14 Graphical view - Target and actual topology

Meaning of the colored connections in the target/actual topology:

Connection	Meaning	
	Target topology	Actual topology
green	The current actual connection matches the configured target connection.	Connections detected
red	Mismatch between the current actual connection and the configured target connection (e.g., port interchanged).	-
yellow	Connection diagnostics not possible. Causes: <ul style="list-style-type: none"> • Malfunction of communication with a device (e.g. cable was removed) • Connection to a passive component • Connection to devices/PROFINET devices on a different IO controller or IO subsystem. 	-

① **Configured and accessible PROFINET nodes**

Configured and accessible PROFINET nodes are displayed in dark gray. Display the ports used to connect the PROFINET nodes of a station.

② **Configured but inaccessible PROFINET nodes**

Configured but inaccessible PROFINET nodes are indicated in pink color with red frame (e.g. device failure, cable disconnected)

③ **Deactivated nodes**

All disabled configured PROFINET nodes are indicated in light gray.

④ **Interchanged ports**

Interchanged ports are highlighted in red color in the target topology view. The actual topology view indicates the actually connected ports, while the target topology view displays the configured target connections.

ماکان کنترول

⑤ PROFINET devices of a different PROFINET IO subsystem

- In the target topology:

A PROFINET device of a different PROFINET IO subsystem is identified by means of a green link (or red link for interchanged ports) if available on the bus and directly adjacent to an accessible configured PROFINET device ①.

A PROFINET device that cannot be accessed from a different PROFINET IO subsystem is identified by means of a yellow link.

The connection between two PROFINET devices which belong to a different PROFINET IO subsystem cannot be identified and is always indicated in yellow color.

- In the actual topology:

The PROFINET device of a different PROFINET IO subsystem is not displayed unless directly adjacent to a configured PROFINET device. This device is indicated by means of a light gray dashed line.

The status of PROFINET devices of a different PROFINET IO subsystem is **not** displayed in the device header.

⑥ Displaying faulty neighbor relationships

Nodes whose relation data could not be read completely or with error are highlighted in light gray with a red frame.

Note

Displaying faulty neighbor relationships

A firmware update of the affected component is required.

Views after changes to the configuration

- After having failed, this device remains at the same position in the "Target topology" view. This error state is indicated by means of a device header with red frame and a red wrench 🛠.
- After having failed, the device is displayed in the bottom area of the in the "Actual topology" view. This error state is indicated by means of a device header with red frame and a red wrench.

Link between the "Topology" and "Module information" Web pages

The two web pages, "Topology" and "Module information", are linked. A click on the header of a selected module in the topology view automatically takes you to this module on the "Module information" Web page.

See also the "Module information (Page 106)" chapter.

Topology - tabular view

The "Tabular view" always shows the "Actual topology".

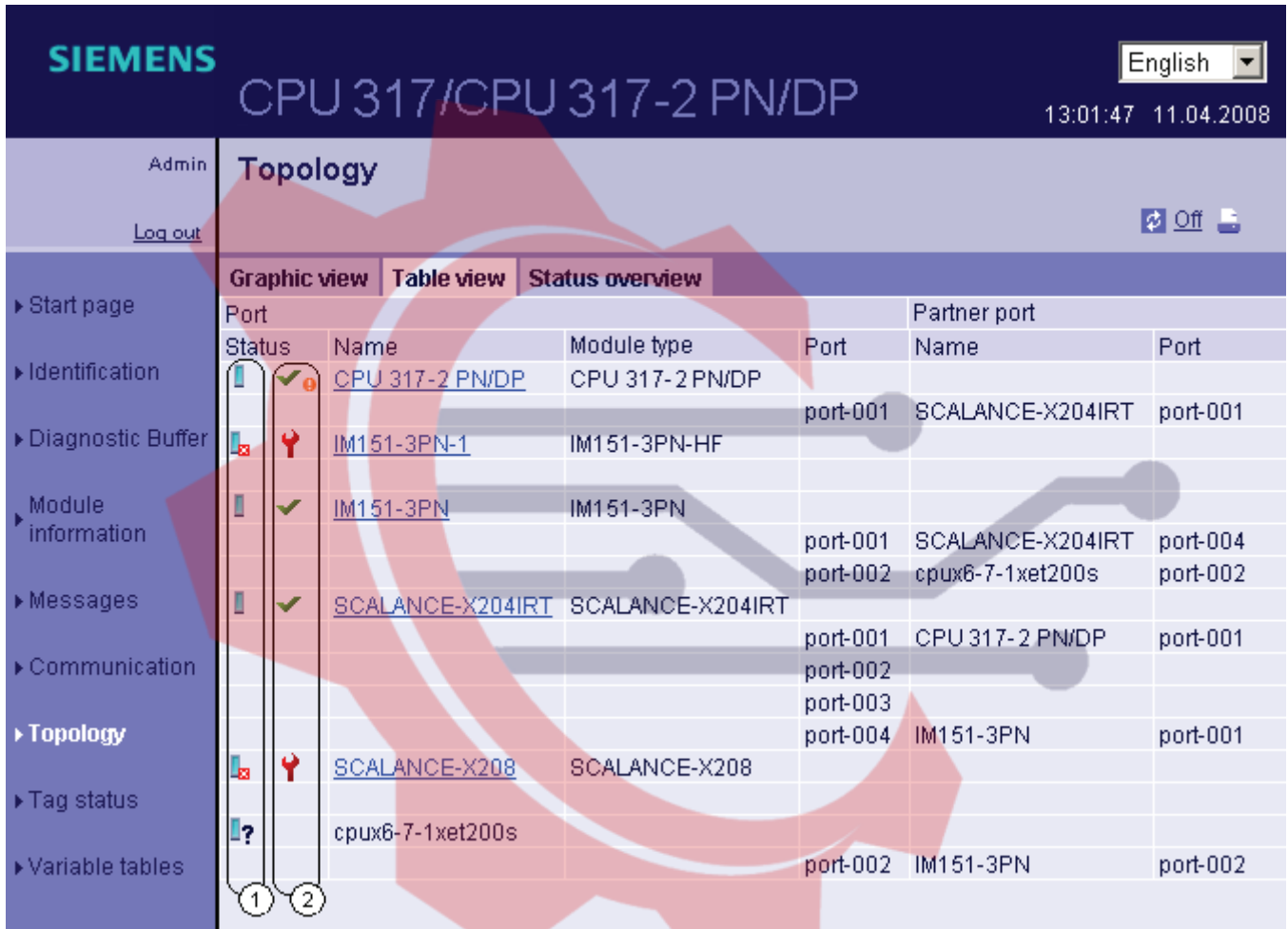









Figure 3-15 Topology - tabular view

① Meaning of the symbols relating to the status of the PROFINET nodes

Symbol	Meaning
	Configured and accessible PROFINET nodes
	Unconfigured and accessible PROFINET nodes
	Configured but inaccessible PROFINET nodes
	Nodes for which neighbor relations cannot be determined or for which the neighbor relationship could not be read out completely or only with errors

① Meaning of the symbols relating to the module status of the PROFINET nodes

Symbol	Color	Meaning
	green	Component is OK
	gray	Disabled PROFIBUS slaves or PROFINET devices Support conditions: <ul style="list-style-type: none"> • CPU31x PN/DP ≥ V3.2.1 and STEP 7 V5.5 + possibly required HSP for the CPU • Enabling/disabling the PROFIBUS slaves and PROFINET IO devices using SFC12 mode 3/4. • In the "Report system errors" dialog, "Diagnostics support" tab, "Status enabled/disabled" area, the check mark must be set in the "Request device status enabled/disabled" check box after CPU startup and optionally in the "Output message on status transition" check box.
	black	Component cannot be accessed/Status cannot be determined <ul style="list-style-type: none"> • For example, "Status cannot be determined" is always displayed while the CPU is in STOP mode, or during startup evaluation of "Report system error" for all the configured I/O modules and I/O systems after a CPU restart. • However, this status can also be displayed temporarily during operation if a diagnostic interrupt burst occurs at all modules. • It is not possible to determine the status of modules on a subsystem that is connected to a CP.
	green	Maintenance required
	yellow	Maintenance requested
	red	Error - component failed or faulty
	-	Error in a lower module level

ماکان کنترول

Topology - status overview

The "Status overview" provides a clear presentation of all PROFINET IO devices/PROFINET devices (without connection relations) on one page. A quick error diagnostics is possible based on the symbols that show the module statuses.

The overview also provides a link of the modules to the "Module information (Page 106)" Web page.

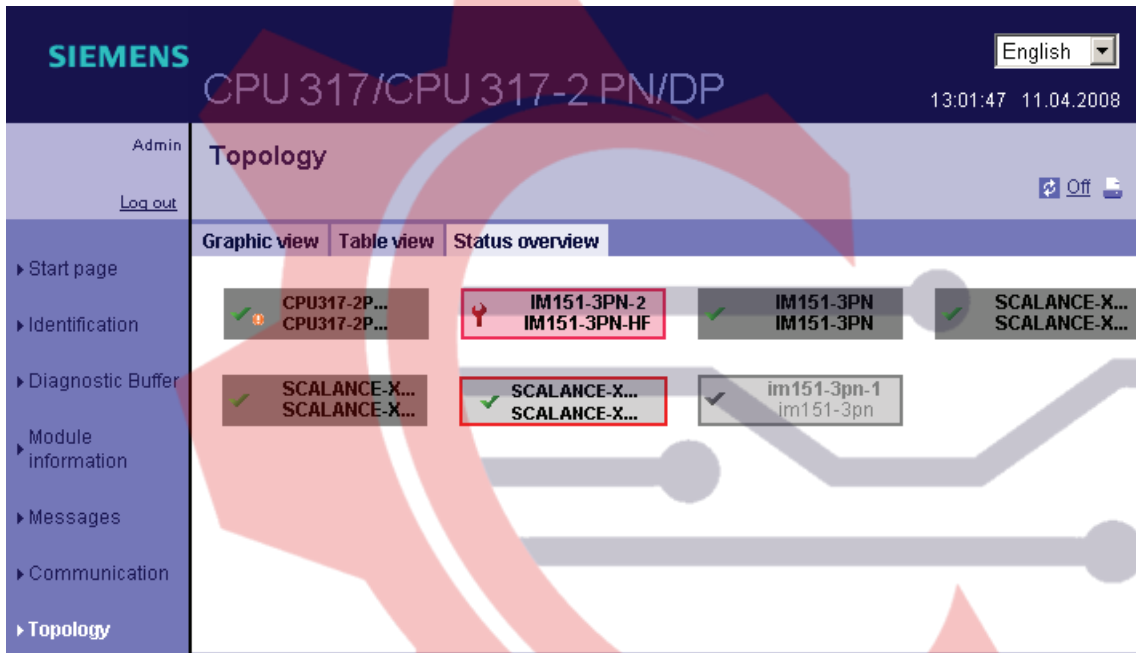

Figure 3-16 Topology - status overview

ماکان کنترول

3.7.4.8 Status of the variables

Status of the variables

The browser outputs the variable status on the web page of the same name. You can monitor the status of up to 50 variables.

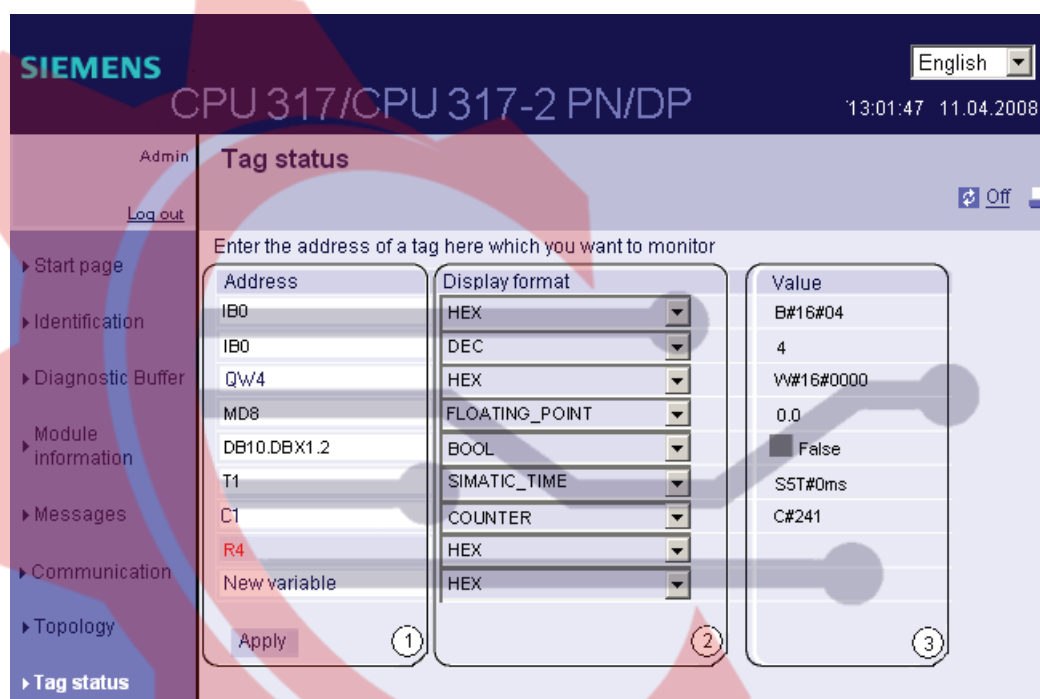

Figure 3-17 Status of the variables

① "Address"

In the "Address" text field, enter the address of the operand whose behavior you want to monitor. Invalid addresses entered are displayed in red font.

② "Display format"

Select the required display format of a variable in the drop-down list box. The variable is displayed in hexadecimal code if it cannot be displayed in the selected display format.

③ "Value"

Outputs the value of the corresponding operand in the selected format.

Special features when changing languages

You can change the language, e.g. from German to English, in the upper right corner. The German mnemonics differ compared to other languages. The syntax of operands you enter may therefore be invalid when you change languages. For example: ABxy instead of QBxy. The browser outputs a faulty syntax in red font.

3.7.4.9 Variable tables

Variable tables

The browser displays the content of the variable tables which support Web functionality on the Web page of the same name.

You can monitor up to 200 variables in each variable table.

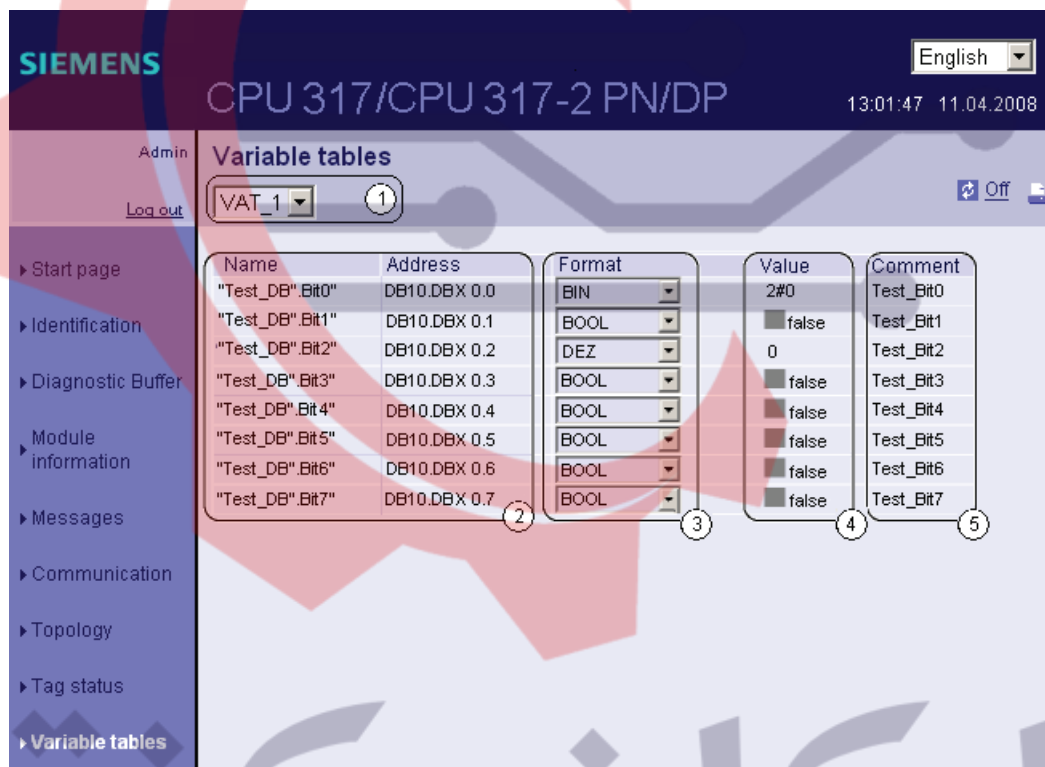

Figure 3-18 Variable tables

① Selection

Select one of the configured variable tables from this drop-down list box.

② "Name" and "Address"

This info field indicates the operand's name and address.

③ "Format"

Select the display format of the corresponding operand using the drop-down list boxes. The drop-down list box outputs a selection of all valid display formats.

④ "Value"

This column shows the values in the corresponding display format.

⑤ "Comment"

The comment you configured is shown in order to highlight the meaning of an operand.

Configuring variable tables for the web server

The web server lets you monitor up to 50 variable tables with up to 200 variables each. As the available CPU memory is shared by messages and variables, the actually available number of variable tables may be reduced.

Example: There is sufficient memory space for approximately 400 configured messages and 50 variable tables with 100 variables each (including the symbol names, but without symbol comment).

The web browser only outputs partial variable tables if memory capacity is exceeded due to the number of configured messages and variables. You counteract this negative effect by reducing memory requirements for your messages and symbol comments. You should also use only one language to display information, if possible.

You should also configure your variable tables with as few variables as possible, with short names and comments, in order to ensure that the variable tables are displayed in full by the web server and will also be updated faster than tables containing a large number of variables (limited memory of the CPU).

ماكان كنترول

Creating a variable table for the web server

1. Generate a variable table in STEP 7.
2. Open the properties dialog of the variable table and select the "General - Part 2" tab.
3. Activate the "Web server" checkbox.

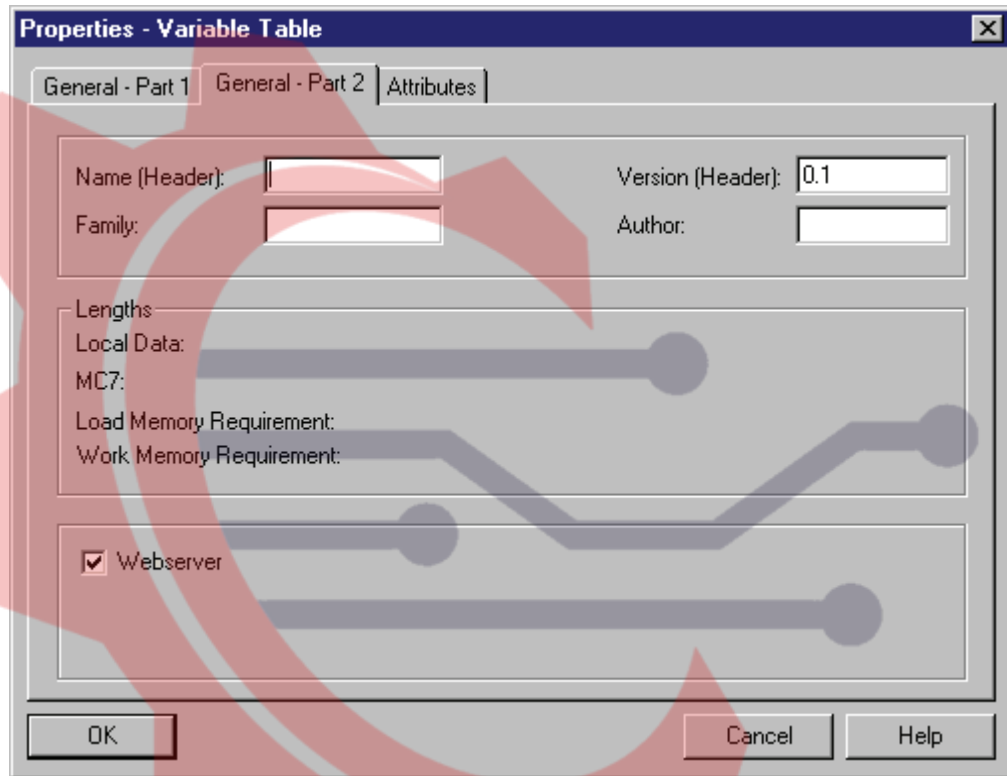

4. Save and compile the project and download the configuration data to the CPU.

ماكان كنترول

3.7.4.10 User pages

User pages

This Web page provides the link to your programmable user page.

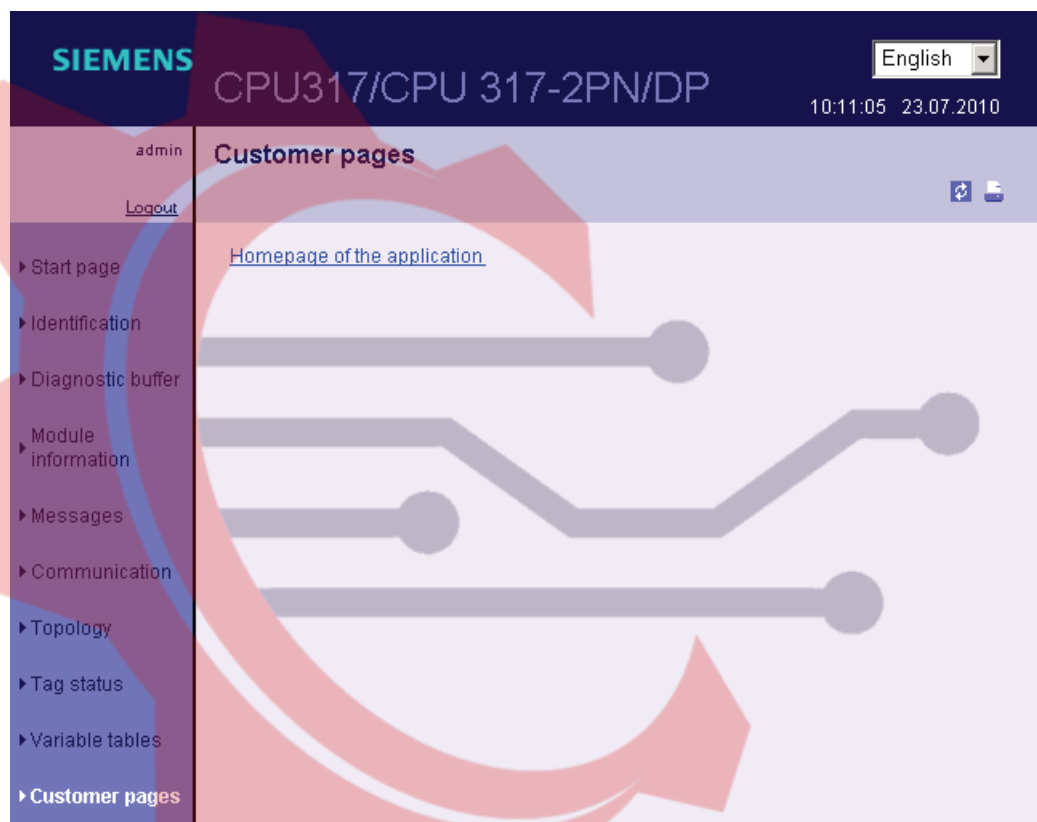

Figure 3-19 User pages

The Web server allows you to create user-specific HTML pages with CPU data content. Accordingly, create the user page in a Web Editor of your choice, using the symbols from the STEP 7 user program. The Web2PLC application included with your STEP 7 package converts the user page you created into data blocks. These DBs are downloaded to the CPU. System function SFC 99 "WWW" links the user program to the internal Web server on the CPU. At the first call of SFC 99 "WWW", the link to the user page is displayed on the CPU's Web page. A click on the link opens the user page in a new window.

No more than two user pages can be activated at any given time.

Requirements

- In your STEP 7 project, you have created the symbols for the I/O variables you want to use on your user page
- On the "Web" tab of the CPU properties dialog, you have at least:
 - activated the Web server
 - entered a user in the user list
 - assigned this (and other) user read/write authorizations (see chapter "Settings in HW Config, 'Web' tab" (Page 97))
- You completed all necessary communication settings (IP address parameter, subnet mask, etc.)
- You saved and downloaded the hardware configuration
- You created your user page in an HTML Editor of your choice:
 - Automatic HTML pages, if you want to **disable** control the page layout by means of the user program (requires at least one call of SFC 99)
 - Manual HTML pages, if you want to **enable** control the page layout by means of the user program (requires the cyclic call of SFC 99)
- You installed the Web2PLC application for STEP 7 included on your product CD (installation path: CD2: \Optional Components\S7 Web2PLC)

ماکان کنترول

Creating dynamic user pages

To create dynamic user pages, use AWP commands (Advanced Web Programming) on your HTML user page. AWP commands represent a Siemens instruction set that can be used to access CPU information. For information on AWP commands, refer to the Web2PLC Online Help.

Procedure

1. In SIMATIC Manager, select the "Blocks" folder in the S7 program of the CPU and then select "S7-Web2PLC" from the shortcut menu. The S7-Web2PLC program starts.
2. Select **File > New project...** and enter a project name.
3. Select **File > Edit project settings ...** .
The project settings dialog opens.
4. On the "General" tab, specify the path to your HTML folder.
5. Specify the HTML file to start as user page and the application name.
6. On the "STEP 7" tab, specify the DB numbers (default is 333 and 334)
Confirm your entries with **OK**. The dialog for the STEP 7/Web project opens.
7. Open your user page in the HTML Editor. Using the AWP commands and symbolic names from STEP 7, reference the variables to be available on your user page. Consult the Web2PLC Online Help.
8. Once you have edited and saved the HTML page, return to your S7-Web2PLC project. Click the following buttons in succession:
 - "Export symbols"
 - "Generate DB source"
 - "Compile DB source"

The corresponding actions are carried out and a control DB ("Web DB"), including at least one fragment DB, will be created in the "Blocks" folder of the S7 program of the CPU.

9. Click the "Download to CPU" to download the DBs to the CPU.

Note

The CPU should be in STOP mode before you run this operation. If memory resources are exceeded during the download of WEB DBs in RUN mode, synchronization errors could develop when the user program accesses the control DB.

Reference

For more information and a description of the areas that you can modify, refer to the Web2PLC Online Help.

For additional information about the SFC 99 block, refer to the *STEP 7 Online Help*.

For more information on visualization with user-defined web pages on SIMATIC CPUs with PROFINET interface, refer to the Internet (<http://support.automation.siemens.com/WW/view/en/44212999>).



ماكان كنترول

PROFINET

4.1 Communication via PROFINET

4.1.1 Introduction

What is PROFINET?

Within the framework of Totally Integrated Automation (TIA), PROFINET represents a consistent continuation of:

- PROFIBUS DP, the established fieldbus and
- Industrial Ethernet, the communication bus for the cell level

Experience gained from both systems was and is being integrated into PROFINET.

PROFINET is an Ethernet-based automation standard of PROFIBUS International (previously PROFIBUS user organization) and defines a multi-vendor communication, automation, and engineering model.

Objectives of PROFINET

The objectives of PROFINET are:

- Open Ethernet standard for automation based on Industrial Ethernet.
Although Industrial Ethernet and standard Ethernet components can be used together, the Industrial Ethernet devices are more rugged and therefore better suited for industrial environments (temperature, resistance, etc.)
- Use of TCP/IP and IT standards
- Automation with real-time Ethernet
- Seamless integration of fieldbus systems

Implementing PROFINET in SIMATIC

We have implemented PROFINET as follows:

- Communication between field devices is implemented in SIMATIC by way of **PROFINET IO**.
- Communication between controllers which operate as components in distributed systems is implemented in SIMATIC by means of **PROFINET CBA** (Component Based Automation).
- Installation engineering and network components are available as SIMATIC NET products.
- Established IT standards from the office environment (e.g. SNMP = Simple Network Management Protocol for network parameterization and diagnostics) are used for remote maintenance and network diagnostics.

Documentation from PROFIBUS International on the Internet

Abundant documentation related to PROFINET is available at the Internet URL (<http://www.profinet.com>) of PROFIBUS & PROFINET International (formerly the PROFIBUS User Organization, PNO).

Additional information can be found on the Internet (<http://www.siemens.com/profinet>).

What is PROFINET IO?

Within the framework of PROFINET, PROFINET IO is a communication concept for the implementation of modular, distributed applications.

PROFINET IO allows you to create automation solutions which are familiar to you from PROFIBUS.

PROFINET IO is implemented based on the PROFINET standard for programmable controllers.

The STEP 7 engineering tool supports engineering and configuring of an automation solution.

STEP 7 therefore provides the same application view, regardless of whether you are configuring PROFINET or PROFIBUS devices. Generally speaking, the programs for your PROFINET IO and PROFIBUS DP applications are identical, however, for PROFINET IO you must use the extended SFCs/SFBs and system status lists.

What is PROFINET CBA (Component Based Automation)?

Within the PROFINET system, PROFINET CBA (Component Based Automation) is an automation concept that focuses on the following:

- Implementation of modular applications
- Machine to machine communication

PROFINET CBA lets you create distributed automation solutions based on ready-to-use components and partial solutions. This concept meets demands for a higher degree of modularity in the field of mechanical and systems engineering through extensive distribution of intelligent processes.

Component Based Automation allows you to implement complete technological modules form operation as standardized components in large-scale systems.

You create the modular, intelligent components of PROFINET CBA using an engineering tool that could differ depending on the device manufacturer. Components that consist of SIMATIC devices are created in STEP 7 and interconnected using the SIMATIC iMAP tool.

Distinguishing features of PROFINET IO and PROFINET CBA

PROFINET IO and CBA represent two different views of automation devices on Industrial Ethernet.

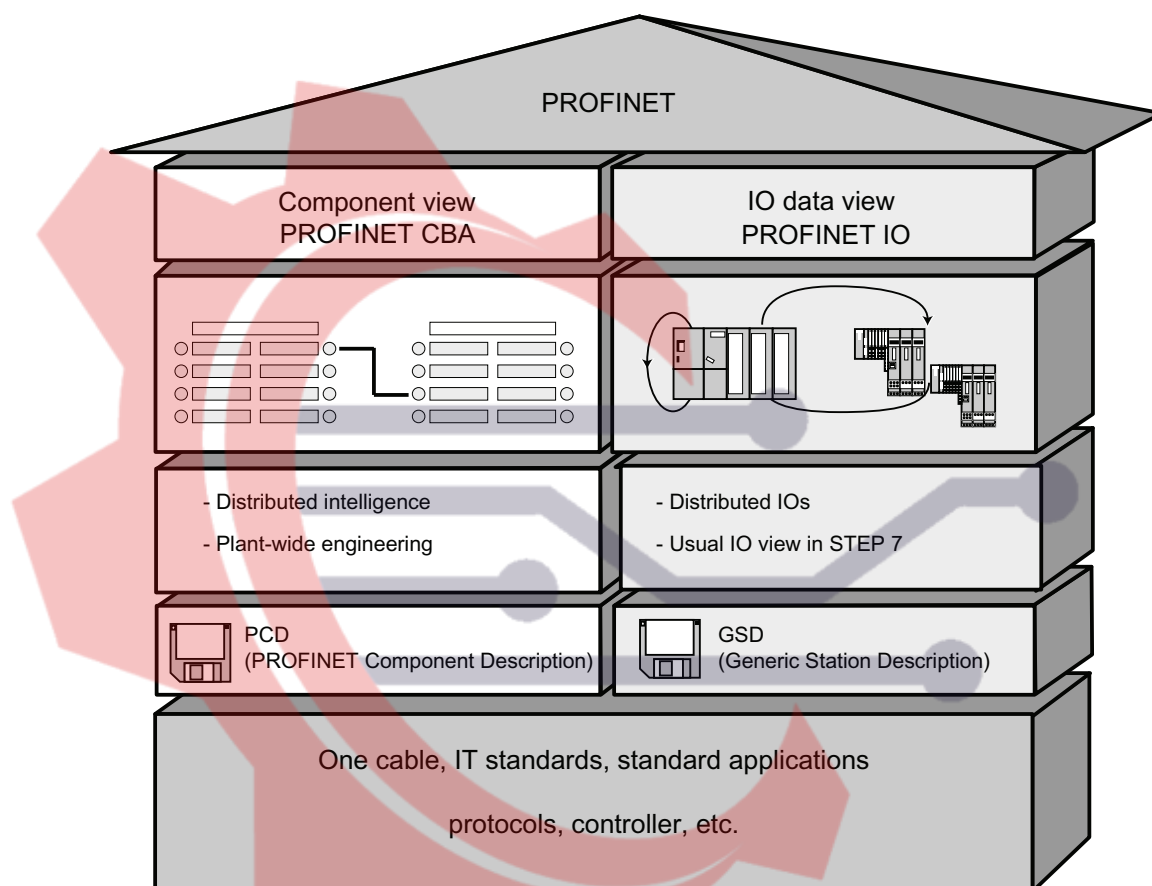

Figure 4-1 Distinguishing features of PROFINET IO and Component Based Automation

Component Based Automation divides the entire plant into various functions. These functions are configured and programmed.

PROFINET IO provides you with a view of the plant that is very similar to the PROFIBUS view. You continue to configure and program the individual programmable controllers.

Reference

Further information

- on PROFINET IO and PROFINET CBA is available in the *PROFINET system description*. For differences and similarities between PROFIBUS DP and PROFINET IO, refer to the *From PROFIBUS DP to PROFINET IO* programming manual.
- For detailed information about PROFINET CBA, refer to the documentation on SIMATIC iMap and Component Based Automation.

4.1.2 PROFINET IO System

Functions of PROFINET IO

The following graphic shows the new functions in PROFINET IO:

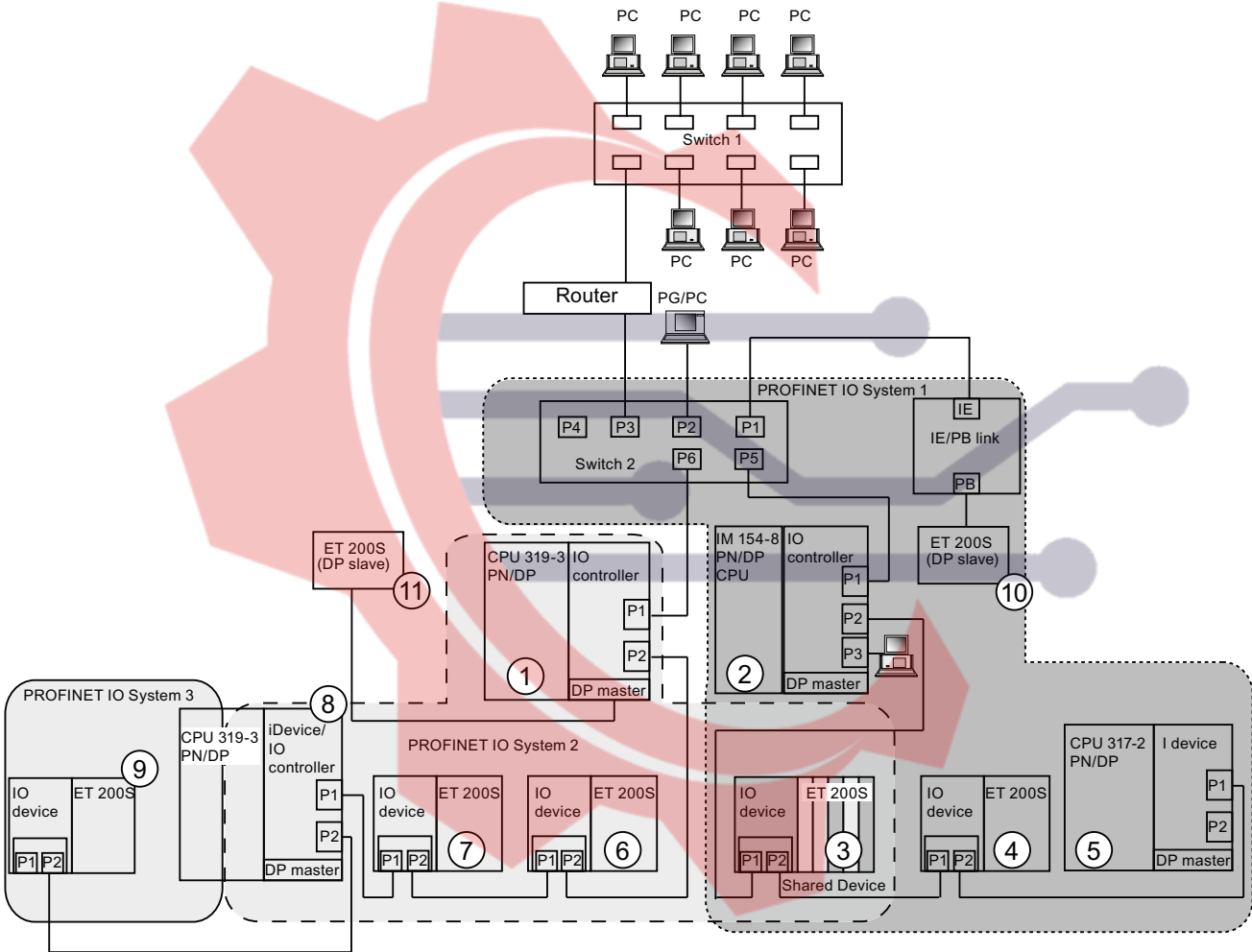

The graphic shows	Examples of connection paths
The connection of company network and field level	You can access devices at the field level from PCs in your company network Example: <ul style="list-style-type: none"> PC - Switch 1 - Router - Switch 2 - CPU 319-3 PN/DP ①.
Connections between the automation system and field level	You can also access other areas on the Industrial Ethernet from a programming device at the field level. Example: <ul style="list-style-type: none"> PG - integrated switch IM 154-8 CPU ② - Switch 2 - integrated switch CPU 319-3 PN/DP ① - integrated switch IO Device ET 200 S ⑥ - on IO Device ET 200 S ⑦.

The graphic shows	Examples of connection paths
<p>The IO controller of the CPU IM 154-8 CPU ② sets up PROFINET IO system 1 and directly controls devices on the Industrial Ethernet and PROFIBUS.</p>	<p>At this point, you can see the IO feature between the IO controller, intelligent device, and the IO devices on the Industrial Ethernet:</p> <ul style="list-style-type: none"> • IM 154-8 CPU ② acts as IO controller for the IO devices ET 200S ③ and ET 200S ④, for switch 2, and for the intelligent device CPU 317-2 PN/DP ⑤. • IO device ET 200S ③ is operated as shared device, which means that IM154-8 CPU ② operating as controller can access only the (sub)modules it has been assigned as controller for that IO device. • The IM 154-8 CPU ② is also the IO controller for ET 200S (DP slave) ⑩ by way of IE/PB Link.
<p>The CPU 319-3 PN/DP ① operates as IO controller for PROFINET system 2 and, at the same time, as DP master on the PROFIBUS. In addition to other IO devices, this IO controller is used to operate a CPU319-3 PN/DP ⑧ as intelligent device which, in turn, operates a PROFINET subsystem as IO controller.</p>	<p>Here you can see that a CPU can be both the IO controller for an IO device and the DP master for a DP slave:</p> <ul style="list-style-type: none"> • CPU 319-3 PN/DP ① is the IO controller for the IO devices ET 200S ⑥ and ET 200S ⑦, and for the intelligent device CPU 319-3 PN/DP ⑧. • Moreover, CPU319-3 PN/DP ① shares the IO device ET 200S ③ with IO controller IM 154-8 CPU ②, which means that the CPU319-3 PN/DP ① operating as controller can access only the (sub)modules it has been assigned as controller for that IO device. • CPU319-3 ⑧, which is operated as intelligent device on CPU319-3 PN/DP ①, also acts as IO controller and sets up its own PROFINET system 3 on which the IO device ET 200S ⑨ is operated. • The CPU 319-3 PN/DP ① is the DP master for one DP slave ⑪. The DP slave ⑪ is assigned locally CPU 319-3 PN/DP ① and is not visible on the Industrial Ethernet.

Further information

You will find further information about PROFINET in the documents listed below:

- In the System Description PROFINET
- In the *From PROFIBUS DP to PROFINET IO programming manual*. This manual also provides a clear overview of the new PROFINET blocks and system status lists.

4.1.3 Blocks for PROFINET IO

Content of this chapter

This chapter covers the following:

- Blocks designed for use with PROFINET
- Blocks designed for use with PROFIBUS DP
- Blocks designed for use with PROFINET IO and PROFIBUS DP

Compatibility of the new blocks

New blocks were implemented for PROFINET IO since PROFINET is capable of handling larger quantity frameworks, for example. The new blocks are also used for PROFIBUS.

Comparison of the system and standard functions of PROFINET IO and PROFIBUS DP

For CPUs with integrated PROFINET interface, the table below provides an overview of the following:

- System and standard functions for SIMATIC which you will have to replace with upgraded functions for migration from PROFIBUS DP to PROFINET IO
- New system and standard functions

Table 4- 1 System and standard functions which are new or have to be replaced

Blocks	PROFINET IO	PROFIBUS DP
SFC 5 (determine start address of a module)	No (replaced with: SFC 70)	Yes
SFC 12 (deactivation and activation of DP slaves/IO devices)	Yes CPU S7-300: FW V2.4 or higher	Yes
SFC13 (reading diagnostics data from a DP slave)	No Substitution: • Event-driven: SFB 54 • Status-driven: SFB 52	Yes
SFC 49 (determine the associated slot of a logical address)	No Substitution: SFC 71	Yes
SFC 58/59 (write/read record in I/O)	No Substitution: SFB 53/52	Yes Already replaced by SFB 53/52 in DPV1
SFC 70 (determine start address of a module)	Yes	Yes
SFC 71 (determine the associated slot of a logical address)	Yes	Yes

Blocks	PROFINET IO	PROFIBUS DP
SFC 102 (read predefined parameters - CPU S7-300 only)	No Substitution: SFB 81	Yes, for S7-300
SFB 52/53 (read/write data record)	Yes	Yes
SFB 54 (evaluate interrupt)	Yes	Yes
Receiving SFB 73 ((PROFenergy-) data records in the intelligent device from the higher-level controller)	Yes	No
providing SFB 74 ((PROFenergy-) data records in the intelligent device to the higher-level controller)	Yes	No
SFB 81 (read predefined parameters)	Yes	Yes
SFB 104 (assignment of the IP suite and/or device name by the user program)	Yes	No

The table below provides an overview of SIMATIC system and standard functions which must be emulated by other functions when migrating from PROFIBUS DP to PROFINET IO.

Table 4- 2 System and standard functions in PROFIBUS DP which can be emulated in PROFINET IO

Blocks	PROFINET IO	PROFIBUS DP
SFC 55 (write dynamic parameters)	No Emulate using SFB 53	Yes
SFC 56 (write predefined parameters)	No Emulate using SFB 81 and SFB 53	Yes
SFC 57 (assign module parameters)	No Emulate using SFB 81 and SFB 53	Yes

The following SIMATIC system and standard functions are not supported in PROFINET IO:

- SFC 7 (trigger hardware interrupt on DP master)
- SFC 11 (synchronize groups of DP slaves)
- SFC 72 (read data from communication peer within own S7 station)
- SFC 73 (write data to communication peer within own S7 station)
- SFC 74 (interrupt connection to a communication peer within own S7 station)
- SFC 103 (determine the bus topology in a DP master system)

Comparison of the organization blocks of PROFINET IO and PROFIBUS DP

The table below shows the changes to OB83 and OB86 in PROFINET IO compared to PROFIBUS DP.

Table 4- 3 OBs in PROFINET IO and PROFIBUS DP

Blocks	PROFINET IO	PROFIBUS DP
OB 83 (hot swapping of modules/submodules)	Also possible with S7-300, new error information	Not possible with S7-300 Slaves integrated via the GSD file report the removal/insertion of modules/submodules during operation in the form of a diagnostic interrupt and thus via OB 82. With S7 slaves, a station failure is reported and OB 86 is called when an insertion/removal interrupt is generated.
OB 83 (return-of-submodule interrupt for submodules of the transfer areas of an intelligent device)	Corresponding info about the submodules	Not relevant
OB 86 (station failure)	New error information	Unchanged
OB 86 (partial station failure/partial station recovery)	Possible if used as shared intelligent device	Not relevant

Detailed information

For detailed information about the individual blocks, refer to the *Reference Manual System Software S7-300/400 System and Standard Functions*.

ماکان کنترول

4.2 Isochronous real-time communication

Synchronized communication protocol for cyclic exchange of IRT data between PROFINET devices. A reserved bandwidth is available in the send cycle for IRT IO data.

The reserved bandwidth ensures that IRT data can be transmitted at reserved, synchronized intervals, without transmission being sensitive to high network load caused by other applications (for example, TCP/IP communication, or additional real-time communication).

PROFINET with IRT can be operated with the two following options:

- IRT option "high flexibility"
Maximum flexibility in terms of system planning and extensions.
A topological configuration is **not** required.
- IRT option "high performance":
A topological configuration is required.

Note

IO controller as sync master for IRT communication with IRT option "high performance"

For a configuration of IRT communication with "high performance" option, it is advisable to operate the IO controller as sync master as well. Otherwise, IO devices with IRT and RT configuration could fail as a result of sync master failure.

Additional information

For more information about the configuration of PROFINET devices, refer to the STEP 7 Online Help and to the PROFINET System Description (<http://support.automation.siemens.com/WW/view/en/19292127>) manual.

ماکان کنترول

4.3 Prioritized startup

Prioritized startup denotes a PROFINET functionality for acceleration of the startup of IO devices (distributed I/O) in a PROFINET IO system with RT and IRT communication.

The function reduces the time that configured IO devices require in order to return to cyclic user data exchange in the following scenarios:

- On recovery of the power supply (not for a CPU that is operated as intelligent device with prioritized startup)
- On station recovery
- On activation of IO devices

Note**Startup times**

The startup time depends on the number and type of modules.

Note**Prioritized startup and media redundancy**

You cannot add an IO device with prioritized startup to a ring topology with media redundancy.

Additional information

For additional information, refer to the STEP 7 Online Help and to the PROFINET System Description (<http://support.automation.siemens.com/WW/view/en/19292127>) manual.

ماکان کنترول

4.4 Device replacement without removable medium/programming device

IO devices having this function can be replaced in a simple manner:

- A removable medium (such as SIMATIC Micro Memory Card) with stored device name is not required.
- The device name does not have to be assigned with the programming device.

The replacement IO device is now assigned a device name from the IO controller. It is no longer assigned using a removable medium or programming device. The IO controller uses the configured topology and the relations determined by the IO devices. The configured target topology must match the actual topology.

Before reusing IO devices that you already had in operation, reset these to factory settings.

Additional information

For additional information, refer to the STEP 7 Online Help and to the PROFINET System Description (<http://support.automation.siemens.com/WW/view/en/19292127>) manual.

4.5 IO devices changing at runtime

Functionality of a PROFINET device. If the IO controller and IO devices support this functionality, other devices can assign the "changing partner ports" function to the port of an IO device by means of configuration, so that communication with each of these interchanging IO devices is possible at a specific time via this port. No other but the changing device can be physically connected to the changing port that is currently to be used for communication.

Note

The CPU ports cannot be assigned the "changing partner ports" function unless you operate the CPU as intelligent device. The function not available for CPU operation as IO controller.

Additional information

For additional information, refer to the STEP 7 Online Help and to the PROFINET System Description (<http://support.automation.siemens.com/WW/view/en/19292127>) manual.

4.6 Isochronous mode

The process data, transmission cycles via PROFINET IO, and the user program are synchronized in order to achieve ultimate deterministic. The input and output data of the distributed IO devices in the system is acquired and output simultaneously. The isochronous PROFINET IO cycle form the corresponding clock generator.

Note

The following components cannot be operated in isochronous mode:

- Shared devices
 - Intelligent devices on the higher-level IO controller
-

Note**Restrictions of the send clocks for isochronous applications**

The isochronous mode is possible on CPU 319-3 PN/DP starting at a send clock $\geq 500 \mu\text{s}$ and on CPU 31x PN/DP starting at 1 ms. The size of the topology and length of user data could make it necessary to increase the application cycle factor or the send clock in order to meet time requirements.

Additional information

For additional information, refer to the STEP 7 Online Help and to the PROFINET System Description (<http://support.automation.siemens.com/WW/view/en/19292127>) manual.

4.7 I-Device

The "I-Device" (intelligent IO device) functionality of a CPU facilitates data exchange with an IO controller and operation of the CPU, for example, as intelligent preprocessing unit of sub processes. In its role as an IO device, the I-Device is integrated accordingly into a "higher-level" IO controller.

The functionality of the intelligent device ensures that the data is pre-processed in the user program on the CPU. The process data acquired from central or distributed locations (PROFINET IO or PROFIBUS DP) is preprocessed by the user program made available to a higher-level station via PROFINET IO device interface of the CPU.

Note**Isochronous mode**

Intelligent IO devices cannot be operated in isochronous mode on higher-level IO controllers

Combination of functions

A CPU operated as intelligent IO device on a "higher-level" IO controller is, in turn, capable of operating as sublevel IO controller that controls IO devices on a subnet.

An intelligent IO device can also be operated as shared device.

Application transfer area

The IO controller and intelligent IO device communicate via the configured submodules of this transfer area. With regard to the submodules, transmission of the user data remains consistent.

Additional information

For more information about the configuration of intelligent IO devices, refer to the STEP 7 Online Help and to the PROFINET System Description (<http://support.automation.siemens.com/WW/view/en/19292127>) manual.

4.8 Shared Device

The "Shared Device" functionality facilitates distribution of the submodules of an IO device to different IO controllers. An intelligent IO device can also be operated as shared device.

Prerequisite for using the "Shared Device" function is that the IO controller and shared device are located on the same Ethernet subnet.

The IO controllers can be located in the same or different STEP 7 projects. If they are located in the same STEP 7 project, a consistency check is initiated automatically.

Note

Shared devices cannot be operated in isochronous mode.

Note

Note that the power modules and electronic modules belonging to the same potential group of a shared IO device (e.g. ET 200S) must be assigned to the same IO controller in order to enable the diagnosis of load voltage failure.

Additional information

For more information about shared devices and their configuration, refer to the STEP 7 Online Help and to the PROFINET System Description (<http://support.automation.siemens.com/WW/view/en/19292127>) manual.

4.9 Media redundancy

Function for safeguarding network and system availability. Redundant transmission links (ring topology) ensure that an alternative communication path is made available upon transmission link failure.

The Media Redundancy Protocol (MRP) is a component of PROFINET standardization to IEC 61158 and can be activated for IO devices, switches, and CPUs V3.2.1 or higher.

Configuring a ring topology

To set up a ring topology with media redundancy, you must route both free ends of a line network topology to the same device. To form a ring topology, join the line topology at two ports (ring ports) of a device that is connected to the ring. Select and specify the ring ports when configuring the relevant device.

The ring ports of the module are identified by the suffix "R" appended to the port number.

Note

IRT communication/prioritized startup

Media redundancy is not supported for operation with IRT communication or prioritized startup.

Additional information

For additional information, refer to the STEP 7 Online Help and to the PROFINET System Description (<http://support.automation.siemens.com/WW/view/en/19292127>) manual.

ماکان کنترول

Memory concept

5.1 Memory areas and retentivity

5.1.1 CPU memory areas

The three memory areas of your CPU

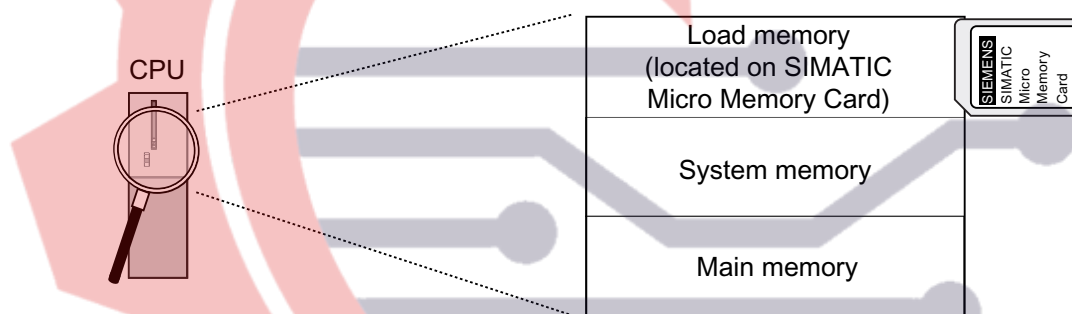

Load memory

The load memory is located on the SIMATIC Micro Memory Card. The size of the load memory corresponds exactly to the size of the SIMATIC Micro Memory Card. It is used to store code blocks, data blocks, and system data (configuration, connections, module parameters, etc.). Blocks that are identified as not relevant for execution are stored exclusively in the load memory. You can also store all the configuration data for your project on the SIMATIC Micro Memory Card.

Note

You must insert a SIMATIC Micro Memory Card into the CPU to enable loading of user programs and operation of the CPU.

System memory

The system memory is integrated in the CPU and cannot be expanded.

It contains

- the address areas for bit memories, timers, and counters
- the process images of the inputs and outputs
- local data

Main memory

The main memory is integrated in the CPU and cannot be extended. It is used to execute the code and process user program data. Programs only run in the main memory and system memory.

5.1.2 Retentivity of load memory, system memory, and main memory

Your CPU is equipped with a maintenance-free retentive memory, i.e. no back-up battery is required for its operation. Due to the retentivity, the content of the retentive memory is retained even during a POWER OFF and restart (warm restart).

Retentive data in the load memory

Your program in the load memory is always retentive: It is stored on the SIMATIC Micro Memory Card, where it is protected against power failures or memory resets

Retentive data in the system memory

In your configuration (Properties of CPU, Retentivity tab), specify which part of memory bits, timers and counters should be kept retentive and which of them are to be initialized with "0" on restart (warm restart).

The diagnostic buffer, MPI address (and baud rate), and runtime meter data are generally stored in the retentive memory area on the CPU. Retentivity of the MPI address and baud rate ensures that your CPU can continue to communicate, even after a power loss, memory reset, or loss of communication parameters (e.g. due to removal of the SIMATIC Micro Memory Card or deletion of communication parameters).

Retentive data in the main memory

The contents of retentive DBs are always retentive at restart and POWER ON/OFF. Retentive data blocks can be uploaded to the main memory in accordance with the maximum limit allowed by the main memory.

In the case of CPU versions V2.0.12 and higher, non-retentive DBs are also supported.

Non-retentive DBs are initialized from the load memory with their initial values at restart or POWER ON/OFF. Non-retentive data blocks and code blocks can be loaded in accordance with the maximum main memory limit.

The size of the retentive main memory (for retentive data blocks) of the CPU can be found in the chapters "Technical specifications of CPU 31x (Page 301)" and "Technical specifications of CPU 31xC (Page 213)".

See also

Properties of the SIMATIC Micro Memory Card (Page 158)

5.1.3 Retentivity of memory objects

Retentive behavior of the memory objects

The table below shows the retentive behavior of memory objects during specific operating state transitions.

Table 5- 1 Retentive behavior of the memory objects

Memory object	Operating state transition		
	POWER OFF / POWER ON	STOP → RUN	Memory reset
User program/data (load memory)	X	X	X
• Retentive behavior of DBs on CPUs with firmware < V2.0.12	X	X	–
• Retentive behavior of DBs on CPUs with firmware ≥ V2.0.12	Can be set in the properties of the DBs in STEP 7 V5.2 + SP1 or higher.		–
Bit memories, timers, and counters configured as retentive objects	X	X	–
Diagnostic buffer, runtime meter	X ¹	X	X
MPI address, baud rate of an MPI interface DP address, baud rate of an MPI/DP interface, if set as DP note in the parameter Note: After POWER OFF/ON and CPU memory reset, the parameters of a pure DP interface are not retained unless the parameter assignment (SDBs) was loaded	X	X	X
• IP suite/device name of the PROFINET interface	Depends on the type of assignment of the IP address parameters and of the device name	X	Depends on the type of assignment of the IP address parameters and of the device name

x = retentive; – = not retentive

¹ Only the last 100 entries in the diagnostics buffer are retained after POWER OFF / POWER ON.

Reference

For more information about the assignment of IP address parameters and device names, refer to the S7-300 - Installation Operating Instructions, chapter: IP address parameters and device name.

Retentive behavior of a DB for CPUs with firmware < V2.0.12

For these CPUs, the contents of the DBs are always retentive at POWER ON/OFF or STOP-RUN.

Retentive behavior of a DB for CPUs with firmware ≥ V2.0.12

These CPUs support the generation of data blocks with "NON-Retain" (not retentive) property.

Data blocks assigned the "NON-Retain" property are reset to their initial values after every POWER OFF/ON and every STOP-RUN transition of the CPU.

You have two options of assigning the "NON-Retain" property to a data block:

- STEP 7 (V5.2 + SP1 or higher): Activate the NON-Retain function in the DB properties
- SFC 82 "Crea_DBL" (generation of a DB in load memory): ATTRIB parameter, set bit 2 to "1"

Table 5- 2 Retentive behavior of DBs for CPUs with firmware ≥ V2.0.12

At POWER ON/OFF or restart of the CPU, the DB should	
be reset to the initial values (non-retentive DB)	retain the actual values (retentive DB)
Reason: At POWER ON/OFF and restart (STOP-RUN) of the CPU, the actual values of the DB are non-retentive. The DB receives the initial values from the load memory.	Reason: At POWER OFF/ON and restart (STOP-RUN) of the CPU, the actual values of the DB are retained.
Requirement in STEP 7: <ul style="list-style-type: none"> • The "Non-Retain" checkbox is activated in the DB properties. or • A non-retentive DB was generated using SFC 82 "CREA_DBL" and the associated block attribute (ATTRIB → Bit NON_RETAIN). 	Requirement in STEP 7: <ul style="list-style-type: none"> • The "Non-Retain" checkbox is deactivated in the DB properties. or • a retentive DB was generated using SFC 82 "CREA_DBL".

The size of the retentive main memory (for retentive data blocks) of the CPU can be found in the chapters "Technical specifications of CPU 31x (Page 301)" and "Technical specifications of CPU 31xC (Page 213)".



5.1.4 Address areas of the system memory

The system memory of the S7-CPU is divided into address areas. By using corresponding instructions in your program, you can address the data directly in the relevant address area.

Address areas of the system memory

Table 5- 3 Address areas of the system memory

Address areas	Description
Process input image	At every start of an OB 1 cycle, the CPU reads the input values from the input modules and saves them in the process input image.
Process output image	During the cycle, the program calculates the values for the outputs and stores them in the process output image. At the end of the OB 1 cycle, the CPU writes the calculated output values to the output modules.
Bit memory	This area provides memory for saving the intermediate results of a program calculation.
Timers	Timers are available in this area.
Counters	Counters are available in this area.
Local data	Temporary data of a code block (OB, FB, FC) is saved to this memory area while the block is being processed.
Data blocks	See <i>Recipes and measured value archives</i>

Reference

To find out which address areas are possible for your CPU, refer to the *S7-300 instruction lists* and the chapters Technical specifications of the CPU 31x (Page 301) and Technical specifications of the CPU 31xC (Page 213).

ماکان کنترول

Process input/output image

When the input (I) and output (O) address areas are addressed in the user program, the signal states of digital signal modules are not queried. Instead, a memory area in the CPU system memory is accessed. This memory area is the process image.

The process image has two sections: the process image of inputs, and the process image of outputs.

Advantages of the process image

Access to the process image, compared to direct access to the input/output modules, offers the advantage that a consistent image of process signals is made available to the CPU during cyclic program processing. If the signal state at an input module changes during program execution, the signal status in the process image is maintained until the process image is updated in the next cycle. Moreover, since the process image is stored in the CPU's system memory, access to the process image is significantly faster than direct access to the signal modules.

Process image update

The operating system updates the process image periodically. The figure below shows the sequence of this operation within a cycle.

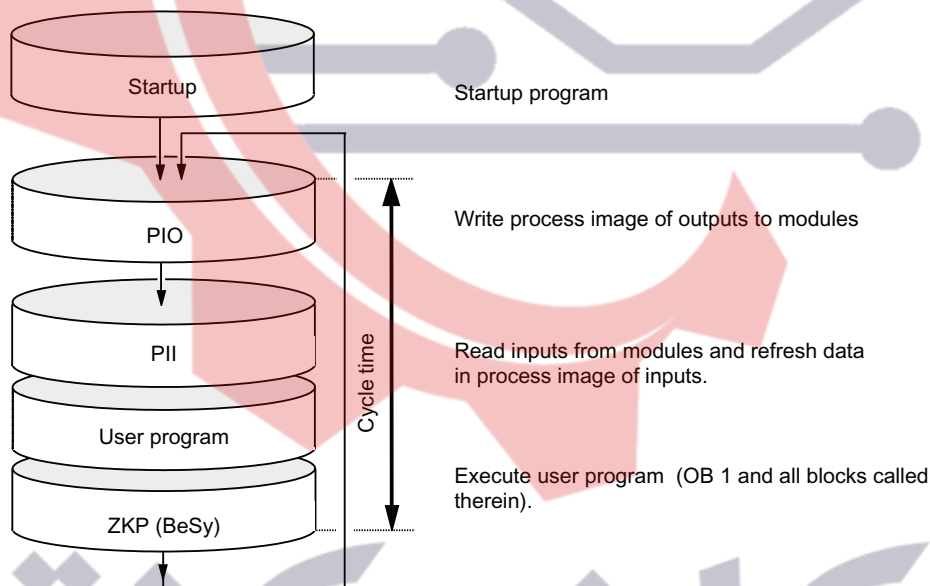

Configurable process image of the CPUs

STEP 7 lets you define a user-specific size of the process image of the inputs/outputs for the following CPUs.

CPU	Firmware
CPU 312	V3.0 or higher
CPU 312C	V3.3 or higher
CPU 313C	V3.3 or higher
CPU 313C-2 DP	V3.3 or higher
CPU 313C-2 PtP	V3.3 or higher
CPU 314	V3.0 or higher
CPU 314C-2 DP	V3.3 or higher
CPU 314C-2 PtP	V3.3 or higher
CPU 314C-2 PN/DP	V3.3 or higher
CPU 315-2 DP	V3.0 or higher
CPU 315-2 PN/DP	V2.5 or higher
CPU 317-2 DP	V2.5 or higher
CPU 317-2 PN/DP	V2.3 or higher
CPU 319-3 PN/DP	V2.4 or higher

For information on the size of the process image of your CPU please refer to the technical specifications.

ماکان کنترول

Please observe the following::

Note

Currently, the variable setting of the process image only affects its update at the cycle control point. This means that the process input image is updated up to the set PII size with the corresponding values of the input modules existing within this address area, or the values of the process output image up to the set POI limit are written to the output modules existing within this address area.

This set size of the process image is ignored with respect to STEP 7 commands used to access the process image (e.g.

A I100.0, L IW200, = Q20.0, T QD150, or also corresponding indirect addressing commands).

These commands output up to the maximum size of the process image, however they do not output any synchronous access errors (see technical specifications for size). Instead, they only access the permanently existing internal memory area of the process image. The same applies for the use of actual parameters of block call commands from the I/O area (area of the process image).

Particularly if these process image limits were changed, you should check to which extent your user program continues to access the process image in the area between the set and the maximum process image size. If access to this area continues, this may mean that changing inputs at the I/O module are no longer detected in the user program or that outputs actually are not written to the output module and no alarm is generated.

You should also note that certain CPs may only be addressed outside of the process image.

ماکان کنترول

Local data

Local data store the following:

- The temporary variables of code blocks
- The start information of the organization blocks
- Transfer parameters
- Intermediate results

Temporary variables

When you create blocks, you can declare temporary variables (TEMP) which are only available during processing of the block and are then overwritten. These local data have a fixed length in each OB. Local data must be initialized prior to the first read access. Furthermore, each organization block requires 20 bytes of local data for its start information.

The CPU is equipped with a memory for storing temporary variables (local data) of blocks which are being processed. The size of this memory area depends on the CPU. It is distributed among the priority classes in partitions of equal size. Each priority class has its own local data area.

CAUTION

All temporary variables (TEMP) of an OB and its subordinate blocks are stored in local data. If you use complex nesting levels for block processing, this may cause an overflow of the local data area.

The CPUs will change to STOP mode if you exceed the permissible size of local data for a priority class.

Make allowances for local data required for synchronous error OBs. This is assigned to the respective triggering priority class.

See also

Retentivity of load memory, system memory, and main memory (Page 150)

ماکان کنترول

5.1.5 Properties of the SIMATIC Micro Memory Card

The SIMATIC Micro Memory Card as memory module for the CPU

The memory module used on your CPU is a SIMATIC Micro Memory Card. You can use MMCs as load memory or as portable data carrier.

Note

The SIMATIC Micro Memory Card must be inserted in the CPU to permit operation.

What is stored on the SIMATIC Micro Memory Card?

The following data can be stored on the SIMATIC Micro Memory Card:

- User program, i.e. all blocks (OBs, FCs, FCs, DBs) and system data
- Archives and recipes
- Configuration data (STEP 7 projects)
- Data for operating system update and backup

Note

You can either store user and configuration data or the operating system on the SIMATIC Micro Memory Card.

Properties of a SIMATIC Micro Memory Card

The SIMATIC Micro Memory Card ensures maintenance-free operation and retentivity for these CPUs.

⚠ CAUTION

Data on a SIMATIC Micro Memory Card can be corrupted if you remove the card while it is being accessed for writing. In this case, you may have to delete the SIMATIC Micro Memory Card on your PG, or format the card in the CPU. Never remove a SIMATIC Micro Memory Card in RUN mode. Always remove it when power is off, or when the CPU is in STOP state, and when the PG is not writing to the card. When the CPU is in STOP mode and you cannot not determine whether or not a PG is writing to the card (e.g. load/delete block), disconnect the communication lines.

SIMATIC Micro Memory Card copy protection

Your SIMATIC Micro Memory Card has an internal serial number that implements an MMC copy protection on the user level. You can read this serial number from the SSL partial list 011C_H index 8 using SFC 51 RDSYSST. Program a STOP command in a know-how-protected block, for example, if the reference and actual serial number of your SIMATIC Micro Memory Card are not the same

Service life of a SIMATIC Micro Memory Card

The service life of a SIMATIC Micro Memory Card depends mainly on the following factors:

1. The number of delete or programming operations
2. External influences such as ambient temperature

At ambient temperatures up to 60 °C, a maximum of 100,000 delete/write operations can be performed on a SIMATIC Micro Memory Card.

CAUTION

To prevent loss of data, do not exceed the maximum number of delete/write operations.

Reference

Additional information:

- on the *SSL partial list* can be found in the *CPU 31xC and CPU 31x instruction list*, or in the Reference Manual *System Software S7-300/400 System and Standard Functions*
- on resetting the CPU can be found in the *Operating Instructions CPU 31xC and CPU31x, Commissioning, Commissioning Modules, CPU Memory Reset by means of Mode Selector*

See also

Operator controls and indicators: CPU 313C-2 DP (Page 30)

Operator controls and indicators: CPU 312 and CPU 314 (Page 45)

Operator controls and indicators: CPU 315-2 DP and CPU 317-2 DP (Page 47)

Operator controls and indicators: CPU 315-2 PN/DP and CPU 317-2 PN/DP (Page 50)

Operator controls and indicators: CPU 319-3 PN/DP (Page 52)

5.2 Memory functions

5.2.1 General: Memory functions

Memory functions

Memory functions are used to generate, modify or delete entire user programs or specific blocks. You can also ensure that your project data is retained by archiving it. If you created a new user program, use a PG/PC to download the complete program to the SIMATIC Micro Memory Card

5.2.2 Download of the user program to the SIMATIC Micro Memory Card in the CPU

Load user program

The entire user program is downloaded by means of the PG/PC to the CPU via the SIMATIC Micro Memory Card. The previous content of the Micro Memory Card is deleted in the process. Blocks use the load memory area as specified under "Load memory requirements" in "General block properties".

The figure shows the load and main memory of the CPU:

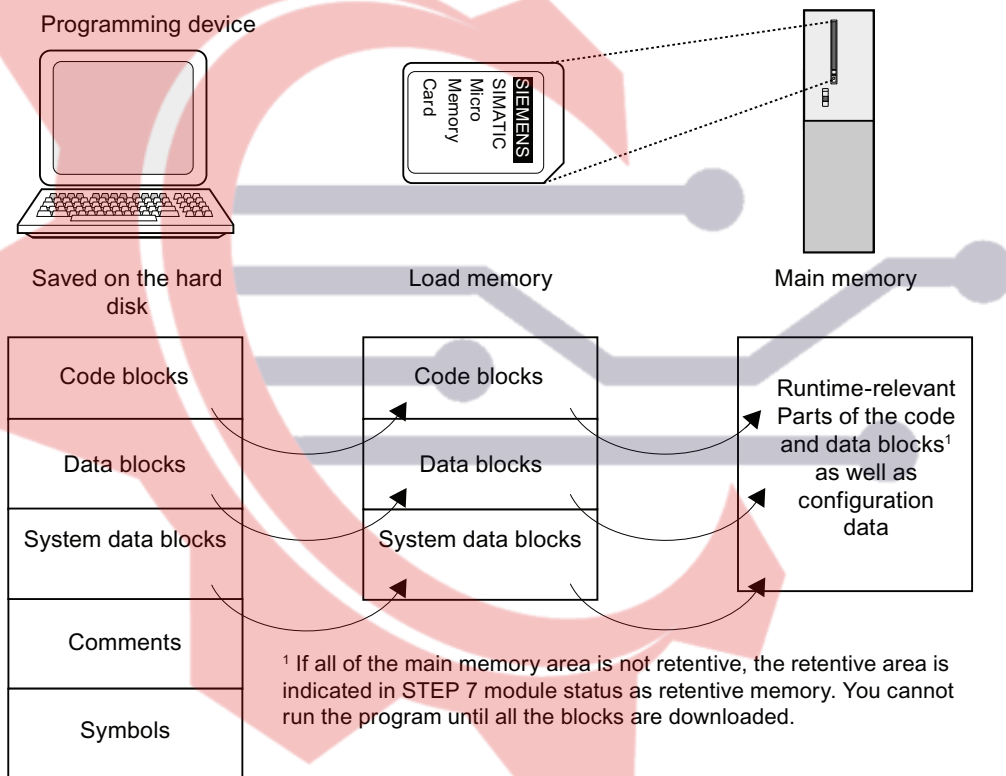

Note

This function is only permitted when the CPU is in STOP mode. The load memory is empty if the load operation could not be completed due to power loss or impermissible blocks.

5.2.3 Handling with blocks

5.2.3.1 Encryption of blocks

Important notes

Note**Supported blocks**

S7-Block Privacy can only be used to encrypt function blocks (FBs) and functions (FCs).

Once encrypted, the blocks can no longer be edited or monitored in STEP 7. The encryption also prevents execution of all test and commissioning functions, e.g. block status, or breakpoints.

Requirements

You can download encrypted blocks to the following CPUs: CPU31x V3.2.1 or higher

The "S7-Block Privacy" add-on packages supplied with STEP 7 must be installed. This is the only tool that you can use for strong encryption of the blocks.

General procedure

To encrypt the blocks, proceed as follows:

1. In STEP 7, right-click the block container and select "Block Privacy ...".
2. The S7BLP tool is launched.
3. Select the block (multiple selection is possible).
4. Right-click the block to be encoded and select "Encrypt Block...". The "Encrypt Block" dialog opens.
5. Select whether to include decompilation data in the encryption.

Note

All attempts to decompile the block will fail if you deactivate the check box!

6. Enter a key string with a length of at least 12 characters in both fields. Make sure you keep the key in a safe place. Click "OK" to launch the encryption.

Result: The block is encrypted. The following icons identify this status:



Decompilable encrypted block



Encrypted block that cannot be decompiled

Note

Command execution time

Usually, the command execution time is prolonged because encrypted blocks cannot be processed in fully optimized state. The final cycle time can only be determined with encrypted blocks.

Note

Prolonged runtimes during POWER ON/CPU memory reset/download

The CPU startup time, the time required for CPU memory reset, and the block download time can be prolonged significantly.

Additional information

For more information, refer to the STEP 7 Online Help, "S7-Block Privacy" section.

5.2.3.2 Reloading or transferring blocks

There are two ways to reload or overwrite user blocks:

- **Reloading blocks:** You have already created a user program and downloaded it to the SIMATIC Micro Memory Card in the CPU. You then want to add new blocks to the user program. In this case you do not need to download the entire user program to the SIMATIC Micro Memory Card again. Instead you only need to download the new blocks to the SIMATIC Micro Memory Card (this reduces the download times for highly complex programs).
- **Overwrite:** In this case, you make changes to blocks of your user program. In the next step you then overwrite the user program or only the changed blocks to the SIMATIC Micro Memory Card using the PG/PC.

 **WARNING**

When transferring blocks/a user program, all data stored under the same name on the SIMATIC Micro Memory Card is overwritten.

After loading runtime-relevant blocks, their content is transferred to the main memory and activated.

5.2.3.3 Uploading blocks

Uploading blocks

Unlike download operations, an upload operation is the transfer of specific blocks or a complete user program from the CPU to the PG/PC. The block content is here identical with that of the last download to the CPU. Runtime-relevant DBs are an exception, because their actual values are transferred. An upload of blocks or of the user program from the CPU in STEP 7 does not influence the assignment of CPU memory space.

5.2.3.4 Deleting blocks

Deleting blocks

When you delete a block, it is deleted from the load memory. In STEP 7, you can also delete blocks in the user program (DBs also with SFC 23 "DEL_DB"). Main memory used by this block is released.

5.2.3.5 Compressing blocks

Compressing blocks

When blocks are compressed, gaps between memory objects in the load memory/main memory as a result of load/delete operations are eliminated. The free memory space is made available as one block. Compressing is possible when the CPU is in RUN or in STOP mode.

5.2.3.6 Promming (RAM to ROM)

Promming (RAM to ROM)

Promming means that the actual values of the data blocks are transferred from the main memory to the load memory as new initial values of the DBs.

Note

This function is only permitted when the CPU is in STOP mode. The load memory will be empty if the function cannot be completed due to a power failure.

5.2.4 Memory reset and restart

Memory reset

After the insertion/removal of a Micro Memory Card, a memory reset restores defined conditions to permit a CPU restart (warm restart). A memory reset restructures the CPU's memory management. All blocks in the load memory are retained. All runtime-relevant blocks are transferred once again from the load memory to the main memory, in particular to initialize the data blocks in the main memory (restore initial values).

Restart (warm restart)

- All retentive DBs retain their actual value (non-retentive DBs are also supported by CPUs with firmware \geq V2.0.12. Non-retentive DBs receive their initial values).
- The values of all retentive M, C, T are retained.
- All non-retentive user data is initialized:
 - M, C, T, I, O with "0"
- All execution levels are initialized.
- The process images are deleted.

Reference

Also refer to *Memory reset using the CPU's mode selector* in the section *Commissioning* in the *CPU 31xC and CPU 31x Operating Instructions*.

ماکان کنترول

5.2.5 Recipes

Introduction

A recipe represents a collection of user data. You can implement a simple recipe concept using non-runtime-relevant DBs. In this case, the recipes should have the same structure (length). One DB should exist per recipe.

Processing sequence

Recipe is to be stored in the load memory:

- The various data records of recipes are created as non-runtime-relevant DBs in STEP 7 and then downloaded to the CPU. Therefore, recipes only occupy load memory space and no main memory space.

Working with recipe data:

- With SFC83 "READ_DBL", the user programs reads the data record of the current recipe from the DB in the load memory to a runtime-relevant DB in the main memory. As a result, the main memory only has to accommodate the data of one record. The user program can now access data of the current recipe. The figure below shows how to handle recipe data:

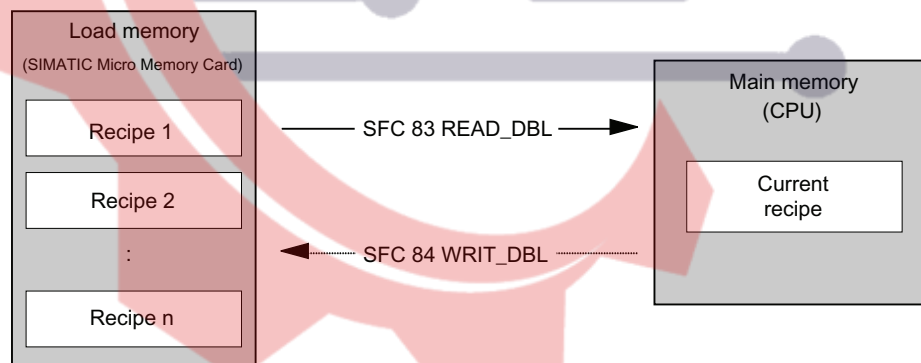

ماکان کنترول

Saving a modified recipe:

- With SFC 84 "WRIT_DBL", the user program can write new or modified recipe data records generated during program execution to the load memory. This data written to the load memory is portable and is retained in case of a memory reset. You can backup modified data records (recipes) on the PG/PC by uploading and saving them as a single block.

Note

The active system functions SFC 82 to 84 (active access to the SIMATIC Micro Memory Card) have a strong influence on PG functions (e.g. block status, variable status, load, upload, open block). This typically reduces performance (compared to passive system functions) by the factor 10.

Note

To prevent loss of data, do not exceed the maximum number of delete/write operations. Also refer to the SIMATIC Micro Memory Card (MMC) section in the "Structure and Connections of a CPU" chapter.

 **CAUTION**

Data on a SIMATIC Micro Memory Card can be corrupted if you remove the card while it is being accessed for writing. In this case, you may have to delete the SIMATIC Micro Memory Card on your PG, or format the card in the CPU. Never remove a SIMATIC Micro Memory Card in RUN mode. Always remove it when power is off, or when the CPU is in STOP state, and when the PG is not writing to the card. When the CPU is in STOP mode and you cannot not determine whether or not a PG is writing to the card (e.g. load/delete block), disconnect the communication lines.

ماکان کنترول

5.2.6 Measured value log files

Introduction

Measured values are generated when the CPU executes the user program. These values are to be logged and analyzed.

Processing sequence

Acquisition of measured values:

- The CPU writes all measured values to a DB (for alternating backup mode in several DBs) which is located in main memory.

Measured value logging:

- Before the data volume can exceed the main memory capacity, you can call SFC 84 "WRIT_DBL" in the user program to swap measured values from the DB to load memory. The figure below shows how to handle measured value log files:

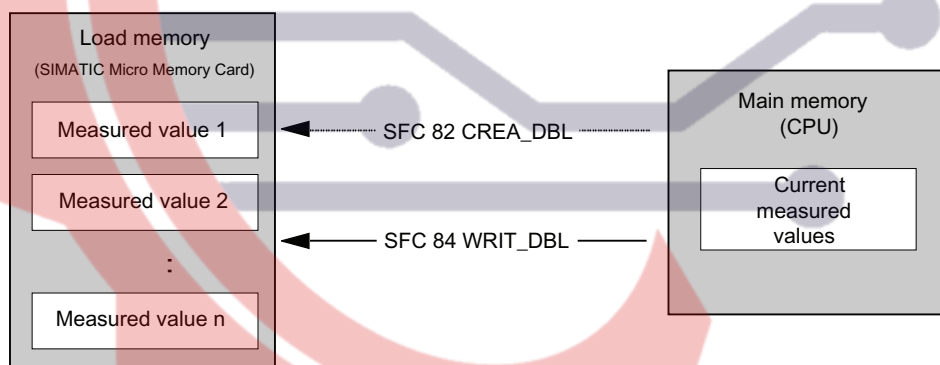

- You can call SFC 82 "CREA_DBL" in the user program to generate new (additional) non-runtime-relevant DBs in load memory which do not require main memory space.

ماکان کنترول

Reference

For detailed information on SFC 82, refer to the *System Software for S7-300/400, System and Standard Functions Reference Manual*, or directly to the STEP 7 Online Help.

Note

SFC 82 is terminated and an error message is generated if a DB already exists under the same number in load memory and/or main memory.

This data written to the load memory is portable and is retained in case of a memory reset.

Evaluation of measured values:

- Measured value DBs saved to the load memory can be uploaded and evaluated by other communication peers (e.g. PG, PC, etc.).

Note

The active system functions SFC 82 to 84 (active access to the SIMATIC Micro Memory Card) have a strong influence on PG functions (e.g. block status, variable status, load, upload, open block). This typically reduces performance (compared to passive system functions) by the factor 10.

Note

For CPUs with firmware V2.0.12 or higher, you can also generate non-retentive DBs using SFC 82 (parameter ATTRIB → NON_RETAIN bit.)

Note

To prevent loss of data, do not exceed the maximum number of delete/write operations. For additional information, refer to the technical specifications of the SIMATIC Micro Memory Card in the "General Technical Specifications" of your CPU.

CAUTION

Data on a SIMATIC Micro Memory Card can be corrupted if you remove the card while it is being accessed for writing. In this case, you may have to delete the SIMATIC Micro Memory Card on your PG, or format the card in the CPU. Never remove a SIMATIC Micro Memory Card in RUN mode. Always remove it when power is off, or when the CPU is in STOP state, and when the PG is not writing to the card. When the CPU is in STOP mode and you cannot not determine whether or not a PG is writing to the card (e.g. load/delete block), disconnect the communication lines.

5.2.7 Backup of project data to SIMATIC Micro Memory Card

Functional principles

Using the **Save project to Memory Card** and **Fetch project from Memory Card** functions, you can save all project data to a SIMATIC Micro Memory Card, and retrieve these at a later time. For this operation, the SIMATIC Micro Memory Card can be located in a CPU or in the MMC programming unit of a PG or PC.

Project data is compressed before it is saved to a SIMATIC Micro Memory Card, and uncompressed on retrieval.

Note

In addition to project data, you may also have to store your user data on the MMC. You should therefore select a SIMATIC Micro Memory Card with sufficient memory space.

A message warns you of insufficient memory capacity on your SIMATIC Micro Memory Card.

The volume of project data to be saved corresponds with the size of the project's archive file.

Note

For technical reasons, you can only transfer the entire contents (user program and project data) using the **Save project to memory card** function.

ماکان کنترول



ماکان کنترول

Cycle and response times

6.1 Overview

Overview

This section contains detailed information about the following topics:

- Cycle time
- Response time
- Interrupt response time
- Sample calculations

Reference: Cycle time

You can read out the cycle time of your user program using the PG. For additional information, refer to the *STEP 7 Online Help* or to the *Configuring Hardware and Connections in STEP 7* manual and in the *Programming with STEP 7* manual.

Reference: Execution time

Can be found in the *S7-300 Instruction List for S7-300 CPUs and IMs with integrated CPU*. This tabular list contains the execution times for all:

- STEP 7 instructions that the relevant CPU can execute
- The SFCs/SFBs integrated in the CPUs
- The IEC functions which can be called in STEP 7.

ماکان کنترول

6.2 Cycle time

6.2.1 Overview: Cycle time

Introduction

This section explains what we mean by the term "cycle time", what it consists of, and how you can calculate it.

Definition of cycle time

The cycle time represents the time that an operating system needs to execute a program, that is, one OB 1 cycle, including all program sections and system activities interrupting this cycle.

This time is monitored.

Time slice model

Cyclic program processing, and therefore also user program processing, is based on time slices. To clarify these processes, let us assume that every time slice has a length of precisely 1 ms.

Process image

During cyclic program processing, the CPU requires a consistent image of the process signals. To ensure this, the process signals are read/written prior to program execution. Subsequently, during program processing the CPU does not access the signal modules directly when addressing the input (I) and output (O) address areas, but rather it accesses the CPU's system memory area containing the I/O process image.

ماکان کنترول

Sequence of cyclic program processing

The table and figure below show the phases in cyclic program processing.

Table 6- 1 Cyclic program processing

Phase	Sequence
1	The operating system initiates cycle time monitoring.
2	The CPU copies the values from the process output images to the output modules.
3	The CPU reads the status of the inputs at the input modules and updates the process input image.
4	The CPU processes the user program in time slices and executes the instructions specified in the program.
5	At the end of a cycle, the operating system executes pending tasks, e.g. loading and deleting of blocks.
6	The CPU then returns to the start of the cycle, and restarts cycle time monitoring.

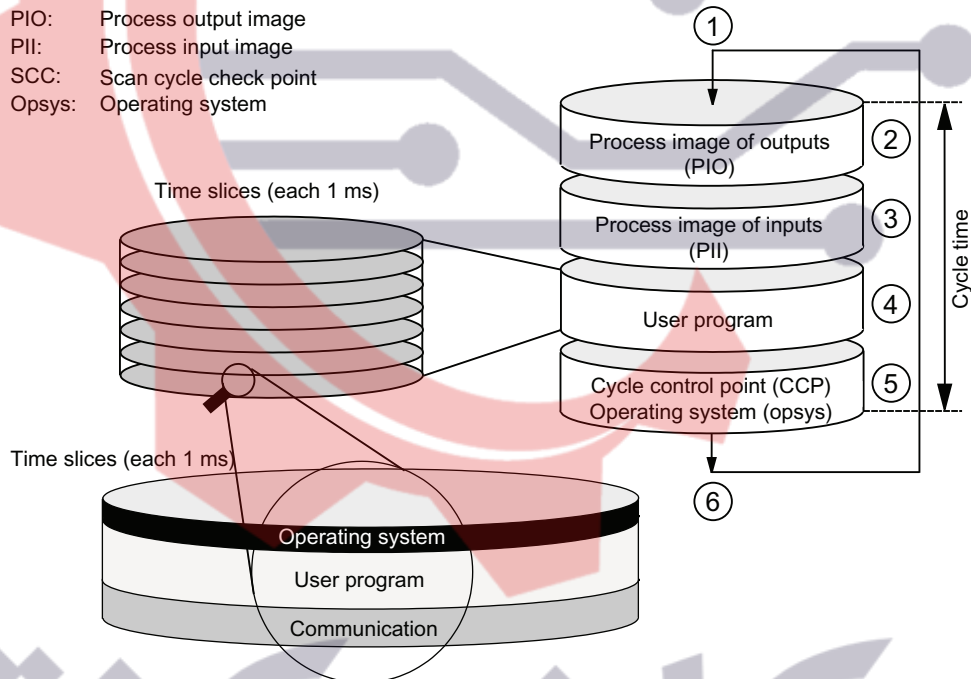

With the S7-300 CPUs, the data are accessed with an OP/TP (operator control and monitoring functions) exclusively at the cycle control point (for data consistency, see Technical Specifications). Program execution is not interrupted by the operator control and monitoring functions.

6.2.2 Calculating the cycle time

Introduction

The cycle time is derived from the sum of the following influencing factors.

Extending the cycle time

Always make allowances for the extension of the cycle time of a user program due to:

- Time-based interrupt processing
- Hardware interrupt processing
- Diagnostics and error processing
- Processing of synchronous cycle interrupts
- Communication with programming devices (PGs), Operator Panels (OPs), and via connected CPs (e.g. Ethernet, PROFIBUS DP)
- Test and startup functions such as status/controlling of variables or block status.
- Transfer and deletion of blocks, compressing of the user program memory
- Write/read access to the Micro Memory Card from the user program using SFC 82 to SFC 84
- S7 communication via integrated PROFINET interface
- PROFINET CBA communication via the PROFINET interface (system load, SFC call, updating at the cycle control point)
- PROFINET IO communication via the PROFINET interface (system load)
- Activating "prioritized OCM communication" in the properties dialog of the CPU

ماکان کنترول

Influencing factors

The table below shows the factors influencing the cycle time.

Table 6- 2 Factors influencing cycle time

Factors	Comment
Transfer time for the process image output (PIQ) and the process image of the inputs (PII)	... See table "Data for calculating the typical transfer time for the process image"
User program execution time	... Is calculated from the execution times of the different instructions, see <i>S7-300 instruction list</i>
Operating system execution time at cycle control point	... See table "Typical operating system execution times at the cycle control point"
Extension of cycle time due to communication load	... You configure the maximum permitted communication load on the cycle as a percentage in STEP 7, see the <i>Programming with STEP 7</i> manual.
Load on cycle times due to interrupts	Interrupt requests can always stop user program execution. See table "Typical extended cycle time due to nested interrupts".

ماکان کنترول

Process image update

The table below shows the time a CPU requires to update the process image (process image transfer time). The times specified might be prolonged as a result of interrupts or CPU communication. The transfer time for the process image update is calculated as follows:

Table 6- 3 Formula for calculating the typical transfer time for the process image (PI):

Base load (value from line K)	+ Number of bytes in PI in module rack 0 x (value from line A) + number of bytes in PI in module racks 1 to 3 x (value from line B) + Number of words in PI via DP x (value from line D) + Number of words in PI via PROFINET x (value from line P) = Transfer time for the process image
----------------------------------	--

Table 6- 4 CPU 31xC: Data for calculating the process image (PI) transfer time

Const.	Components	CPU						
		312C	313C	313C-2 DP	313C-2 PtP	314C-2 PtP	314C-2 DP	314C-2 PN/DP
K	Base load	170 µs	150 µs	150 µs		150 µs		
A	Per byte in rack 0	35 µs		35 µs		35 µs		
B	Per byte in racks 1 to 3	-	35 µs*	35 µs*		35 µs*		
D (DP only)	Per word in the DP area for the integrated DP interface	--		0.5 µs	-	-	0.5 µs	
P (PN only)	Per word in the PROFINET area for the integrated PROFINET interface	-		-		-		0.5 µs

* +40 µs je per rack

Table 6- 5 CPU 31x: Data for calculating the process image (PI) transfer time

Const.	Components	CPU				
		312	314	315	317	319
K	Base load	150 µs	120 µs	100 µs	70 µs	40 µs
A	Per byte in rack 0	20 µs			15 µs	
B	Per byte in racks 1 to 3	-	30 µs*		25 µs*	22 µs*
D (DP only)	Per word in the DP area for the integrated DP interface	-		0.5 µs		
P (PROFINET only)	Per word in the PROFINET area for the integrated PROFINET interface	-		0.5 µs		

* +40 µs je per rack

Extending the user program processing time

In addition to actually working through the user program, your CPU's operating system also runs a number of processes in parallel, such as timer management for the core operating system. These processes extend the processing time of the user program by up to 10 %.

Operating system processing time at the cycle control point

The table below shows the operating system processing times at the cycle control point of the CPUs. These times apply without:

- Testing and commissioning routines, e.g. status/controlling of variables or block status functions
- Transfer and deletion of blocks, compressing user program memory
- Communication
- Writing, reading of the SIMATIC Micro Memory Card with SFC 82 to 84

Table 6- 6 Typical operating system processing time at the cycle control point (CCP)

CPU	Cycle control in the cycle control point
312, 312C	250 µs
313C, 313C-2	180 µs
314, 314C-2, 314C-2 PN/DP	150 µs
315	140 µs
317	120 µs
319	90 µs

Extension of the cycle time as a result of nested interrupts

Enabled interrupts also extend cycle time. Details are found in the table below.

Table 6- 7 Typical extended cycle time due to nested interrupts

CPU	Interrupt type				
	Hardware interrupt	Diagnostic interrupt	Time-of-day interrupt	Time-delay interrupt	Cyclic interrupt
312C	300 µs	300 µs	400 µs	250 µs	250 µs
313C	250 µs	250 µs	300 µs	220 µs	200 µs
313C-2	250 µs	250 µs	300 µs	220 µs	200 µs
314C-2	250 µs	250 µs	300 µs	200 µs	170 µs
312	300 µs	300 µs	400 µs	200 µs	200 µs
314	250 µs	250 µs	300 µs	170 µs	150 µs
315	200 µs	200 µs	200 µs	150 µs	140 µs
317	160 µs	180 µs	150 µs	80 µs	80 µs
319	120 µs	100 µs	100 µs	50 µs	40 µs

The program runtime at interrupt level must be added to this time extension.

The corresponding times are added together if the program contains nested interrupts.

Extension of the cycle time due to errors

Table 6- 8 Typical cycle time extension as a result of errors

CPU	Type of error: Programming error / I/O access error
312C	220 μs
313C	180 μs
313C-2	180 μs
314C-2	150 μs
312	220 μs
314	150 μs
315	100 μs
317	60 μs
319	20 μs

You have to add the program execution time of the interrupt OB to this increase. The times required for multiple nested interrupt/error organization blocks are added accordingly.

6.2.3 Different cycle times

Overview

The cycle time (T_{cyc}) length is not the same in every cycle. The figure below shows different cycle times T_{cyc1} and T_{cyc2} . The cycle time T_{cyc2} is longer than T_{cyc1} , because the cyclically executed OB 1 is interrupted by a time-of-day interrupt OB (here: OB 10).

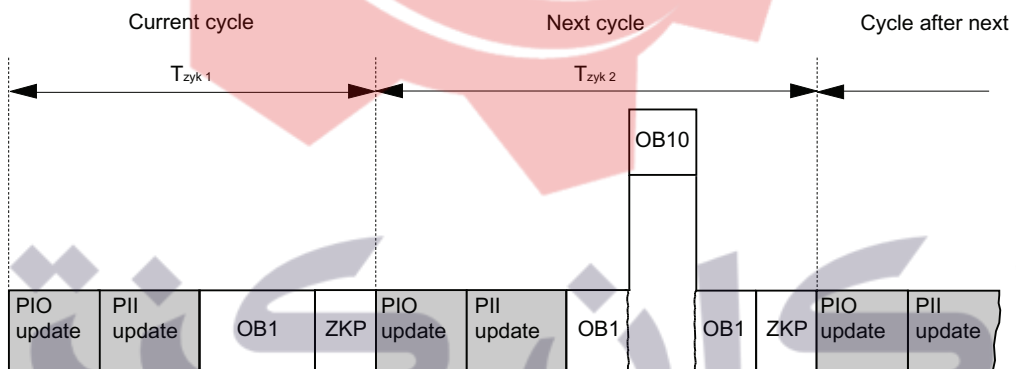

Block processing times may fluctuate

The execution times of blocks (e.g. OB 1) can vary for different reasons. They vary because of:

- Conditional instructions
- Conditional block calls
- Different program paths
- Loops, etc.

These influences lead to cycle times that differ in length.

Scan cycle monitoring time

The time is monitored for program execution in OB 1. This monitoring is performed using the so-called scan cycle monitoring time. By default, the monitoring time in STEP 7 is preset to 150 ms. You can use the CPU's parameter settings to modify this value in a range from 1 ms to 6 s.

If the processing of the main program exceeds the set scan cycle monitoring time, the CPU calls the OB 80 (error interrupt). If OB 80 is not available, the CPU changes to STOP mode.

The scan cycle monitoring time includes the entire processing time of OB 1. This time also includes the processing times for higher priority classes, that interrupt the main program (in the current cycle). Communications processes by the operating system also extend the runtime of the main program.

ماکان کنترول

6.2.4 Communication load

Configured communication load for PG/OP communication, S7 communication and PROFINET CBA

The CPU operating system continuously provides a specified percentage of total CPU processing performance (time slice technology) for communication tasks. Processing performance not required for communication is made available to other processes.

In the hardware configuration you can specify a communication load value between 5% and 50%. The default value is 20%.

Maximum load generated by communication functions increases by approx. 10% (e.g. from 50% to 60%) if "prioritized OCM communication" is activated.

Cycle time prolongation depends on the load caused by communication processes and can fluctuate.

To calculate the factor that determines maximum extension of the cycle time, you can use the following formula:

- **Prioritized OCM communication disabled:**
 $100 / (100 - \text{configured communication load in } \%)$
- **Prioritized OCM communication enabled:**
 $100 / (100 - (\text{configured communication load in } \% + 10\%))$

Time slice (1 ms)

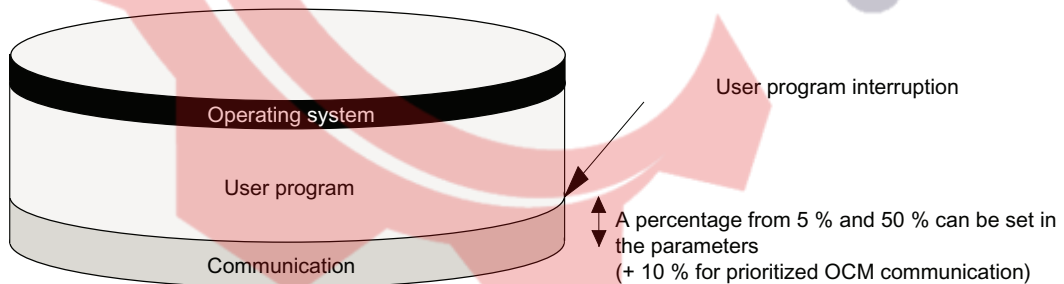

Example: 20% communication load

In your hardware configuration, you have specified a communication load of 20%. The calculated cycle time is 10 ms. Using the above formula, the cycle time is extended by the factor 1.25.

Example: 50% communication load

In your hardware configuration, you have specified a communication load of 50%. The calculated cycle time is 10 ms. Using the above formula, the cycle time is extended by the factor 2.

Dependency of actual cycle time on the communication load

The figure below describes the non-linear dependency of the actual cycle time on the communication load. In our example we have chosen a cycle time of 10 ms.

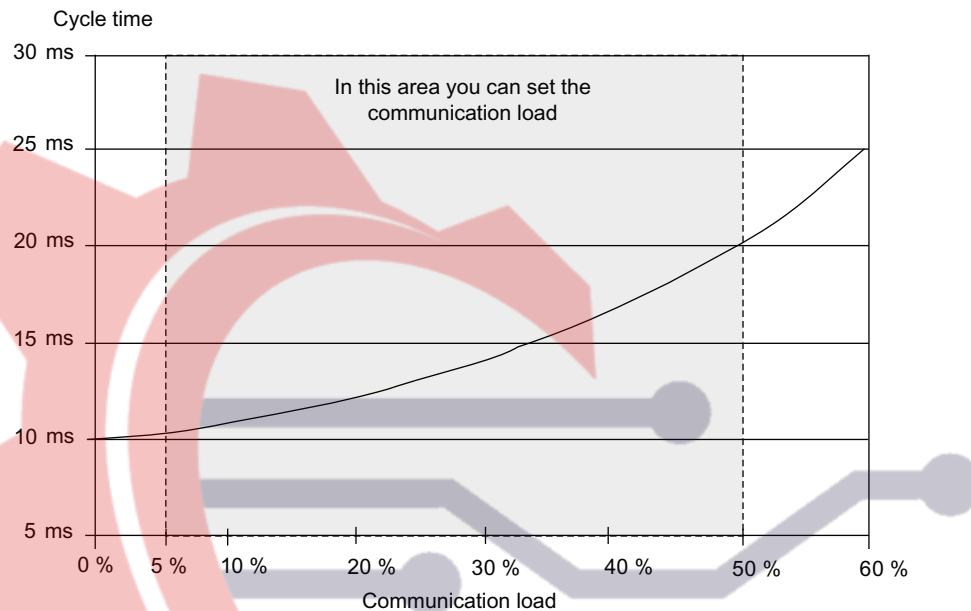

Influence on the actual cycle time

From the statistical viewpoint, asynchronous events such as interrupts occur more frequently within the OB 1 cycle when the cycle time is extended as a result of communication load. This further extends the OB 1 cycle. This extension depends on the number of events that occur per OB 1 cycle and the time required to process these events.

Note

Change the value of the "communication load" parameter to check runtime effects on the cycle time.

You must consider the communication load when setting the maximum cycle time, otherwise time errors may occur.

Tips

- Use the default setting whenever possible.
- Increase this value only if the CPU is used primarily for communication and if the user program is not time critical.
- In all other situations you should only reduce this value.

6.2.5 Cycle time extension as a result of test and commissioning functions

Runtimes

The runtimes of the testing and commissioning functions are operating system runtimes, so they are the same for every CPU. How the cycle time is extended as a result of active testing and commissioning functions is shown in the table below.

Table 6-9 Cycle time extension as a result of test and commissioning functions

Function	CPU 31x and CPU 31xC
Status variable	Negligible
Control variable	Negligible
Status block	Typ. 3 µs for each monitored line +3 x runtime of monitored block *
* The monitoring of larger blocks and the monitoring of loops can lead to a significant increase in the cycle time.	

Setting process and test mode through parameter assignment (for CPUs < V2.8)

For **process mode**, the maximum permissible cycle load due to communication is not only specified in "Cycle load due to communication". It must also be set via "Process mode ⇒ Maximum permitted increase of cycle time as a result of test functions". Thus, the parameterized time is monitored absolutely in process mode, and data acquisition is stopped if a timeout occurs. This is how STEP 7 stops data requests in loops before a loop ends, for example. When running in **test mode**, the complete loop is executed in every cycle. This can significantly increase cycle time.

Setting process and test mode in the LAD/FBD/STL editor (for CPUs ≥ V2.8)

With the CPUs ≥ V2.8, switching between process and test mode is carried out directly in the LAD/FBD/STL editor in the "Test/Mode" menu.

Loops in the test and process mode are handled differently in the Status block.

- **Process mode:** First loop iteration is displayed
- **Test mode:** Last loop iteration is displayed. Leads to a significant cycle time increase for many loop iterations.

In terms of function, there is also no difference between process mode and test mode.

Note

It is also possible to set breakpoints in test mode.

6.2.6 Cycle extension through Component Based Automation (CBA)

By default, the operating system of your CPU updates the PROFINET interface as well as the DP interconnections at the cycle control point. However, if you deactivated these automatic updates during configuration (e.g. to influence the time behavior of the CPU better), you must perform the update manually. This is done by calling the SFCs 112 to 114 at the appropriate times.

Reference

Information about the SFCs 112 to 114 is available in the *STEP 7 Online Help*.

Extending the OB1 cycle

The OB1 cycle is extended by

- Increasing the number of PROFINET CBA interconnections
- Increasing the number of remote peers
- Increasing the data volume
- Increasing the transfer frequency

Note

The use of CBA with cyclical PROFINET CBA interconnections requires the use of switches to maintain the specified performance. 100 Mbps full-duplex operation is mandatory with cyclical PROFINET CBA interconnections.

The following graphic shows the configuration that was used for the measurements.

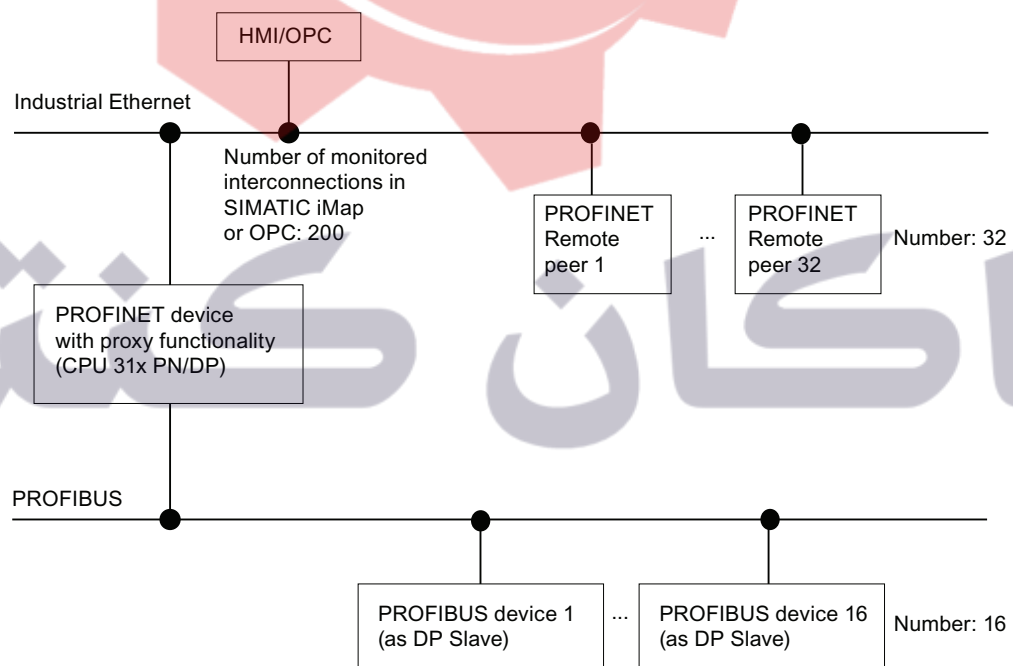

The above graphic shows incoming/outgoing remote connections	Number of connections for CPU 315, CPU 317 and CPU 314C-2 PN/DP	Quantity for CPU 319
Cyclic interconnection via Ethernet	200, scan cycle rate: every 10 ms	300, scan cycle rate: every 10 ms
Acyclic interconnection via Ethernet	100, scan cycle rate: every 500 ms	100, scan cycle rate: every 200 ms
Interconnections from the PROFINET device with proxy functionality to the PROFIBUS devices	16 x 4	16 x 4
Interconnections of PROFIBUS devices among each other	16 x 6	16 x 6

Additional marginal conditions

The maximum cycle load through communication is 20% in the measurement.

The following graphic shows that the OB 1 cycle is influenced by increasing the cyclic PROFINET CBA interconnections to remote peers on PROFINET:



ماکان کنترول

Additional cycle load of the OB1 cycle (CPU 314C-2 PN/DP) depending on number of cyclic CBA interconnections

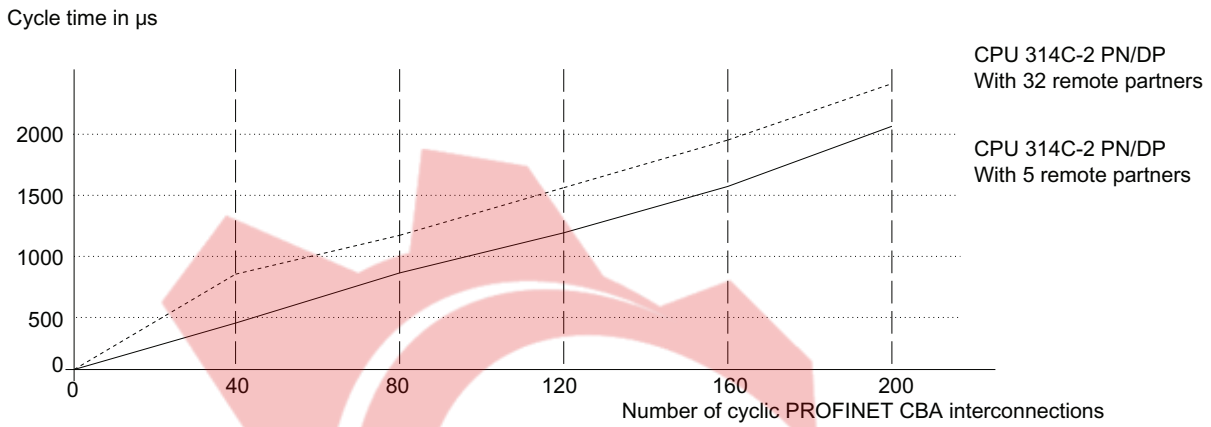

Additional cycle load of the OB1 cycle (CPU 315) depending on number of cyclic CBA interconnections

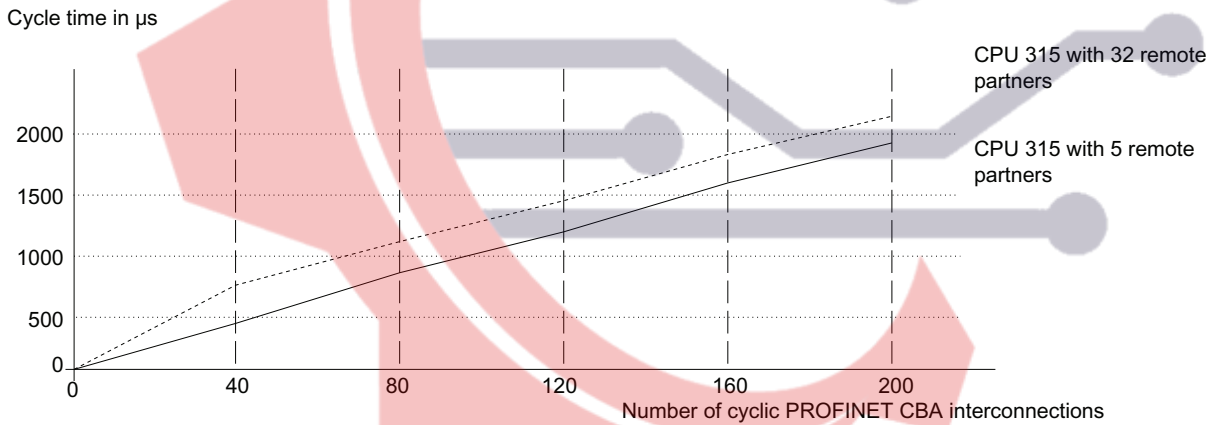

Additional cycle load of the OB1 cycle (CPU 317) depending on number of cyclic CBA interconnections

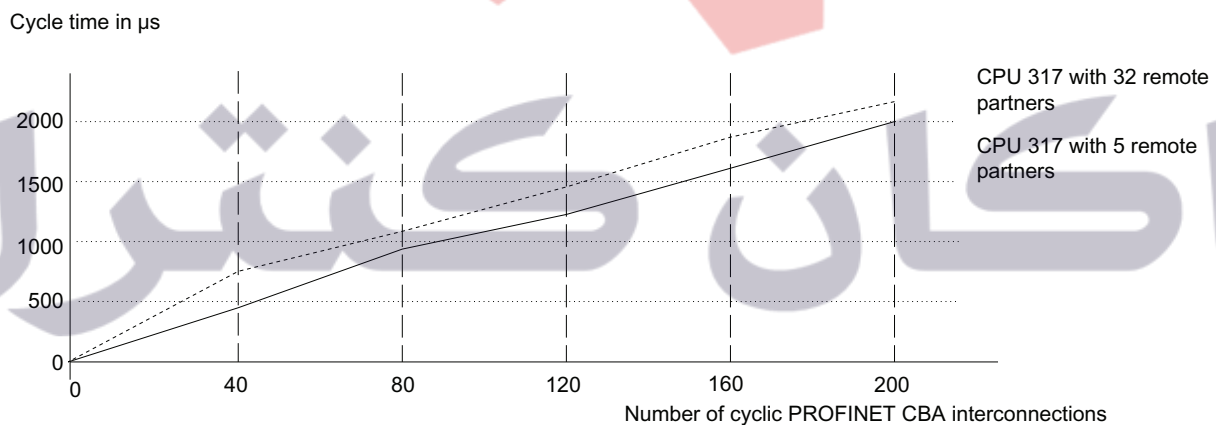

6.2 Cycle time

Additional cycle load of the OB1 cycle (CPU 319) depending on number of cyclic CBA interconnections

Cycle time in μs

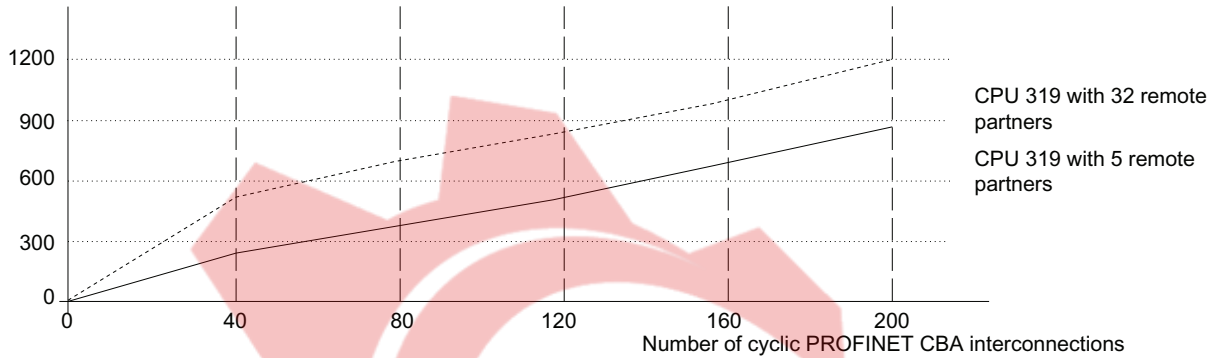

Base load through PROFIBUS devices

The 16 PROFIBUS devices with their interconnections among each other generate an additional base load of up to 1.0 ms.

Tips and notes

The upper graphic already includes the use of uniform values for the transfer frequency of all interconnections to a peer.

- The performance can drop by up to 50% if the values are distributed among different frequency levels.
- The use of data structures and arrays in an interconnection instead of many single interconnections with simple data structures increases the performance.

ماکان کنترول

6.3 Response time

6.3.1 Overview: Response time

Definition of response time

The response time is the time from detecting an input signal to changing the output signal associated with it.

Fluctuation range

The actual response time lies between the shortest and the longest response time. You must always assume the longest response time when configuring your system.

The shortest and longest response times are contemplated below to give you an idea of the fluctuation range of the response time.

Factors

The response time depends on the cycle time and the following factors:

- Delay of the inputs and outputs of signal modules or integrated I/Os.
- Additional update times for PROFINET IO
- Additional DP cycle times on PROFIBUS DP
- Execution in the user program

Delay of inputs/outputs

Make allowances for the following module-specific delay times:

- | | |
|---|--|
| <ul style="list-style-type: none"> • For digital inputs: | The ON-delay time |
| <ul style="list-style-type: none"> • For digital inputs with interrupt function: | The ON-delay time + module internal pre-processing time |
| <ul style="list-style-type: none"> • For digital outputs: | The delay times of the module are negligible |
| <ul style="list-style-type: none"> • For relay outputs: | Typical delay times of 10 ms to 20 ms. The delay of relay outputs also depends on the temperature and voltage. |
| <ul style="list-style-type: none"> • For analog inputs: | cycle time for analog input |
| <ul style="list-style-type: none"> • For analog outputs: | response time at analog outputs |

The delay times can be found in the technical specifications of the signal modules *S7-300 Automation System Module Data*.

Update times for PROFINET IO

If you configured your PROFINET IO system in STEP 7, STEP 7 calculates the update time for PROFINET IO. You can then view the PROFINET IO update time on your PG.

DP cycle times in the PROFIBUS DP network

If you configured your PROFIBUS DP master system in STEP 7, STEP 7 calculates the typical DP cycle time to be expected. You can then view the DP cycle time of your configuration on the PG.

The figure below gives you an overview of the DP cycle time. In this example, we assume that the data of each DP slave has an average length of 4 bytes.

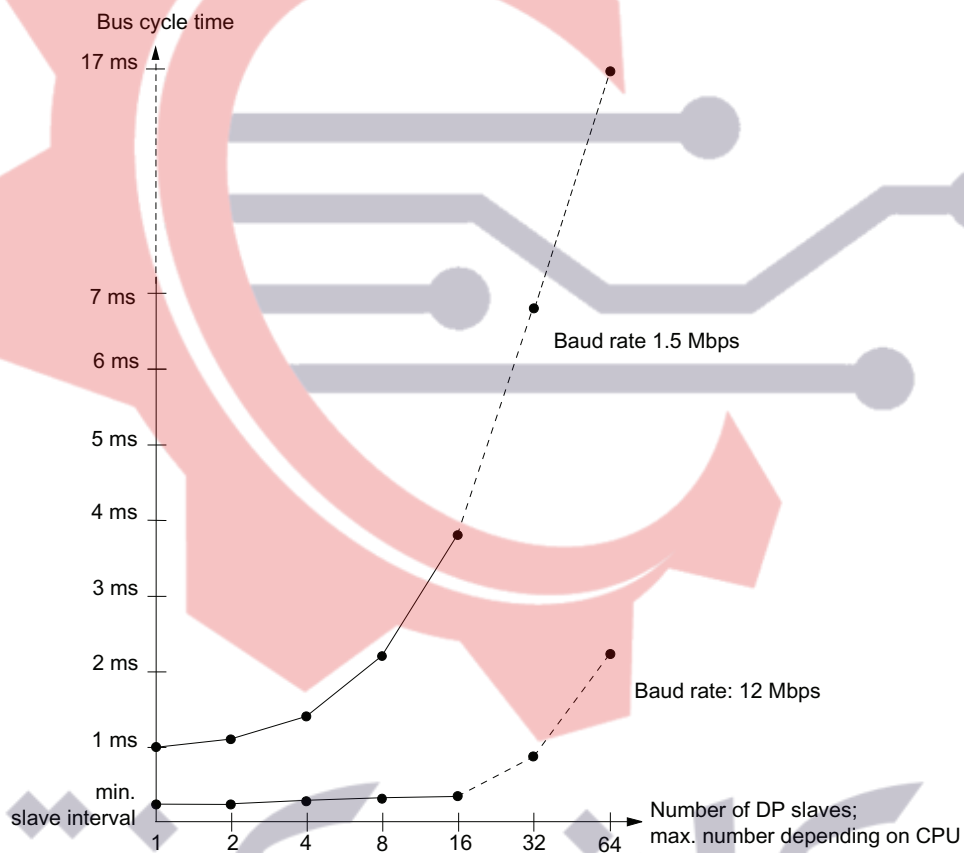

With multi-master operation on a PROFIBUS DP network, you must make allowances for the DP cycle time for each master. That is, you will have to calculate the times for each master separately and then add the results.

6.3.2 Shortest response time

Conditions for the shortest response time

The figure below shows the conditions under which the shortest response time is achieved.

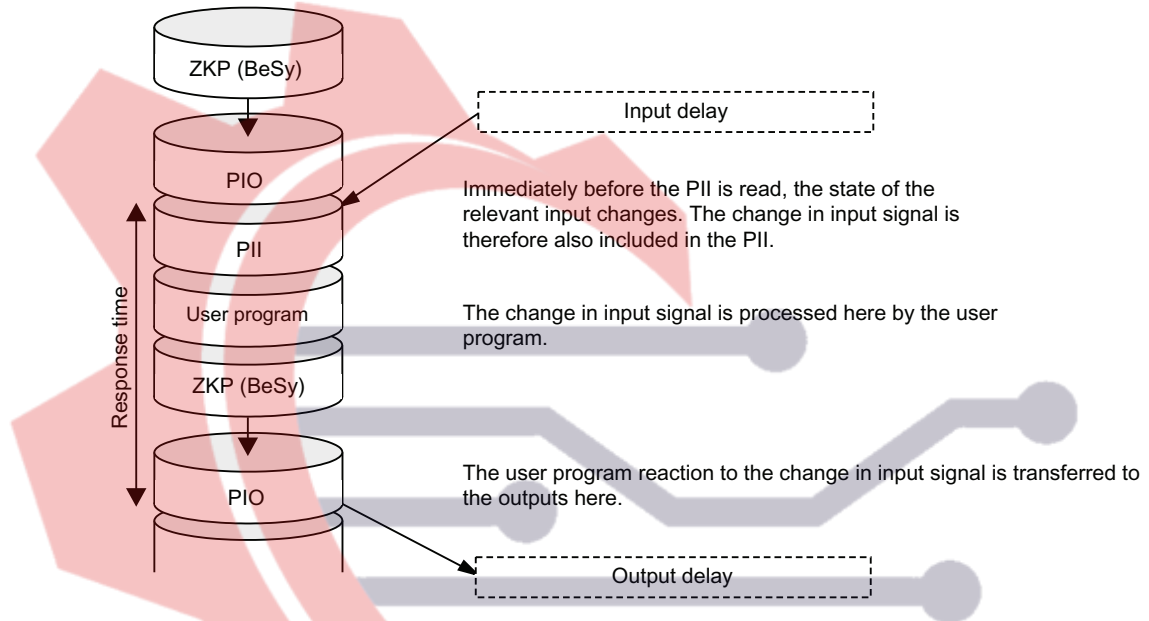

Calculation

The (shortest) response time is calculated as follows:

Table 6- 10 Formula: Shortest response time

	1 × process image transfer time for the inputs
+	1 × process image transfer time for the outputs
+	1 x program processing time
+	1 x operating system processing time at the SCCP
+	Delay of the inputs and outputs
=	Shortest response time

The result is equivalent to the sum of the cycle time plus the I/O delay times.

See also

Overview: Response time (Page 187)

6.3.3 Longest response time

Conditions for the longest response time

The figure below shows the conditions under which the longest response time is achieved.

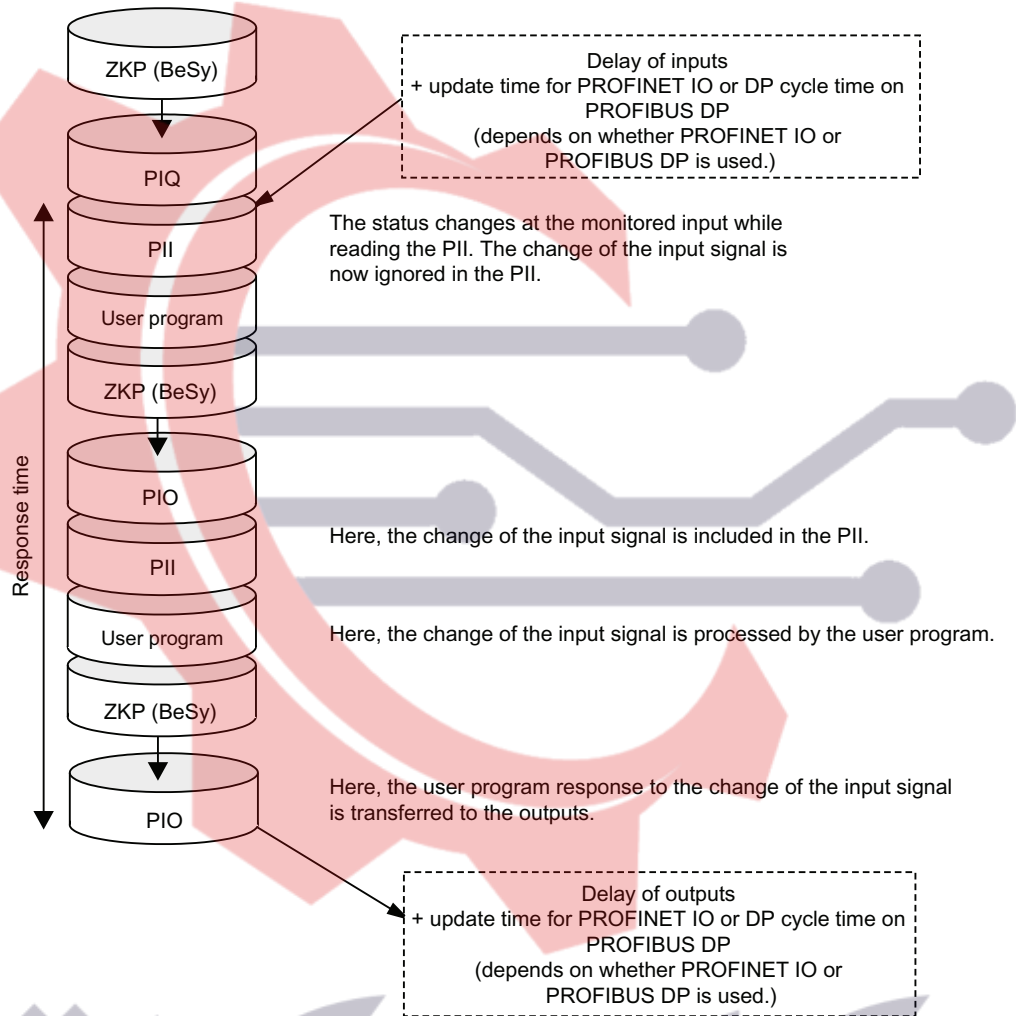

Calculation

The (longest) response time is calculated as follows:

Table 6- 11 Formula: Longest response time

	2 × process image transfer time for the inputs
+	2 × process image transfer time for the outputs
+	2 x program processing time
+	2 x operating system processing time
+	2 x PROFINET IO update time (only if PROFINET IO is used)
+	2 x DP cycle time on PROFIBUS DP (only if PROFIBUS DP is used.)
+	Delay of the inputs and outputs
=	Longest response time

Equivalent to the sum of 2 x the cycle time and I/O delay time plus 2 x the PROFINET IO update time or 2 x times the DP cycle time on PROFIBUS DP.

See also

Overview: Response time (Page 187)

6.3.4 Reducing the response time using I/O accesses

Reducing the response time

To achieve faster response times, use direct access to the I/O (e.g. L PEB, T PAW, ...).

Faster response times can be achieved using hardware interrupts.

See also

Shortest response time (Page 189)

Longest response time (Page 190)

6.4 Calculating method for calculating the cycle/response time

Introduction

This section gives you an overview of how to calculate the cycle/response time.

Cycle time

1. Determine the user program runtime with the help of the *instruction list*.
2. Add 10% to the value of the user program runtime.
3. Calculate and add the transfer time for the process image (refer to Chapter Calculating the cycle time (Page 174)). Corresponding guide values are found in the table *Data for calculating the process image transfer time*.
4. Add the processing time at the cycle control point. Corresponding guide values are found in the table *Operating system processing time at the cycle control point*.
5. Include in your calculation the extensions as a result of test and commissioning functions, as well as cyclic PROFINET interconnections. You can find these values in the table *Cycle time extension due to test and commissioning functions*.

The final result is the **cycle time**.

Cycle time extension due to interrupts and communication and the shortest/longest response time

1. Multiply the cycle time by the following factor:
 $100 / (100 - \text{configured communication load in \%})$
2. Use the instruction list to calculate the runtime of the program sections which process the interrupts. To do this, add the corresponding value from the table "Typical cycle time extension due to nested interrupts".
3. Multiply this value by the factor from step 1.
4. Add the value of the interrupt-processing program sequences to the theoretical cycle time, multiplied by the number of times that the interrupt will be triggered/probably will be triggered.

The result is an approximated **actual cycle time**. Note down the result.

Table 6- 12 Example of calculating the response time

Shortest response time	Longest response time
5. Now add the delays of the inputs and outputs.	5. Multiply the actual cycle time by factor 2.
	6. Now add the delays of the inputs/outputs, the DP cycle times on PROFIBUS-DP or the PROFINET IO update times.
6. The result you obtain is the shortest response time .	7. The result you obtain is the longest response time .

See also

Cycle extension through Component Based Automation (CBA) (Page 183)

6.5 Sample calculations for the cycle and response times**Example I**

You have set up an S7300 and equipped it with following modules in rack 0:

- a CPU 314C-2 PN/DP
- 2 digital input modules SM 321; DI 32 x DC 24 V (each with 4 bytes in the PI)
⇒ 8 bytes in the process image
- 2 digital output modules SM 322; DO 32 x DC 24 V/0,5 A (each with 4 bytes in the PI)
⇒ 8 bytes in the process image

User program

- According to the instruction list, the user program runtime is 5 ms.
- There is no active communication.

Calculating the cycle time

The cycle time for the example results from the following times:

- User program execution time:
5 ms plus user program processing time extension of 10% ⇒ 5.5 ms
- Process image transfer time (refer to Calculating the cycle time (Page 174)):
Process image of inputs: $150 \mu\text{s} + 8 \text{ bytes} \times 35 \mu\text{s} = \text{approx. } 0.43 \text{ ms}$
Process image of outputs: $150 \mu\text{s} + 8 \text{ bytes} \times 35 \mu\text{s} = \text{approx. } 0.43 \text{ ms}$
- Operating system runtime at cycle control point: 0.15 ms

Cycle time = 5.5 ms + 0.43 ms + 0.43 ms + 0.15 ms = 6.51 ms

Calculation of the actual cycle time

- There is no active communication.
- There is no interrupt processing.

Hence, the **actual cycle time** is 6.51 ms.

Calculating the longest response time

Longest response time:

$6.51 \text{ ms} \times 2 = 13.02 \text{ ms}$.

- The delay of the inputs and outputs is negligible.
- Since neither PROFIBUS DP nor PROFINET IO are being used, you do not have to make allowances for any DP cycle times on PROFIBUS DP or for PROFINET IO update times.
- There is no interrupt processing.

Example II

You have configured an S7300 and equipped it with the following modules in 2 racks:

- a CPU 314C-2 PN/DP

Parameterization of the cycle load as a result of communication: 40 %

- 4 digital input modules SM 321; DI 32 x DC 24 V (each with 4 bytes in the PI)
⇒ 16 bytes in the process image
- 3 digital output modules SM 322; DO 16 x DC 24 V/0.5 A (each with 2 bytes in the PI)
⇒ 6 bytes in the process image
- 2 analog input modules SM 331; AI 8 x 12 Bit (not in the PI)
⇒ 0 bytes in the process image
- 2 analog output modules SM 332; AO 4 x 12 Bit (not in the PI)
⇒ 0 bytes in the process image

User program

- According to the instruction list, the user program runtime is 10.0 ms.

Calculating the cycle time

The cycle time for the example results from the following times:

- User program execution time:
 10 ms plus user program processing time extension of 10 % ⇒ 11.0 ms
- Process image transfer time (refer to Calculating the cycle time (Page 174)):
Process image of inputs: $150 \mu\text{s} + 16 \text{ bytes} \times 35 \mu\text{s} = \text{approx. } 0.71 \text{ ms}$
Process image of outputs: $150 \mu\text{s} + 6 \text{ bytes} \times 35 \mu\text{s} = \text{approx. } 0.36 \text{ ms}$
- Increased transfer time due to 2nd rack $40 \mu\text{s} = 0.04 \text{ ms}$
- Operating system runtime at cycle control point: 0.15 ms

The sum of the listed times is equivalent to the cycle time:

Cycle time = $11.0 \text{ ms} + 0.71 \text{ ms} + 0.36 \text{ ms} + 0.04 \text{ ms} + 0.15 \text{ ms} = 12.26 \text{ ms}$

Calculation of the actual cycle time

Taking into account the communication load of 40%:

$$12.26 \text{ ms} \times 100 / (100 - 40) = 20.43 \text{ ms}$$

Thus, considering the time slices, the **actual cycle time** is **20.43 ms**.

Calculating the longest response time

- Actual cycle time x 2 = 20.43 ms x 2 = 40.86 ms.
- Delay times of the inputs and outputs
 - The digital input module SM 321; DI 32 x DC 24 V has an input delay of not more than **4.8 ms** per channel.
 - The digital output module SM 322; DO 16 x DC 24 V/0.5 A has a **negligible** output delay.
 - The analog input module SM 331; AI 8 x 12 Bit was parameterized for an interference frequency suppression of 50 Hz. The result is a conversion time of 22 ms per channel. Since 8 channels are active, the result is a cycle time of **176 ms** for the analog input module.
 - The analog output module SM 332; AO 4 x 12 Bit was parameterized for the measuring range of 0 to 10 V. This results in a conversion time of 0.8 ms per channel. Since 4 channels are active, the result is a cycle time of 3.2 ms. A settling time of 0.1 ms for a resistive load must be added to this value. The result is a response time of **3.3 ms** for an analog output.
- Since neither PROFIBUS DP nor PROFINET IO are being used, you do not have to make allowances for any DP cycle times on PROFIBUS DP or for PROFINET IO update times.
- Response times plus delay times of the inputs and outputs:
 - **Scenario 1:** An output channel of the digital output module is set when a digital input signal is read in. The result is as follows:
Response time = 40.86 ms + 4.8 ms = 45.66 ms.
 - **Scenario 2:** An analog value is read in, and an analog value is output. The result is as follows:
Longest response time = 40.86 ms + 176 ms + 3.3 ms = 220.16 ms.

6.6 Interrupt response time

6.6.1 Overview: Interrupt response time

Definition of interrupt response time

The interrupt response time is the time from the first occurrence of an alarm signal to executing the first operation in the interrupt OB. General rule: Higher priority interrupts are handled first. This means that the interrupt response time is extended by the program execution time of the higher priority interrupt OBs and interrupt OBs with the same priority that occurred earlier and have not been processed yet (queue).

Calculation

The formulas below show how you can calculate the minimum and maximum interrupt response times.

Table 6- 13 Process and diagnostic interrupt response times

Calculation of the minimum interrupt response time	Calculation of the maximum interrupt response time
Minimum interrupt response time of the CPU + Minimum interrupt response time of the signal modules + PROFINET IO update time (only if PROFINET IO is used) + DP cycle time on PROFIBUS DP (only if PROFIBUS DP is used)	Maximum interrupt response time of the CPU + Maximum interrupt response time of the signal modules + 2 x PROFINET IO update time (only if PROFINET IO is used) + 2 x DP cycle time on PROFIBUS DP (only if PROFIBUS DP is used)
= Shortest interrupt response time	= Longest interrupt response time

Increasing the maximum interrupt response time with communication

The maximum interrupt response time is extended when the communication functions are active. The additional time is calculated using the following formula:

$$t_v: 200 \mu s + 1000 \mu s \times n\%$$

n = Setting of the cycle load as a result of communication

The result is added to the maximum interrupt response time.

Process/diagnostic interrupt response times of the CPUs

Table 6- 14 Process and diagnostic interrupt response times

CPU	Hardware interrupt response times			Diagnostic interrupt response times	
	external min.	external max.	Integrated I/O max.	min.	max.
CPU 312	0.3 ms	0.5 ms	-	0.4 ms	0.6 ms
CPU 312C	0.3 ms	0.5 ms	0.5 ms	0.4 ms	0.6 ms
CPU 313C	0.3 ms	0.5 ms	0.5 ms	0.4 ms	0.6 ms
CPU 313C-2	0.3 ms	0.5 ms	0.5 ms	0.4 ms	0.6 ms
CPU 314	0.3 ms	0.5 ms	-	0.4 ms	0.6 ms
CPU 314C-2	0.3 ms	0.5 ms	0.5 ms	0.4 ms	0.6 ms
CPU 314C-2 PN/DP	0.3 ms	0.5 ms	0.5 ms	0.4 ms	0.6 ms
CPU 315-2 DP CPU 315-2 PN/DP	0.3 ms	0.5 ms	-	0.4 ms	0.6 ms
CPU 317-2 DP CPU 317-2 PN/DP	0.2 ms	0.4 ms	-	0.2 ms	0.4 ms
CPU 319-3 PN/DP	0.2 ms	0.4 ms	-	0.2 ms	0.4 ms

Signal modules

The **hardware interrupt response time** of signal modules is determined by the following factors:

- Digital input modules

Hardware interrupt response time = internal interrupt processing time + input delay

You will find these times in the data sheet for the respective digital input module.

- Analog input modules

Hardware interrupt response time = internal interrupt processing time + conversion time

The internal interrupt processing time for analog input modules can be neglected. The conversion times can be found in the data sheet for the individual analog input modules.

The **diagnostic interrupt response time** of signal modules is equivalent to the period that expires between the time a signal module detects a diagnostic event and the time this signal module triggers the diagnostic interrupt. This short time can be neglected.

Hardware interrupt processing

Hardware interrupt processing begins when the hardware interrupt OB 40 is called. Higher-priority interrupts stop hardware interrupt processing. Direct access to I/O modules is executed during the execution time of the operation. After hardware interrupt processing has terminated, cyclic program execution continues or further interrupt OBs of equal or lower priority are called and processed.

6.6.2 Reproducibility of time-delay and watchdog interrupts

Definition of "reproducibility"

Time-delay interrupt:

The time between the call of the first instruction of the interrupt OBs up to the programmed time of interrupt.

Cyclic interrupt:

The fluctuation range of the interval between two successive calls, measured between the respective initial operations of the interrupt OB.

Reproducibility

The following times apply for the CPUs described in this manual, with the exception of CPU 319:

- Time-delay interrupt: $\pm 100 \mu\text{s}$
- Cyclic interrupt: $\pm 100 \mu\text{s}$

The following times apply in the case of CPU 319:

- Time-delay interrupt: $\pm 60 \mu\text{s}$
- Cyclic interrupt: $\pm 60 \mu\text{s}$

These times only apply if the interrupt can actually be executed at this time and if it is not delayed, for example, by higher-priority interrupts or queued interrupts of equal priority.

ماكان كنترول

6.7 Example of interrupt response time calculation

Design

You have set up an S7-300, consisting of a CPU 314C-2 PN/DP and 4 digital modules, in the central rack. One digital input module is the SM 321; DI 16 x DC 24 V, with hardware and diagnostic interrupts.

You have enabled only the hardware interrupt in your CPU and SM parameterization. You decided not to use time-driven processing, diagnostics or error handling. You have set a cycle load of 20% due to communication.

You have parameterized an input delay of 0.5 ms for the digital input modules.

No activities are required at the cycle control point.

Calculation

In this example, the hardware interrupt response time is based on following time factors:

- Hardware interrupt response time of CPU 314C-2 PN/DP: 0.5 ms
- Extension due to communication according to the formula (refer to Overview: Interrupt response time (Page 196)):
 $200 \mu\text{s} + 1000 \mu\text{s} \times 20\% = 400 \mu\text{s} = 0.4 \text{ ms}$
- The hardware interrupt response time of the SM 321; DI 16 x DC 24 V:
 - Internal interrupt processing time: 0.25 ms
 - Input delay: 0.5 ms
- Since neither PROFIBUS DP nor PROFINET IO are being used, you do not have to make allowances for any DP cycle times on PROFIBUS DP or for PROFINET IO update times.

The hardware interrupt response time is equivalent to the sum of the listed time factors:

Process interrupt response time = 0.5 ms + 0.4 ms + 0.25 ms + 0.5 ms = **1.65 ms**.

This calculated hardware interrupt response time expires between the time a signal is received at the digital input and the first operation in OB 40.



ماکان کنترول

General technical specifications

7.1 Standards and certifications

Introduction

Contents of general technical specifications:

- standards and test values satisfied by modules of the S7-300 automation system
- test criteria of S7-300 modules.

Note

Information about the nameplate

You will find the current identifiers and approvals on the rating plate of the respective product.

Safety information

WARNING

Personal injury and damage to property may occur.

In potentially explosive environments, there is a risk of personal injury and damage to property if you remove S7-300 connectors in runtime.

In potentially explosive environments, always isolate the S7-300 before you remove any connectors.

WARNING

Explosion hazard

If you replace components, compliance with Class I, DIV. 2 could be compromised.

WARNING

This device is only appropriate for use in Class I, Div. 2, Group A, B, C, D, or in non-hazardous areas.

Test logos and their meaning

The section below describes the test logos attached to the module and explains their meaning.

CE Label



The S7-300 automation system satisfies requirements and safety-related objectives according to EC Directives listed below, and conforms with the harmonized European standards (EN) for programmable controllers announced in the Official Journals of the European Community:

- 2006/95/EC "Electrical Equipment Designed for Use within Certain Voltage Limits" (Low-Voltage Directive)
- 2004/108/EC "Electromagnetic Compatibility" (EMC Directive)
- 94/9/EC "Equipment and protective systems intended for use in potentially explosive atmospheres" (Explosion Protection Directive)

The EC declaration of conformity is held on file available to competent authorities at:

Siemens AG
Industry Sector
I IA AS R&D DH A
P.O. Box 1963
D-92209 Amberg

These files are also available for download on the Customer Support Internet pages, keyword "Declaration of Conformity".

UL approval



Underwriters Laboratories Inc., complying with

- UL 508 (Industrial Control Equipment)

CSA approval



Canadian Standards Association to

- C22.2 No. 142 (Process Control Equipment)

or

cULus approval



Underwriters Laboratories Inc., complying with

- UL 508 (Industrial Control Equipment)
- CSA C22.2 No. 142 (Process Control Equipment)

or

cULus HAZ. LOC approval



Underwriters Laboratories Inc., complying with

- UL 508 (Industrial Control Equipment)
- CSA C22.2 No. 142 (Process Control Equipment)
- UL 1604 (Hazardous Location)
- CSA C22.2 No. 213 (Hazardous Location)

APPROVED for use in
Class I, Division 2, Group A, B, C, D Tx;
Class I, Zone 2, Group IIC Tx

FM approval



Factory Mutual Research (FM) to
Approval Standard Class Number 3611, 3600, 3810
APPROVED for use in Class I, Division 2, Group A, B, C, D Tx;
Class I, Zone 2, Group IIC Tx

ATEX approval



In accordance with EN 60079-15 (Electrical Apparatus for Potentially Explosive Atmospheres; Type of Protection "n") and EN 60079-0 (Electrical apparatus for potentially explosive gas atmospheres - Part 0: General Requirements)



II 3 G Ex nA II T4..T6

WARNING

Personal injury and damage to property may occur.

In potentially explosive environments, there is a risk of personal injury and damage to property if you remove S7-300 connectors in runtime.

In potentially explosive environments, always isolate the S7-300 before you remove any connectors.

Tick mark for Australia and New Zealand



The S7-300 automation system meets requirements of standards to AS/NZS CISPR 16.

Note

The UL/CSA or cULus approvals for your product are specified by the identifiers on the rating plate.

IEC 61131

The S7-300 automation system satisfies requirements and criteria to IEC 61131-2 (Programmable Controllers, Part 2: Equipment requirements and tests).

Marine approval

Classification societies:

- ABS (American Bureau of Shipping)
- BV (Bureau Veritas)
- DNV (Det Norske Veritas)
- GL (Germanischer Lloyd)
- LRS (Lloyds Register of Shipping)
- Class NK (Nippon Kaiji Kyokai)

Use in industrial environments

SIMATIC products are designed for industrial applications.

Table 7- 1 Use in industrial environments

Field of application	Noise emission requirements	Noise immunity requirements
Industry	EN 61000-6-4: 2007	EN 61000-6-2: 2005

Use in residential areas

Note

The S7-300 is intended for use in industrial environments and can cause interference on radio/television reception if operated in residential areas.

To operate an S7-300 in a residential area, its RF emission must comply with Limit Value Class B to EN 55011.

Suitable measures for achieving RF interference level Class B include, for example:

- S7-300 installation in grounded switch cabinets / cubicles
- Use of noise filters in the supply lines

ماكان كنترول

7.2 Electromagnetic compatibility

Definition

Electromagnetic compatibility (EMC) is the ability of an electrical installation to function satisfactorily in its electromagnetic environment without interfering with that environment.

The S7-300 modules also satisfy requirements of EMC legislation for the European domestic market. Compliance of the S7-300 system with specifications and directives on electric design is prerequisite.

Pulse-shaped disturbance

The table below shows the electromagnetic compatibility of S7 modules in areas subject to pulse-shaped interference.

Pulse-shaped disturbance	Test voltage	corresponds with degree of severity
Electrostatic discharge according to IEC 61000-4-2.	Air discharge: ± 8 kV	3
	Contact discharge: ± 4 kV	2
Bursts (fast transient interference in accordance with IEC 61000-4-4)	2 kV (power supply lines)	3
	2 kV (signal lines > 3 m)	3
	1 kV (signal lines < 3 m)	
High-energy single pulse (surge) to IEC 61000-4-5 External protective circuit required (see Lightning and overvoltage protection)		3
• asymmetric coupling	2 kV (power supply lines) DC with protective elements 2 kV (signal / data line only > 3 m), with protective elements as required	
• symmetric coupling	1 kV (power supply lines) DC with protective elements 1 kV (signal / data line only > 3 m), with protective elements as required	

Additional measures

When connecting an S7-300 system to the public network, always ensure compliance with Limit Value Class B to EN 55022.

Sinusoidal disturbance

The table below shows the electromagnetic compatibility of the S7-300 modules in areas subject to sinusoidal interference.

- RF radiation

RF radiation to IEC 61000-4-3 Electromagnetic RF field, amplitude-modulated		corresponds with degree of severity
80 to 1000 MHz; 1.4 to 2 GHz	2.0 GHz to 2.7 GHz	3, 2, 1
10 V/m	1 V/m	
80 % AM (1 kHz)		

- RF coupling

RF coupling to IEC 61000-4-6	corresponds with degree of severity
0.15 to 80 MHz	3
10 V _{rms} unmodulated	
80 % AM (1 kHz)	
150 Ω source impedance	

Emission of radio interference

Electromagnetic interference emission to EN 55016: Limit value class A (measured at a distance of 10 m).

Frequency	Emitted interference
30 MHz to 230 MHz	< 40 dB (μV/m)Q
230 MHz to 1000 MHz	< 47 dB (μV/m)Q

Noise emission via AC mains to EN 55016: Limit value class A, Group 1.

Frequency	Emitted interference
0.15 to 0.5 MHz	< 79 dB (μV/m)Q
	< 66 dB (μV/m)M
0.5 MHz to 5 MHz	< 73 dB (μV/m)Q
	< 60 dB (μV/m)M
5 MHz to 30 MHz	< 73 dB (μV/m)Q
	< 60 dB (μV/m)M

7.3 Transportation and storage conditions for modules

Introduction

The shipping and storage conditions of S7-300 modules surpass requirements to IEC 61131-2. The data below apply to modules shipped or put on shelf in their original packing.

The modules are compliant with climatic conditions to IEC 60721-3-3, Class 3K7 (storage), and with IEC 60721-3-2, Class 2K4 (shipping.)

Mechanical conditions are compliant with IEC 60721-3-2, Class 2M2.

Shipping and storage conditions for modules

Type of condition	Permissible range
Free fall (in shipping package)	≤ 1 m
Temperature	From -40 °C to $+70$ °C
Barometric pressure	1080 hPa to 660 hPa (corresponds with an altitude of -1000 m to 3500 m)
Relative humidity	10% to 95%, no condensation
Sinusoidal oscillation to IEC 60068-2-6	5 - 9 Hz: 3.5 mm 9 - 150 Hz: 9.8 m/s ²
Shock to IEC 60068-2-29	250 m/s ² , 6 ms, 1000 shocks

ماکان کنترول

7.4 Mechanical and climatic environmental conditions for S7-300 operation

Operating conditions

S7-300 systems are designed for stationary use in weather-proof locations. The operating conditions surpass requirements to DIN IEC 60721-3-3.

- Class 3M3 (mechanical requirements)
- Class 3K3 (climatic requirements)

Use with additional measures

The S7-300 may not be used under the conditions outlined below without taking additional measures:

- At locations with a high degree of ionizing radiation
- In aggressive environments caused, for example, by
 - The development of dust
 - Corrosive vapors or gases
 - Strong electric or magnetic fields
- In installations requiring special monitoring, for example
 - Elevators
 - Electrical plants in potentially hazardous areas

An additional measure could be an installation of the S7-300 in a cabinet or housing.

Mechanical environmental conditions

The table below shows the mechanical environmental conditions in the form of sinusoidal oscillations.

Frequency band	Continuous	Infrequently
$10 \leq f \leq 58$ Hz	0,0375 mm amplitude	0.75 mm amplitude
$58 \leq f \leq 150$ Hz	0,5 g constant acceleration	1 g constant acceleration

Reducing vibrations

If your S7-300 modules are exposed to severe shock or vibration, take appropriate measures to reduce acceleration or the amplitude.

We recommend the installation of the S7-300 on damping materials (for example, rubber-bonded-to-metal mounting.)

Test of mechanical environmental conditions

The table below provides important information with respect to the type and scope of the test of ambient mechanical conditions.

Condition tested	Test Standard	Comment
Vibration	Vibration test to IEC 60068-2-6 (sinusoidal)	Type of oscillation: Frequency sweeps with a rate of change of 1 octave/minute. 5 Hz ≤ f ≤ 9 Hz, 3.5 mm constant amplitude 9 Hz ≤ f ≤ 150 Hz, 1 g constant acceleration Duration of oscillation: 10 frequency sweeps per axis at each of three vertically aligned axes
Shock	Shock, tested to IEC 60068-2-27	Type of shock: Half-sine Shock intensity: 15 g peak value, 11 ms duration Direction of shock: 3 shocks in each direction (+/-) at each of three vertically aligned axes

Climatic environmental conditions

The S7-300 may be operated on following environmental conditions:

Environmental conditions	Permissible range	Comments
Temperature: horizontal mounting position: vertical mounting position:	0°C to 60 °C 0°C to 40 °C	-
Relative humidity	from 10 to 95%	No condensation, corresponds to relative humidity (RH) Class 2 to IEC 61131, Part 2
Barometric pressure	1080 hPa to 795 hPa	Corresponds with an altitude of -1000 m to 2000 m
Concentration of pollutants	SO ₂ : < 0.5 ppm; RH < 60 %, no condensation H ₂ s: < 0.1 ppm; RH < 60 %, no condensation	Test: 10 ppm; 4 days Test: 1 ppm; 4 days
	ISA-S71.04 severity level G1; G2; G3	-

7.5 Specification of dielectric tests, protection class, degree of protection, and rated voltage of S7-300

Test voltage

Proof of dielectric strength must be provided in the type test at a test voltage to IEC 61131-2:

Circuits with rated voltage V_e to other circuits or ground.	Test voltage
< 50 V	500 VDC
< 150 V	2500 V DC
< 250 V	4000 V DC

Protection class

Protection class I to IEC 60536, i.e., a protective conductor must be connected to the mounting rail!

Protection against the ingress of foreign matter and water

- Degree of protection IP 20 to IEC 60529, i.e., protection against contact with standard probes.

No protection against the ingress of water.

7.6 Rated voltages of S7-300

Rated operating voltages

The S7-300 modules operate at different rated voltages. The table shows the rated voltages and corresponding tolerances.

Rated voltages	Tolerance
24 V DC	19.2 V DC to 28.8 V DC
120 VAC	93 VAC to 132 VAC
230 VAC	187 VAC to 264 VAC

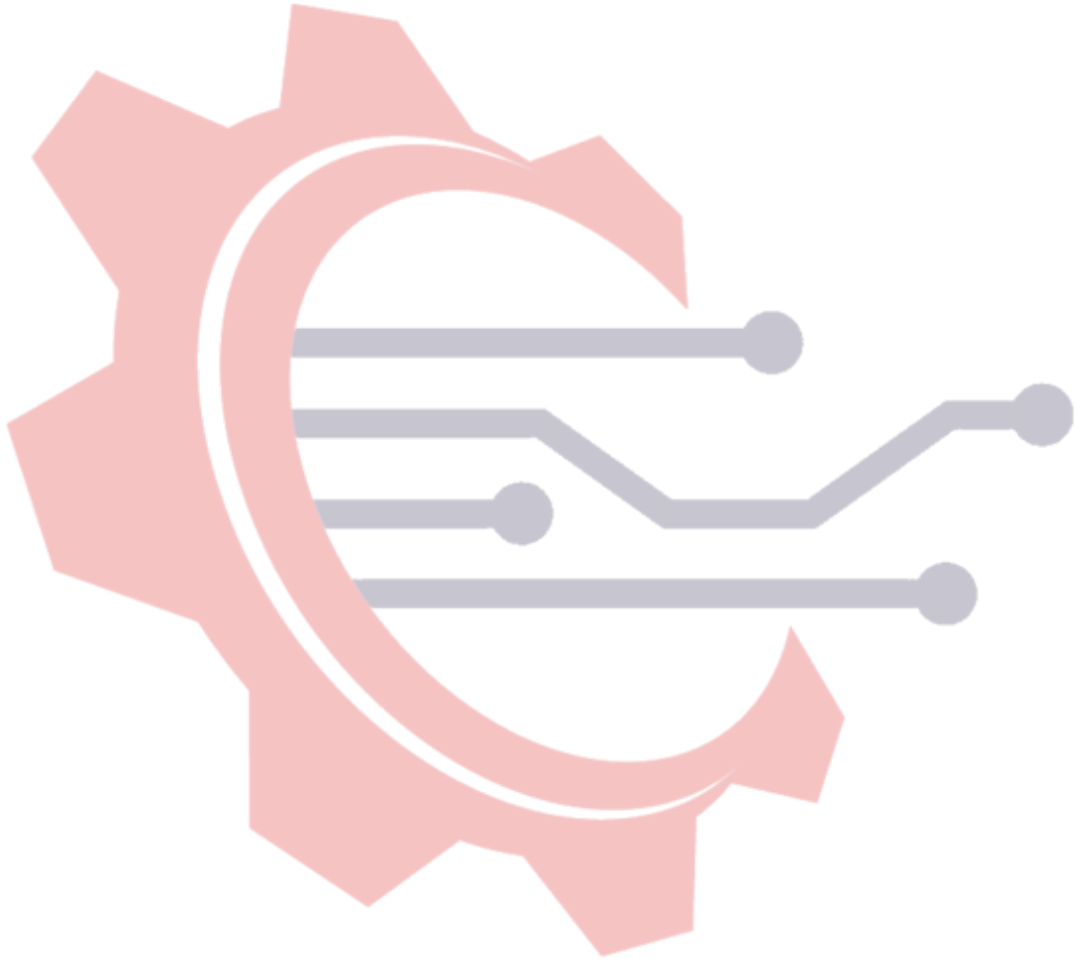

ماکان کنترول

Technical specifications of CPU 31xC

8.1 General technical specifications

8.1.1 Dimensions of CPU 31xC

Each CPU features the same height and depth, only the width differs.

- Height: 125 mm
- Depth: 115 mm, or 180 mm with opened front cover

Width of CPU

CPU	Width
CPU 312C	80 mm
CPU 313C	120 mm
CPU 313C-2 PtP	80 mm
CPU 313C-2 DP	80 mm
CPU 314C-2 PtP	120 mm
CPU 314C-2 DP	120 mm
CPU 314C2 PN/DP	120 mm

ماکان کنترول

8.1.2 Technical specifications of the Micro Memory Card

Compatible SIMATIC Micro Memory Cards

The following memory modules are available:

Table 8- 1 Available SIMATIC Micro Memory Cards

Type of Micro Memory Card	Order number	Required for a firmware update via SIMATIC Micro Memory Card
64 KB	6ES7953-8LFxx-0AA0	-
128 KB	6ES7953-8LGxx-0AA0	-
512 KB	6ES7953-8LJxx-0AA0	-
2 MB	6ES7953-8LLxx-0AA0	Minimum requirement for CPUs without DP interface
4 MB	6ES7953-8LMxx-0AA0	Minimum requirements for CPUs with DP interface, but without PN interface
8 MB	6ES7953-8LPxx-0AA0	Minimum requirements for CPUs with DP and PN interface

Maximum number of loadable blocks on the SIMATIC Micro Memory Card

The number of blocks that can be stored on the SIMATIC Micro Memory Card depends on the capacity of the SIMATIC Micro Memory Card being used. The maximum number of blocks that can be loaded is therefore limited by the capacity of your SIMATIC Micro Memory Card (including blocks generated with the "CREATE DB" SFC)

Table 8- 2 Maximum number of loadable blocks on the SIMATIC Micro Memory Card

Size of SIMATIC Micro Memory Card	... Maximum number of blocks that can be loaded
64 KB	768
128 KB	1024
512 KB	2560
2 MB	The maximum number of blocks that can be loaded on a specific CPU is less than the number of blocks that can be stored on the SIMATIC Micro Memory Card. For information about the maximum number of blocks that can be loaded on a specific CPU, refer to the corresponding technical specification.
4 MB	
8 MB	

8.2 CPU 312C

Technical specifications

Table 8- 3 Technical specifications of CPU 312C

Technical specifications	
CPU and version	
• MLFB	6ES7312-5BF04-0AB0
• Hardware version	01
• Firmware version	V3.3
• Associated programming package	STEP 7 as of V5.5 + SP1 or STEP 7 as of V5.3 + SP2 with HSP 203
Memory	
Main memory	
• Integrated	64 KB
• Expandable	No
• Maximum size of non-volatile memory for retentive data blocks	64 KB
Load memory	
• Pluggable (MMC)	Yes
• Pluggable (MMC), max.	8 MB
• Minimum data retention on the Micro Memory Card (after the last programming action)	10 years
Backup	
• Available	Yes (ensured with Micro Memory Card - maintenance-free)
• Without battery	Yes (program and data)
Execution times	
• For bit operation, min.	0.1 μ s
• For word operations, min.	0.24 μ s
• For fixed-point arithmetic, min.	0.32 μ s
• Minimum for floating-point arithmetic	1.1 μ s
Timers/counters and their retentivity	
S7 counters	
• Number	256

Technical specifications	
Retentivity	
• Configurable	Yes
• Default	Z 0 to Z 7
Counting range	
• Low limit	0
• High limit	999
IEC counter	
• Available	Yes
• Type	SFB
• Number	Unlimited (limited only by main memory size)
S7 timers	
• Number	256
Retentivity	
• Configurable	Yes
• Default	No retentivity
Time setting range	
• Low limit	10 ms
• High limit	9990 s
IEC timer	
• Available	Yes
• Type	SFB
• Number	Unlimited (limited only by main memory size)
Data areas and their retentivity	
Bit memory	
• Number, max.	256 bytes
• Retentivity, available	Yes (from MB 0 to MB 255)
• Retentivity, default	From MB 0 to MB 15
• Number of clock memories	8 (1 memory byte)
Data blocks	
• Number, max.	1024 (in the number range 1 to 16000)
• Size, max.	64 kB
• Retentivity, configurable	Yes, via non-retain feature on the DB
• Retentivity, default	Yes
Local data	
• Per priority class, max.	32 KB (max. 2048 bytes per block)

Technical specifications	
Blocks	
• Number of blocks (total)	1024 (DBs, FCs, FBs) The maximum number of blocks that can be loaded may be reduced due to the Micro Memory Card you are using.
OB	See instruction list
• Size, max.	64 KB
• Number of free cycle OBs	1 (OB 1)
• Number of time-of-day interrupt OBs	1 (OB 10)
• Number of time-delay interrupt OBs	2 (OB 20, 21)
• Number of cyclic interrupt OBs	4 (OB 32, 33, 34, 35)
• Number of hardware interrupt OBs	1 (OB 40)
• Number of restart OBs	1 (OB 100)
• Number of asynchronous error OBs	4 (OB 80, 82, 85, 87)
• Number of synchronous error OBs	2 (OB 121, 122)
Nesting depth	
• Per priority class	16
• Additionally within an error OB	4
FB	See instruction list
• Number, max.	1024 (in the number range 0 to 7999)
• Size	64 KB
FC	See instruction list
• Number, max.	1024 (in the number range 0 to 7999)
• Size	64 KB
Address ranges (inputs/outputs)	
I/O address area	
• Inputs	1024 bytes (freely addressable)
• Outputs	1024 bytes (freely addressable)
Distributed	
• Inputs	-
• Outputs	-
I/O process image	
• Inputs	1024 bytes
• Outputs	1024 bytes
• Inputs, adjustable	1024 bytes

Technical specifications	
• Outputs, adjustable	1024 bytes
• Inputs, preset	128 bytes
• Outputs, preset	128 bytes
Digital channels	
• Integrated channels (DI)	10
• Integrated channels (DO)	6
• Inputs	266
• Outputs	262
• Inputs, of those central	266
• Outputs, of those central	262
Analog channels	
• Integrated channels (AI)	-
• Integrated channels (AO)	-
• Inputs	64
• Outputs	64
• Inputs, of those central	64
• Outputs, of those central	64
Hardware configuration	
• Racks, max.	1
• Modules per rack, max.	8
Number of DP masters	
• Integrated	-
• Via CP	4
Supported number of FMs and CPs (recommended)	
• FM	8
• CP, point-to-point	8
• CP, LAN	4
Time	
Clock	
• Software clock	Yes
• Buffered	No
• Can be synchronized	Yes
• Factory setting	DT#1994-01-01-00:00:00
• Behavior of the real-time clock after POWER ON	The clock continues at the time of day it had when power was switched off.

Technical specifications	
• Deviation per day, max.	10 s, typ.: 2 s
Runtime meter	
• Number	1
• Number/number range	0
• Range of values	0 to 2 ³¹ hours (using the SFC 101)
• Granularity	1 hour
• Retentive	Yes; must be manually restarted after every restart
Clock synchronization	
• supported	Yes
• On MPI, master	Yes
• On MPI, slave	Yes
• On the AS, master	Yes
• On the AS, slave	No
S7 signaling functions	
• Number of stations that can be logged on for reporting functions, max.	6 (depends on the number of connections configured for PG/OP and S7 basic communication)
• Process error diagnostic messages	Yes
• Simultaneously enabled interrupt S blocks, max.	300
Test and startup functions	
Status/modify	
• Status/modify variable	Yes
• Variables	Inputs, outputs, bit memories, DBs, timers, counters
• Maximum number of variables	30
• Status variables, max.	30
• Modify variables, max.	14
Forcing	
• Forcing	Yes
• Variables	Inputs, outputs
• Maximum number of tags	10
Status block	Yes, up to 2 at the same time
Single step	
• Number of breakpoints	4

Technical specifications	
Diagnostic buffer	
• Available	Yes
• Maximum number of entries	500
• Configurable	No
• Of which are power-failure-proof	100, only the last 100 entries are retentive
• Maximum number of entries that can be read in RUN	499
• Number of entries that can be set in RUN	Yes, from 10 to 499
• Number of preset entries in RUN	10
Service data	
• Can be read out	Yes
Monitoring function	
• Status LEDs	Yes
Communication functions	
PG/OP communication	
	Yes
Prioritized OCM communication	
• Supported	No
Routing	
• Number of routing connections	0
• Data record routing	No
Global data communication	
• supported	Yes
• Number of GD circles, max.	8
• Number of GD packets, max.	8
• Number of GD packets, sender, max.	8
• Number of GD packets, receiver, max.	8
• Size of GD packets, max.	22 Byte
• Size of GD packets, of those consistent, max.	22 Byte
S7 basic communication	
• Supported	Yes
• User data per job, max.	76 Byte
• User data per job, consistent, max.	76 bytes (for X_SEND or X_RCV) 64 bytes (for X_PUT or X_GET as the server)
S7 communication	
• Supported	Yes
• As server	Yes

Technical specifications	
• As client	Yes, via CP and loadable FBs
• User data per job, max.	180 bytes (for PUT/GET)
• User data per job, consistent, max.	240 bytes as server
S5-compatible communication	
• Supported	Yes, via CP and loadable FCs
Number of connections	
• Total	6
Suitable for PG communication	
• PG communication, reserved	1
• PG communication, configurable, min.	1
• PG communication, configurable, max.	5
Suitable for OP communication	
• OP communication, reserved	1
• OP communication, configurable, min.	1
• OP communication, configurable, max.	5
Suitable for S7 basic communication	
• S7 basic communication, reserved	0
• S7 basic communication, configurable, min.	0
• S7 basic communication, configurable, max.	2
Connection system	
• Required front connector	1 X 40-pin
Interfaces	
1st interface	
Interface designation	X1
Type of interface	Integrated RS 485 interface
Hardware	RS 485
• electrically disconnected	No
• Interface power supply (15 V DC to 30 V DC), max.	200 mA
Functionality	
• MPI	Yes
• DP master	No
• DP slave	No
• Point-to-point connection	No
MPI	
Services	

Technical specifications	
• PG/OP communication	Yes
• Routing	No
• Global data communication	Yes
• S7 basic communication	Yes
• S7 communication	Yes (only server; connection configured at one end)
• S7 communication, as client	No, but via CP and loadable FBs
• S7 communication, as server	Yes
Transmission rate, max.	187,5 kbps
Programming	
Programming language	
• LAD	Yes
• FBD	Yes
• STL	Yes
• SCL	Yes
• GRAPH	Yes
• HiGraph®	Yes
Instruction set	See instruction list
• Nesting levels	8
Know-how protection	
• User program/password security	Yes
• Block encryption	Yes, using S7-Block Privacy
System functions (SFC)	See instruction list
System function blocks (SFB)	See instruction list
Integrated inputs/outputs	
Default addresses of the integrated	
• Digital inputs	124.0 to 125.1
• Digital outputs	124.0 to 124.5
Integrated functions	
• Number of counters	2 (see the Manual <i>Technological Functions</i>)
• Number of frequency meters	2 channels up to 10 kHz (see the Manual <i>Technological Functions</i>)
• Number of pulse outputs	2 pulse width modulations up to 2.5 kHz (see the Manual <i>Technological Functions</i>)
• Period measurement	2 channels (see the Manual <i>Technological Functions</i>)
• Open-loop positioning	No

Technical specifications	
• Integrated function blocks (rules)	No
Dimensions	
• Mounting dimensions W x H x D (mm)	80 x 125 x 130
• Weight	410 g
Voltages and currents	
• Power supply (rated value)	24 V DC
• Low limit of admissible range (DC)	19.2 V
• High limit of admissible range (DC)	28.8 V
• Current consumption (open-circuit), typically	90 mA
• Inrush current, typ.	5 A
• Current consumption (rated value)	570 mA
• I ² t	0.7 A ² s
• External protection of power supply lines (recommended)	MCB type C min. 2 A, MCB type B min. 4 A
• Power loss, typically	8 W

Reference

In the chapter *Technical specifications of the integrated I/O* you can find:

- the technical specifications of integrated I/Os under *Digital inputs of CPUs 31xC* and *Digital outputs of CPUs 31xC*.
- the block diagrams of the integrated I/Os under *Arrangement and use of integrated I/Os*.

ماكان كنترول

8.3 CPU 313C

Technical specifications

Table 8- 4 Technical specifications of CPU 313C

Technical specifications	
CPU and version	
• MLFB	6ES7313-5BG04-0AB0
• Hardware version	01
• Firmware version	V3.3
• Associated programming package	STEP 7 as of V5.5 + SP1 or STEP 7 as of V5.3 + SP2 with HSP 203
Memory	
Main memory	
• Integrated	128 KB
• Expandable	No
• Maximum size of non-volatile memory for retentive data blocks	64 KB
Load memory	
• Pluggable (MMC)	Yes
• Pluggable (MMC), max.	8 MB
• Data retention on the Micro Memory Card (after the last programming action), min.	10 years
Backup	
• Available	Yes (ensured with Micro Memory Card - maintenance-free)
• Without battery	Yes (program and data)
Execution times	
• For bit operation, min.	0.07 μ s
• For word operations, min.	0.15 μ s
• For fixed-point arithmetic, min.	0.2 μ s
• Minimum for floating-point arithmetic	0.72 μ s
Timers/counters and their retentivity	
S7 counters	
• Number	256
Retentivity	
• Configurable	Yes
• Default	Z 0 to Z 7

Technical specifications	
Counting range	
• Low limit	0
• High limit	999
IEC counter	
• Available	Yes
• Type	SFB
• Number	Unlimited (limited only by main memory size)
S7 timers	
• Number	256
Retentivity	
• Configurable	Yes
• Default	No retentivity
Time setting range	
• Low limit	10 ms
• High limit	9990 s
IEC timer	
• Available	Yes
• Type	SFB
• Number	Unlimited (limited only by main memory size)
Data areas and their retentivity	
Bit memory	
• Number, max.	256 bytes
• Retentivity, available	Yes (from MB 0 to MB 255)
• Retentivity, default	From MB 0 to MB 15
• Number of clock memories	8 (1 memory byte)
Data blocks	
• Number, max.	Max. 1024 (In the number range 1 to 16000)
• Size, max.	64 KB
• Retentivity, configurable	Yes, via non-retain feature on the DB
• Retentivity, default	Yes
Local data	
• Per priority class, max.	32 KB, max. 2048 bytes per block
Blocks	

Technical specifications	
• Number of blocks (total)	1024 (DBs, FCs, FBs) The maximum number of blocks that can be loaded may be reduced due to the Micro Memory Card you are using.
OB	See instruction list
• Size, max.	64 KB
• Number of free cycle OBs	1 (OB 1)
• Number of time-of-day interrupt OBs	1 (OB 10)
• Number of time-delay interrupt OBs	2 (OB 20, 21)
• Number of cyclic interrupt OBs	4 (OB 32, 33, 34, 35)
• Number of hardware interrupt OBs	1 (OB 40)
• Number of restart OBs	1 (OB 100)
• Number of asynchronous error OBs	4 (OB 80, 82, 85, 87)
• Number of synchronous error OBs	2 (OB 121, 122)
Nesting depth	
• Per priority class	16
• Additionally within an error OB	4
FB	See instruction list
• Number, max.	1024 (in the number range 0 to 7999)
• Size	64 KB
FC	See instruction list
• Number, max.	1024 (in the number range 0 to 7999)
• Size	64 KB
Address ranges (inputs/outputs)	
I/O address area	
• Inputs	1024 bytes (freely addressable)
• Outputs	1024 bytes (freely addressable)
I/O process image	
• Inputs	1024 bytes
• Outputs	1024 bytes
• Inputs, adjustable	1024 bytes
• Outputs, adjustable	1024 bytes
• Inputs, preset	128 bytes
• Outputs, preset	128 bytes
Digital channels	

Technical specifications	
• Integrated channels (DI)	24
• Integrated channels (DO)	16
• Inputs	1016
• Outputs	1008
• Inputs, of those central	1016
• Outputs, of those central	1008
Analog channels	
• Integrated channels (AI)	5 (4 x current/voltage, 1 x resistance)
• Integrated channels (AO)	2
• Inputs	253
• Outputs	250
• Inputs, of those central	253
• Outputs, of those central	250
Hardware configuration	
• Racks, max.	4
• Modules per rack, max.	8; max. 7 in rack ER 3
Number of DP masters	
• Integrated	-
• Via CP	4
Number of usable FMs and CPs (recommended)	
• FM	8
• CP, point-to-point	8
• CP, LAN	6
Time	
Clock	
• Hardware clock (real-time)	Yes
• Buffered, can be synchronized	Yes
• Factory setting	DT#1994-01-01-00:00:00
• Buffered period	Typically 6 weeks (at an ambient temperature of 40 °C)
• Behavior of the real-time clock after POWER OFF ON	The clock continues running after POWER OFF
• Behavior of the clock on expiration of the buffered period	The clock continues at the time of day it had when power was switched off.
• Deviation per day, max.	10 s, typ.: 2 s

Technical specifications	
Runtime meter	
• Number	1
• Number/number range	0
• Range of values	0 to 2 ³¹ hours (if SFC 101 is used)
• Granularity	1 hour
• Retentive	Yes; must be manually restarted after every restart
Clock synchronization	
• Supported	Yes
• On MPI, master	Yes
• On MPI, slave	Yes
• On the AS, master	Yes
• On the AS, slave	No
S7 signaling functions	
• Number of stations that can be logged on for signaling functions, max.	8 (depends on the number of connections configured for PG/OP and S7 basic communication)
• Process error diagnostic messages	Yes
• Simultaneously enabled interrupt S blocks, max.	300
Test and startup functions	
Status/modify	
• Status/modify variable	Yes
• Variables	Inputs, outputs, bit memories, DBs, timers, counters
• Maximum number of variables	30
• Status variables, max.	30
• Modify variables, max.	14
Forcing	
• Forcing	Yes
• Variables	Inputs, outputs
• Maximum number of tags	10
• Status block	Yes, up to 2 at the same time
Single step	
• Number of breakpoints	4

Technical specifications	
Diagnostic buffer	
• Available	Yes
• Maximum number of entries	500
• Configurable	No
• of which are power-failure-proof	100; only the last 100 entries are retentive
• Maximum number of entries that can be read in RUN	499
• Number of entries that can be set in RUN	Yes, from 10 to 499
• Number of preset entries in RUN	10
Service data	
• Can be read out	Yes
Monitoring function	
• Status LEDs	Yes
Communication functions	
PG/OP communication	Yes
Prioritized OCM communication	
• Supported	No
Routing	
• Number of routing connections	0
• Data record routing	No
Global data communication	
• Supported	Yes
• Number of GD circles, max.	8
• Number of GD packets, max.	8
• Number of GD packets, sender, max.	8
• Number of GD packets, receiver, max.	8
• Size of GD packets, max.	22 bytes
• Size of GD packets, of those consistent, max.	22 bytes
S7 basic communication	
• Supported	Yes
• User data per job, max.	76 bytes
• User data per job, consistent, max.	76 bytes (for X_SEND or X_RCV) 64 bytes (for X_PUT or X_GET as the server)
S7 communication	
• Supported	Yes
• As server	Yes

Technical specifications	
• As client	Yes (via CP and loadable FBs)
• User data per job, max.	180 bytes (with PUT/GET)
• User data per job, consistent	240 bytes (as server)
S5-compatible communication	
• Supported	Yes (via CP and loadable FCs)
Number of connections	
• Total	8
Suitable for PG communication	
• PG communication, reserved	1
• PG communication, configurable, min.	1
• PG communication, configurable, max.	7
Suitable for OP communication	
• OP communication, reserved	1
• OP communication, configurable, min.	1
• OP communication, configurable, max.	7
Suitable for S7 basic communication	
• S7 basic communication, reserved	0
• S7 basic communication, configurable, min.	0
• S7 basic communication, configurable, max.	4
Connection system	
• Required front connector	2 X 40-pin
Interfaces	
1st interface	
Interface designation	X1
Type of interface	Integrated RS 485 interface
Hardware	RS 485
• electrically disconnected	No
• Interface power supply (15 V DC to 30 V DC), max.	200 mA
Functionality	
• MPI	Yes
• DP master	No
• DP slave	No
• Point-to-point connection	No

Technical specifications	
MPI	
Services	
• PG/OP communication	Yes
• Routing	No
• Global data communication	Yes
• S7 basic communication	Yes
• S7 communication	Yes (only server; connection configured at one end)
• S7 communication, as client	No (but via CP and loadable FBs)
• S7 communication, as server	Yes
Transmission rate, max.	187.5 kbps
Programming	
Programming language	
• LAD	Yes
• FBD	Yes
• STL	Yes
• SCL	Yes
• CFC	Yes
• GRAPH	Yes
• HiGraph®	Yes
Instruction set	See instruction list
• Nesting levels	8
Know-how protection	
• User program/password security	Yes
• Block encryption	Yes, using S7-Block Privacy
System functions (SFC)	See instruction list
System function blocks (SFB)	See instruction list
Integrated inputs/outputs	
Default addresses of the integrated	
Digital inputs	124.0 to 126.7
Digital outputs	124.0 to 125.7
Analog inputs	752 to 761
Analog outputs	752 to 755

Technical specifications	
Integrated functions	
• Number of counters	3 (see the manual <i>Technological Functions</i>)
• Number of frequency meters	3 up to 30 kHz (see the manual <i>Technological Functions</i>)
• Number of pulse outputs	3 channels for pulse width modulation up to 2.5 kHz (see the manual <i>Technological Functions</i>)
• Period measurement	3 channels (see the manual <i>Technological Functions</i>)
• Open-loop positioning	No
• Integrated function blocks (rules)	Yes, PID controller (see Manual <i>Technological Functions</i>)
Dimensions	
• Mounting dimensions W x H x D (mm)	120 x 125 x 130
• Weight	660 g
Voltages and currents	
• Power supply (rated value)	24 V DC
• Low limit of admissible range (DC)	19.2 V
• High limit of admissible range (DC)	28.8 V
• Current consumption (open-circuit), typically	150 mA
• Inrush current, typ.	5 A
• Current consumption (rated value)	650 mA
• I ² t	0.7 A ² s
• External protection of power supply lines (recommended)	MCB type C min. 2 A, MCB type B min. 4 A
• Power loss, typically	12 W

Reference

In the chapter *Technical specifications of the integrated I/O* you can find:

- the technical specifications of the integrated I/Os under *Digital inputs of CPUs 31xC*, *Digital outputs of CPUs 31xC*, *Analog inputs of CPUs 31xC* and *Analog outputs of CPUs 31xC*.
- the block diagrams of the integrated I/Os under *Arrangement and use of integrated I/Os*.

8.4 CPU 313C-2 PtP and CPU 313C-2 DP

Technical specifications

Table 8- 5 Technical specifications of the CPU 313C-2 PtP/ CPU 313C-2 DP

Technical specifications		
	CPU 313C-2 PtP	CPU 313C-2 DP
CPU and version	CPU 313C-2 PtP	CPU 313C-2 DP
• MLFB	6ES7313-6BG04-0AB0	6ES7313-6CG04-0AB0
• Hardware version	01	01
• Firmware version	V3.3	V3.3
• Associated programming package	STEP 7 as of V5.5 + SP1 or STEP 7 as of V5.3 + SP2 with HSP 204	STEP 7 as of V5.5 + SP1 or STEP 7 as of V5.3 + SP2 with HSP 203
Memory	CPU 313C-2 PtP	CPU 313C-2 DP
Main memory		
• Integrated	128 KB	
• Expandable	No	
• Maximum size of non-volatile memory for retentive data blocks	64 KB	
Load memory		
• Pluggable (MMC)	Yes	
• Pluggable (MMC), max.	8 MB	
• Data retention on the Micro Memory Card (after the last programming action), min.	10 years	
Backup		
• Available	Yes (ensured with Micro Memory Card - maintenance-free)	
• Without battery	Yes (program and data)	
Execution times	CPU 313C-2 PtP	CPU 313C-2 DP
• For bit operation, min.	0.07 µs	
• For word operations, min.	0.15 µs	
• For fixed-point arithmetic, min.	0.2 µs	
• Minimum for floating-point arithmetic	0.72 µs	
Timers/counters and their retentivity	CPU 313C-2 PtP	CPU 313C-2 DP
S7 counters		
• Number	256	

Technical specifications		
	CPU 313C-2 PtP	CPU 313C-2 DP
Retentivity		
• Configurable	Yes	
• Default	From C 0 to C 7	
Counting range		
• Low limit	0	
• High limit	999	
IEC counter		
• Available	Yes	
• Type	SFB	
• Number	Unlimited (limited only by main memory size)	
S7 timers		
• Number	256	
Retentivity		
• Configurable	Yes	
• Default	No retentivity	
Time setting range		
• Low limit	10 ms	
• High limit	9990 s	
IEC timer		
• Available	Yes	
• Type	SFB	
• Number	Unlimited (limited only by main memory size)	
Data areas and their retentivity		
	CPU 313C-2 PtP	CPU 313C-2 DP
Bit memory		
• Number, max.	256 bytes	
• Retentivity, available	Yes (MB 0 to MB 255)	
• Retentivity, default	MB 0 to MB15	
• Number of clock memories	8 (1 memory byte)	
Data blocks		
• Number, max.	1024 (in the number range 1 to 16000)	
• Size, max.	64 KB	
• Retentivity, configurable	Yes, via non-retain feature on the DB	
• Retentivity, default	Yes	

Technical specifications		
	CPU 313C-2 PtP	CPU 313C-2 DP
Local data		
• Per priority class, max.	32 kByte, Max. 2048 bytes per block	
Blocks		
• Number of blocks (total)	1024 (DBs, FCs, FBs) The maximum number of blocks that can be loaded may be reduced due to the Micro Memory Card you are using.	
OB		
• Size, max.	64 KB	
• Number of free cycle OBs	1 (OB 1)	
• Number of time-of-day interrupt OBs	1 (OB 10)	
• Number of time-delay interrupt OBs	2 (OB 20, 21)	
• Number of cyclic interrupt OBs	4 (OB 32, 33, 34, 35)	
• Number of hardware interrupt OBs	1 (OB 40)	
• Number of DPV1 interrupt OBs	-	3 (OB 55, 56, 57)
• Number of restart OBs	1 (OB 100)	
• Number of asynchronous error OBs	4 (OB 80, 82, 85, 87)	5 (OB 80, 82, 85, 86, 87)
• Number of synchronous error OBs	2 (OB 121, 122)	
Nesting depth		
• Per priority class	16	
• Additionally within an error OB	4	
FB		
• Number, max.	1024 (in the number range 0 to 7999)	
• Size	64 KB	
FC		
• Number, max.	1024 (in the number range 0 to 7999)	
• Size	64 KB	
Address ranges (inputs/outputs)		
I/O address area		
• Inputs	1024 bytes	2048 bytes
• Outputs	1024 bytes	2048 bytes
Distributed		
• Inputs	-	2030 bytes
• Outputs	-	2030 bytes

Technical specifications		
	CPU 313C-2 PtP	CPU 313C-2 DP
I/O process image		
• Inputs	1024 bytes	2048 bytes
• Outputs	1024 bytes	2048 bytes
• Inputs, adjustable	1024 bytes	2048 bytes
• Outputs, adjustable	1024 bytes	2048 bytes
• Inputs, preset	128 bytes	128 bytes
• Outputs, preset	128 bytes	128 bytes
Digital channels		
• Integrated channels (DI)	16	
• Integrated channels (DO)	16	
• Inputs	1008	16256
• Outputs	1008	16256
• Inputs, of those central	1008	1008
• Outputs, of those central	1008	1008
Analog channels		
• Integrated channels	-	-
• Integrated channels	-	-
• Inputs	248	1015
• Outputs	248	1015
• Inputs, of those central	248	248
• Outputs, of those central	248	248
Hardware configuration		
• Racks, max.	4	
• Modules per rack, max.	8; max. 7 in rack ER 3	
Number of DP masters		
• Integrated	No	1
• Via CP	4	4
Number of usable FMs and CPs (recommended)		
• FM	8	
• CP, point-to-point	8	
• CP, LAN	6	

Technical specifications		
	CPU 313C-2 PtP	CPU 313C-2 DP
Time	CPU 313C-2 PtP	CPU 313C-2 DP
Clock		
• Hardware clock (real-time)	Yes	
• Buffered, can be synchronized	Yes	
• Factory setting	DT#1994-01-01-00:00:00	
• Buffered period	Typically 6 weeks (at an ambient temperature of 40 °C)	
• Behavior of the real-time clock after POWER OFF POWER ON	The clock continues running after POWER OFF	
• Behavior after expiration of the buffered period	The clock continues at the time of day it had when power was switched off.	
• Deviation per day, max.	10 s, typ.: 2 s	
Runtime meter		
• Number	1	
• Number/number range	0	
• Range of values	0 to 2 ³¹ hours (using the SFC 101)	
• Granularity	1 hour	
• Retentive	Yes; must be manually restarted after every restart	
Clock synchronization		
• Supported	Yes	
• On MPI, master	Yes	Yes
• On MPI, slave	Yes	Yes
• On DP, master	-	Yes, DP slave must be time slave
• On DP, slave	-	Yes
• On the AS, master	Yes	Yes
• On the AS, slave	No	No
S7 signaling functions		
CPU 313C-2 PtP		
CPU 313C-2 DP		
• Number of stations that can be logged on for signaling functions (e.g. OS)	8	
• Process error diagnostic messages	Yes	
• Simultaneously enabled interrupt S blocks, max.	300	

Technical specifications		
	CPU 313C-2 PtP	CPU 313C-2 DP
Test and startup functions	CPU 313C-2 PtP	CPU 313C-2 DP
Status/modify		
• Status/modify variable	Yes	
• Variable	Inputs, outputs, bit memories, DBs, timers, counters	
• Maximum number of variables	30	
• Status variables, max.	30	
• Modify variables, max.	14	
Forcing		
• Forcing	Yes	
• Variables	Inputs, outputs	
• Maximum number of tags	10	
Status block	Yes, up to 2 at the same time	
Single step	Yes	
• Number of breakpoints	4	
Diagnostic buffer		
• Available	Yes	
• Maximum number of entries (not configurable)	500	
• Configurable	No	
• Of which are power-failure-proof	100, only the last 100 entries are retentive	
• Maximum number of entries that can be read in RUN	499	
• Number of entries that can be set in RUN	Yes, from 10 to 499	
• Number of preset entries in RUN	10	
Service data		
• Can be read out	Yes	
Monitoring functions	CPU 313C-2 PtP	CPU 313C-2 DP
• Status LEDs	Yes	
Communication functions	CPU 313C-2 PtP	CPU 313C-2 DP
PG/OP communication	Yes	Yes
Prioritized OCM communication		
• Supported	No	
Routing	No	Yes
• Number of routing connections	-	Max. 4
• Data record routing	No	Yes

Technical specifications		CPU 313C-2 PtP	CPU 313C-2 DP
Global data communication			
• Supported		Yes	
• Number of GD circles, max.		8	
• Number of GD packets, max.		8	
• Number of GD packets, sender, max.		8	
• Number of GD packets, receiver, max.		8	
• Size of GD packets, max.		22 bytes	
• Size of GD packets, of those consistent, max.		22 bytes	
S7 basic communication			
• Supported		Yes	
• User data per job, max.		76 bytes	
• User data per job, consistent, max.		76 bytes (for X_SEND or X_RCV) 64 bytes (for X_PUT or X_GET as the server)	
S7 communication			
• Supported		Yes	
• As server		Yes	
• As client		Yes, via CP and loadable FBs	
• User data per job, max.		180 bytes for PUT/GET	
• User data per job, consistent, max.		240 bytes (as server)	
S5-compatible communication			
• Supported		Yes, via CP and loadable FCs	
Number of connections			
• Total		8	
Suitable for PG communication			
• PG communication, reserved		1	
• PG communication, configurable, min.		1	
• PG communication, configurable, max.		7	
Suitable for OP communication			
• OP communication, reserved		1	
• OP communication, configurable, min.		1	
• OP communication, configurable, max.		7	

Technical specifications		
	CPU 313C-2 PtP	CPU 313C-2 DP
Suitable for S7 basic communication	4	
• S7 basic communication, reserved	0	
• S7 basic communication, configurable, min.	0	
• S7 basic communication, configurable, max.	4	
Connection system		
• Required front connector	1 X 40-pin	
Interfaces	CPU 313C-2 PtP	CPU 313C-2 DP
1st interface		
Interface designation	X1	
Type of interface	Integrated RS 485 interface	
Hardware	RS 485	
• electrically disconnected	No	
• Interface power supply (15 V DC to 30 V DC), max.	200 mA	
Functionality		
• MPI	Yes	
• DP master	No	
• DP slave	No	
• Point-to-point connection	No	
MPI		
Services		
• PG/OP communication	Yes	
• Routing	No	Yes
• Global data communication	Yes	
• S7 basic communication	Yes	
• S7 communication	Yes (only server; connection configured at one end)	
• S7 communication, as client	No (but via CP and loadable FBs)	
• S7 communication, as server	Yes	
Transmission rate, max.	187.5 kbps	

Technical specifications		
	CPU 313C-2 PtP	CPU 313C-2 DP
2nd interface		
Interface designation	X2	
Type of interface	Integrated RS 422/485 interface	Integrated RS 485 interface
Hardware	RS 422/485	RS 485
• electrically disconnected	Yes	Yes
• Interface power supply (15 V DC to 30 V DC), max.	No	200 mA
Functionality		
• MPI	No	No
• DP master	No	Yes
• DP slave	No	Yes
• PROFINET IO controller	No	No
• PROFINET IO device	No	No
• PROFINET CBA	No	No
• Point-to-point connection	Yes	No
DP master		
Services		
• PG/OP communication	-	Yes
• Routing	-	Yes
• Global data communication	-	No
• S7 basic communication	-	Yes (intelligent blocks only)
• S7 communication	-	Yes (only server; connection configured at one end)
• S7 communication, as client	-	No
• S7 communication, as server	-	Yes
• Constant bus cycle time supported	-	Yes
• Isochronous mode	-	No
• SYNC/FREEZE	-	Yes
• Activate/deactivate DP slaves – Max. number of DP slaves that can be enabled / disabled simultaneously	-	Yes 8
• Direct data exchange (cross-traffic)	-	Yes, as subscriber
• DPV1	-	Yes
Transmission rate, max.	-	Up to 12 mbps

Technical specifications		
	CPU 313C-2 PtP	CPU 313C-2 DP
Number of DP slaves, max.	-	124
Address range		
• Inputs, max.	-	2 KB
• Outputs, max.	-	2 KB
User data per DP slave		
• Inputs, max.	-	244 bytes
• Outputs, max.	-	244 bytes
DP slave		
Services		
• PG/OP communication	-	Yes
• Routing	-	Yes (only if interface is active)
• Global data communication	-	No
• S7 basic communication	-	No
• S7 communication	-	Yes (only server; connection configured at one end)
• S7 communication, as client	-	No
• S7 communication, as server	-	Yes
• Direct data exchange (cross-traffic)	-	Yes
• DPV1	-	No
Transmission rate, max.	-	12 mbps
Automatic baud rate detection	-	Yes (only if interface is passive)
GSD file	-	The current GSD file is available for download at GSD file http://www.siemens.com/profibus-gsd
Transfer memory		
• Inputs, max.	-	244 bytes
• Outputs, max.	-	244 bytes
• Address areas, max.	-	32
• User data per address range, max.	-	32 bytes

Technical specifications		
	CPU 313C-2 PtP	CPU 313C-2 DP
Point-to-point connection		
• Transmission rates	38.4kbps half duplex 19.2 kbps full duplex	-
• Max. cable length	1200 m	-
• The user program can control the interface	Yes	-
• The interface can trigger an alarm or interrupt in the user program	Yes (message with break ID)	-
• Protocol driver	3964 (R); ASCII	-
Programming		
Programming language		
• LAD	Yes	
• FBD	Yes	
• STL	Yes	
• SCL	Yes	
• CFC	Yes	
• GRAPH	Yes	
• HiGraph®	Yes	
Instruction set		
• Nesting levels	8	
Know-how protection		
• User program/ password security	Yes	
• Block encryption	Yes, using S7-Block Privacy	
System functions (SFC)		
System function blocks (SFB)	See instruction list	
Integrated inputs/outputs		
Default addresses of the integrated		
Digital inputs	124.0 to 125.7	
Digital outputs	124.0 to 125.7	

Technical specifications		
	CPU 313C-2 PtP	CPU 313C-2 DP
Integrated functions		
• Number of counters	3 (see the manual <i>Technological Functions</i>)	
• Number of frequency meters	3 channels up to 30 kHz (see the manual <i>Technological Functions</i>)	
• Number of pulse outputs	3, pulse width modulations up to 2.5 kHz (see the manual <i>Technological Functions</i>)	
• Period measurement	3 channels (see the manual <i>Technological Functions</i>)	
• Open-loop positioning	No	
• Integrated function blocks (rules)	PID controller (see the manual <i>Technological Functions</i>)	
Dimensions		
	CPU 313C-2 PtP	CPU 313C-2 DP
• Mounting dimensions W x H x D (mm)	80 x 125 x 130	
• Weight, approx.	500 g	
Voltages and currents		
	CPU 313C-2 PtP	CPU 313C-2 DP
• Power supply (rated value)	24 V DC	
• Low limit of admissible range (DC)	19.2 V	
• High limit of admissible range (DC)	28.8 V	
• Current consumption (open-circuit), typically	110 mA	
• Inrush current, typ.	5 A	
• Current consumption (rated value)	580 mA	800 mA
• I ² t	0.7 A ² s	
• External protection of power supply lines (recommended)	MCB type C: Min. 2 A MCB Type B: Min. 4 A	
• Power loss, typically	9 W	

Reference

In the chapter *Technical specifications of the integrated I/O* you can find:

- the technical specifications of integrated I/Os under *Digital inputs of CPUs 31xC* and *Digital outputs of CPUs 31xC*.
- the block diagrams of the integrated I/Os under *Arrangement and use of integrated I/Os*.

8.5 CPU 314C-2 PtP and CPU 314C-2 DP

Technical specifications

Table 8- 6 Technical specifications of CPU 314C-2 PtP and CPU 314C-2 DP

Technical specifications		
	CPU 314C-2 PtP	CPU 314C-2 DP
CPU and version	CPU 314C-2 PtP	CPU 314C-2 DP
• MLFB	6ES7314-6BH04-0AB0	6ES7314-6CH04-0AB0
• Hardware version	01	01
• Firmware version	V3.3	V3.3
• Associated programming package	STEP 7 as of V5.5 + SP1 or STEP 7 as of V5.3 + SP2 with HSP 204	STEP 7 as of V5.5 + SP1 or STEP 7 as of V5.3 + SP2 with HSP 203
Memory	CPU 314C-2 PtP	CPU 314C-2 DP
Main memory		
• Integrated	192 KB	
• Expandable	No	
• Maximum size of non-volatile memory for retentive data blocks	64 KB	
Load memory		
• Pluggable (MMC)	Yes	
• Pluggable (MMC), max.	8 MB	
• Data retention on the Micro Memory Card (after the last programming action), min.	10 years	
Backup		
• Available	Yes (ensured with SIMATIC Micro Memory Card - maintenance-free)	
• Without battery	Yes (program and data)	
Execution times	CPU 314C-2 PtP	CPU 314C-2 DP
• For bit operation, min.	0.06 µs	
• For word operations, min.	0.12 µs	
• For fixed-point arithmetic, min.	0.16 µs	
• Minimum for floating-point arithmetic	0.59 µs	

Technical specifications		
	CPU 314C-2 PtP	CPU 314C-2 DP
Timers/counters and their retentivity	CPU 314C-2 PtP	CPU 314C-2 DP
S7 counters		
• Number	256	
Retentivity		
• Configurable	Yes	
• Default	From C 0 to C 7	
Counting range		
• Low limit	0	
• High limit	999	
IEC counter		
• Available	Yes	
• Type	SFB	
• Number	Unlimited (limited only by main memory size)	
S7 timers		
• Number	256	
Retentivity		
• Configurable	Yes	
• Default	No retentivity	
Time setting range		
• Low limit	10 ms	
• High limit	9990 s	
IEC timer		
• Available	Yes	
• Type	SFB	
• Number	Unlimited (limited only by main memory size)	
Data areas and their retentivity	CPU 314C-2 PtP	CPU 314C-2 DP
Bit memory		
• Number, max.	256 bytes	
• Retentivity, available	Yes (MB 0 to MB 255)	
• Retentivity, default	MB 0 to MB 15	
• Number of clock memories	8 (1 memory byte)	

Technical specifications		
	CPU 314C-2 PtP	CPU 314C-2 DP
Data blocks		
• Number, max.	1024 (in the number range 1 to 16000)	
• Size, max.	64 KB	
• Retentivity, configurable	Yes, via non-retain feature on the DB	
• Retentivity, default	Yes	
Local data		
• Per priority class, max.	32 KB, max. 2048 bytes per block	
Blocks		
• Number of blocks (total)	1024 (DBs, FCs, FBs) The maximum number of blocks that can be loaded may be reduced if you are using another MMC.	
OB		
• Size, max.	64 KB	
• Number of free cycle OBs	1 (OB 1)	
• Number of time-of-day interrupt OBs	1 (OB 10)	
• Number of time-delay interrupt OBs	2 (OB 20, 21)	
• Number of cyclic interrupt OBs	4 (OB 32, 33, 34, 35)	
• Number of hardware interrupt OBs	1 (OB 40)	
• Number of DPV1 interrupt OBs	-	3 (OB 55, 56, 57)
• Number of restart OBs	1 (OB 100)	
• Number of asynchronous error OBs	4 (OB 80, 82, 85, 87)	5 (OB 80, 82, 85, 86, 87)
• Number of synchronous error OBs	2 (OB 121, 122)	
Nesting depth		
• Per priority class	16	
• Additionally within an error OB	4	
FB		
• Number, max.	1024 (in the number range 0 to 7999)	
• Size	64 KB	
FC		
• Number, max.	1024 (in the number range 0 to 7999)	
• Size	64 KB	

Technical specifications		
	CPU 314C-2 PtP	CPU 314C-2 DP
Address ranges (inputs/outputs)	CPU 314C-2 PtP	CPU 314C-2 DP
I/O address area		
• Inputs	1024 bytes (freely addressable)	2048 bytes (freely addressable)
• Outputs	1024 bytes (freely addressable)	2048 bytes (freely addressable)
Distributed		
• Inputs	-	2003 bytes
• Outputs	-	2010 bytes
I/O process image		
• Inputs	1024 bytes	2048 bytes
• Outputs	1024 bytes	2048 bytes
• Inputs, adjustable	1024 bytes	2048 bytes
• Outputs, adjustable	1024 bytes	2048 bytes
• Inputs, preset	128 bytes	
• Outputs, preset	128 bytes	
Digital channels		
• Integrated channels (DI)	24	
• Integrated channels (DO)	16	
• Inputs	1016	16048
• Outputs	1008	16096
• Inputs, of those central	1016	
• Outputs, of those central	1008	
Analog channels		
• Integrated channels (AI)	5 (4 x current/voltage, 1 x resistance)	
• Integrated channels (AO)	2	
• Inputs	253	1006
• Outputs	250	1007
• Inputs, of those central	253	
• Outputs, of those central	250	
Hardware configuration	CPU 314C-2 PtP	CPU 314C-2 DP
• Racks, max.	4	
• Modules per rack, max.	8; max. 7 in rack ER 3	

Technical specifications		
	CPU 314C-2 PtP	CPU 314C-2 DP
Number of DP masters		
• Integrated	-	1
• Via CP	4	4
Number of usable FMs and CPs (recommended)		
• FM	8	
• CP, point-to-point	8	
• CP, LAN	10	
Time	CPU 314C-2 PtP	CPU 314C-2 DP
Clock		
• Hardware clock (real-time)	Yes	
• Buffered, can be synchronized	Yes	
• Factory setting	DT#1994-01-01-00:00:00	
• Buffered period	Typically 6 weeks (at an ambient temperature of 40 °C)	
• Behavior of the real-time clock after POWER OFF POWER ON	The clock continues running after POWER OFF	
• Behavior after expiration of the buffered period	The clock continues at the time of day it had when power was switched off.	
• Daily deviation	10 s, typ.: 2 s	
Runtime meter		
• Number	1	
• Number/number range	0	
• Range of values	0 to 2 ³¹ hours (if SFC 101 is used)	
• Granularity	1 hour	
• Retentive	Yes; must be manually restarted after every restart	
Clock synchronization		
• Supported	Yes	
• On MPI, master	Yes	
• On MPI, slave	Yes	
• On the AS, master	Yes	
• On the AS, slave	No	
• On DP, master	-	Yes, DP slave must be time slave
• On DP, slave	-	Yes

Technical specifications		
	CPU 314C-2 PtP	CPU 314C-2 DP
S7 signaling functions		
	CPU 314C-2 PtP	CPU 314C-2 DP
• Number of stations that can be logged on for signaling functions (e.g. OS)	12 (depends on the number of connections configured for PG/OP and S7 basic communication)	
• Process error diagnostic messages	Yes	
• Simultaneously enabled interrupt S blocks, max.	300	
Test and startup functions		
	CPU 314C-2 PtP	CPU 314C-2 DP
Status/modify		
• Status/modify variable	Yes	
• Variables	Inputs, outputs, bit memories, DBs, timers, counters	
• Maximum number of variables	30	
• Status variables, max.	30	
• Modify variables, max.	14	
Forcing		
• Forcing	Yes	
• Variables	Inputs, outputs	
• Maximum number of tags	10	
Status block	Yes, up to 2 at the same time	
Single step	Yes	
• Number of breakpoints	4	
Diagnostic buffer		
• Available	Yes	
• Maximum number of entries	500	
• Configurable	No	
• Of which are power-failure-proof	100, only the last 100 entries are retentive	
• Maximum number of entries that can be read in RUN	499	
• Number of entries that can be set in RUN	Yes, from 10 to 499	
• Number of preset entries in RUN	10	
Service data		
• Can be read out	Yes	
Monitoring function		
• Status LEDs	Yes	

Technical specifications		
	CPU 314C-2 PtP	CPU 314C-2 DP
Communication functions	CPU 314C-2 PtP	CPU 314C-2 DP
PG/OP communication	Yes	
Prioritized OCM communication		
• Supported	No	
Routing	No	Yes
• Number of routing connections	-	Max. 4
• Data record routing	No	Yes
Global data communication		
• Supported	Yes	
• Number of GD circles, max.	8	
• Number of GD packets, max.	8	
• Number of GD packets, sender, max.	8	
• Number of GD packets, receiver, max.	8	
• Number of GD packets, max.	22 bytes	
• Size of GD packets, of those consistent, max.	22 bytes	
S7 basic communication		
• Supported	Yes	
• User data per job, max.	76 bytes	
• User data per job, consistent, max.	76 bytes (for X_SEND or X_RCV) 64 bytes (for X_PUT or X_GET as the server)	
S7 communication		
• Supported	Yes	
• As server	Yes	
• As client	Yes (via CP and loadable FBs)	
• User data per job, max.	180 bytes (with PUT/GET)	
• User data per job, consistent, max.	240 bytes (as server)	
S5-compatible communication		
• Supported	Yes (via CP and loadable FCs)	
Number of connections		
• Total	12	
Suitable for PG communication		
• PG communication, reserved	1	
• PG communication, configurable, min.	1	
• PG communication, configurable, max.	11	

Technical specifications		
	CPU 314C-2 PtP	CPU 314C-2 DP
Suitable for OP communication	11	
• OP communication, reserved	1	
• OP communication, configurable, min.	1	
• OP communication, configurable, max.	11	
Suitable for S7 basic communication	8	
• S7 basic communication, reserved	0	
• S7 basic communication, configurable, min.	0	
• S7 basic communication, configurable, max.	8	
Connection system		
• Required front connector	2 X 40-pin	
Interfaces	CPU 314C-2 PtP	CPU 314C-2 DP
1st interface		
Interface designation	X1	
Type of interface	Integrated RS 485 interface	
Hardware	RS 485	
• Electrically isolated	No	
• Interface power supply (15 V DC to 30 V DC), max.	200 mA	
Functionality		
• MPI	Yes	
• DP master	No	
• DP slave	No	
• Point-to-point connection	No	
MPI		
Services		
• PG/OP communication	Yes	
• Routing	No	Yes
• Global data communication	Yes	
• S7 basic communication	Yes	
• S7 communication	Yes (only server; connection configured at one end)	
• S7 communication, as client	No (but via CP and loadable FBs)	
• S7 communication, as server	Yes	
• Transmission rate, max.	187.5 kbps	

Technical specifications		
	CPU 314C-2 PtP	CPU 314C-2 DP
2nd interface	CPU 314C-2 PtP	CPU 314C-2 DP
Interface designation	X2	
Type of interface	Integrated RS 422/485 interface	Integrated RS 485 interface
Hardware	RS 422/485	RS 485
• Electrically isolated	Yes	Yes
• Interface power supply (15 V DC to 30 V DC), max.	No	200 mA
Functionality		
• MPI	No	
• DP master	No	Yes
• DP slave	No	Yes
• PROFINET IO controller	No	
• PROFINET IO device	No	
• PROFINET CBA	No	
• Point-to-point connection	Yes	No
DP master		
Services		
• PG/OP communication	-	Yes
• Routing	-	Yes
• Global data communication	-	No
• S7 basic communication	-	Yes (intelligent blocks only)
• S7 communication	-	Yes (only server; connection configured at one end)
• S7 communication, as client	-	No
• S7 communication, as server	-	Yes
• Constant bus cycle time supported	-	Yes
• Isochronous mode	-	No
• SYNC/FREEZE	-	Yes
• Activate/deactivate DP slaves	-	Yes
– Max. number of DP slaves that can be enabled / disabled simultaneously	-	8
• Direct data exchange (cross-traffic)	-	Yes, as subscriber
• DPV1	-	Yes

Technical specifications		
	CPU 314C-2 PtP	CPU 314C-2 DP
Transmission rate, max.	-	Up to 12 mbps
Number of DP slaves, max.	-	124
Address range		
• Inputs, max.	-	2 KB
• Outputs, max.	-	2 KB
User data per DP slave		
• Inputs, max.	-	244 bytes
• Outputs, max.	-	244 bytes
DP slave		
Services		
• PG/OP communication	-	Yes
• Routing	-	Yes (only if interface is active)
• Global data communication	-	No
• S7 basic communication	-	No
• S7 communication	-	Yes (only server; connection configured at one end)
• S7 communication, as client	-	No
• S7 communication, as server	-	Yes
• Direct data exchange (cross-traffic)	-	Yes
• DPV1	-	No
Transmission rate, max.	-	Up to 12 mbps
Automatic baud rate detection	-	Yes (only if interface is passive)
GSD file	-	The current GSD file is available for download at GSD file (http://www.siemens.com/profibus-gsd)
Transfer memory		
• Inputs, max.	-	244 bytes
• Outputs, max.	-	244 bytes
• Address areas, max.	-	32
• User data per address range, max.	-	32 bytes

Technical specifications		
	CPU 314C-2 PtP	CPU 314C-2 DP
Point-to-point connection		
• Transmission rates	38.4kbps half duplex 19.2kbps full duplex	-
• Max. cable length	1200 m	-
• The user program can control the interface	Yes	-
• The interface can trigger an alarm or interrupt in the user program	Yes (message with break ID)	-
• Protocol driver	3964 (R); ASCII and RK512	-
Programming		
Programming language		
• LAD	Yes	
• FBD	Yes	
• STL	Yes	
• SCL	Yes	
• CFC	Yes	
• GRAPH	Yes	
• HiGraph®	Yes	
Instruction set		
• Nesting levels	8	
Know-how protection		
• User program/ password security	Yes	
• Block encryption	Yes, using S7-Block Privacy	
System functions (SFC)		
System function blocks (SFB)	See instruction list	
Integrated inputs/outputs		
Default addresses of the integrated		
Digital inputs	124.0 to 126.7	
Digital outputs	124.0 to 125.7	
Analog inputs	752 to 761	
Analog outputs	752 to 755	

Technical specifications		
	CPU 314C-2 PtP	CPU 314C-2 DP
Integrated functions		
• Number of counters	4 (see the manual <i>Technological Functions</i>)	
• Number of frequency meters	4 channels up to 60 kHz (see the manual <i>Technological Functions</i>)	
• Number of pulse outputs	4, pulse width modulations up to 2.5 kHz (see the manual <i>Technological Functions</i>)	
• Period measurement	4 channels (see the manual <i>Technological Functions</i>)	
• Open-loop positioning	1 channel (see the manual <i>Technological Functions</i>)	
• Integrated function blocks (rules)	PID controller (see the manual <i>Technological Functions</i>)	
Dimensions		
	CPU 314C-2 PtP	CPU 314C-2 DP
• Mounting dimensions W x H x D (mm)	• 120 x 125 x 130	
• Weight, approx.	• 680 g	
Voltages and currents		
	CPU 314C-2 PtP	CPU 314C-2 DP
Power supply (rated value)	24 V DC	
• Low limit of admissible range (DC)	19.2 V	
• High limit of admissible range (DC)	28.8 V	
• Current consumption (open-circuit), typically	150 mA	
• Inrush current, typ.	5 A	
• Current consumption (rated value)	660 mA	880 mA
• I ² t	0.7 A ² s	
• External protection of power supply lines (recommended)	MCB type C min. 2 A, MCB type B min. 4 A	
• Power loss, typically	13 W	

Reference

In the chapter *Technical specifications of the integrated I/O* you can find:

- the technical specifications of integrated I/Os under *Digital inputs of CPUs 31xC* and *Digital outputs of CPUs 31xC*.
- the block diagrams of the integrated I/Os under *Arrangement and use of integrated I/Os*.

8.6 CPU 314C-2 PN/DP

Technical specifications

Table 8- 7 Technical specifications of the CPU 314C-2 PN/DP

Technical specifications	
CPU and version	
• MLFB	6ES7314-6EH04-0AB0
• Hardware version	01
• Firmware version	V3.3
• Associated programming package	STEP 7 as of V5.5 and HSP 191
Memory	
Main memory	
• Integrated	192 KB
• Expandable	No
• Maximum size of non-volatile memory for retentive data blocks	64 KB
Load memory	
• Pluggable (MMC)	Yes
• Pluggable (MMC), max.	8 MB
• Data retention on the Micro Memory Card (after the last programming action), min.	10 years
Backup	
• Available	Yes (ensured with Micro Memory Card - maintenance-free)
• Without battery	Yes (program and data)
Execution times	
• For bit operation, min.	0.06 μ s
• For word operations, min.	0.12 μ s
• For fixed-point arithmetic, min.	0.16 μ s
• Minimum for floating-point arithmetic	0.59 μ s
Timers/counters and their retentivity	
S7 counters	
• Number	256
Retentivity	
• Configurable	Yes
• Default	Z 0 to Z 7

Technical specifications	
Counting range	
• Low limit	0
• High limit	999
IEC counter	
• Available	Yes
• Type	SFB
• Number	Unlimited (limited only by main memory size)
S7 timers	
• Number	256
Retentivity	
• Configurable	Yes
• Default	No retentivity
Time setting range	
• Low limit	10 ms
• High limit	9990 s
IEC timer	
• Available	Yes
• Type	SFB
• Number	Unlimited (limited only by main memory size)
Data areas and their retentivity	
Bit memory	
• Number, max.	256 bytes
• Retentivity, available	Yes (from MB 0 to MB 255)
• Retentivity, default	MB 0 to MB 15
• Number of clock memories	8 (1 memory byte)
Data blocks	
• Number, max.	1024 (in the number range 1 to 16000)
• Size, max.	64 KB
• Retentivity, configurable	Yes, via non-retain feature on the DB
• Retentivity, default	Yes
Local data	
• Per priority class, max.	32 KB, max. 2048 KB per block

Technical specifications	
Blocks	
• Number of blocks (total)	1024 (DBs, FCs, FBs) The maximum number of blocks that can be loaded may be reduced due to the Micro Memory Card you are using.
OB	See instruction list
• Size, max.	64 KB
• Number of free cycle OBs	1 (OB 1)
• Number of time-of-day interrupt OBs	1 (OB 10)
• Number of time-delay interrupt OBs	2 (OB 20, 21)
• Number of cyclic interrupt OBs	4 (OB 32, 33, 34, 35)
• Number of hardware interrupt OBs	1 (OB 40)
• Number of DPV1 interrupt OBs	3 (OB 55, 56, 57)
• Number of isochronous interrupt OBs	1 (OB 61), only for PROFINET IO
• Number of restart OBs	1 (OB 100)
• Number of asynchronous error OBs	6 (OB 80, 82, 83, 85, 86, 87) (OB 83 for PROFINET IO)
• Number of synchronous error OBs	2 (OB 121, 122)
Nesting depth	
• Per priority class	16
• Additionally within an error OB	4
FB	See instruction list
• Number, max.	1024 (in the number range 0 to 7999)
• Size	64 KB
FC	See instruction list
• Number, max.	1024 (in the number range 0 to 7999)
• Size	64 KB
Address ranges (inputs/outputs)	
I/O address area	
• Inputs	2048 bytes (freely addressable)
• Outputs	2048 bytes (freely addressable)
Distributed	
• Inputs	2003 bytes
• Outputs	2010 bytes
I/O process image	
• Inputs	2048 bytes

Technical specifications	
• Outputs	2048 bytes
• Inputs, adjustable	2048 bytes
• Outputs, adjustable	2048 bytes
• Inputs, preset	256 bytes
• Outputs, preset	256 bytes
Process image partitions	
• Number of process image partitions	1
• Amount of user data in the process image partition for isochronous PROFINET IO, max.	1600 bytes
Digital channels	
• Integrated channels (DI)	24
• Integrated channels (DO)	16
• Inputs	16048
• Outputs	16096
• Inputs, of those central	1016
• Outputs, of those central	1008
Analog channels	
• Integrated channels (AI)	5 (4 x current/voltage, 1 x resistance)
• Integrated channels (AO)	2
• Inputs	1006
• Outputs	1007
• Inputs, of those central	253
• Outputs, of those central	250
Hardware configuration	
• Racks, max.	4
• Modules per rack, max.	8, max. 7 in rack 3
Number of DP masters	
• Integrated	1
• Via CP	4
Number of usable FMs and CPs (recommended)	
• FM	8
• CP, point-to-point	8
• CP, LAN	10

Technical specifications	
Time	
Clock	
• Hardware clock (real-time)	Yes
• Buffered, can be synchronized	Yes
• Factory setting	DT#1994-01-01-00:00:00
• Buffered period	Typically 6 weeks (at an ambient temperature of 40 °C)
• Behavior of the real-time clock after POWER ON	The clock continues running after POWER OFF.
• Behavior of the clock on expiration of the buffered period	The clock continues at the time of day it had when power was switched off.
• Daily deviation	10 s, typ. 2 s
Runtime meter	
• Number	1
• Number/number range	0
• Range of values	0 to 2 ³¹ hours (using the SFC 101)
• Granularity	1 hour
• Retentive	Yes; must be manually restarted after every restart
Clock synchronization	
• Supported	Yes
• On the AS, master	Yes
• On the AS, slave	Yes
• On MPI, master	Yes
• On MPI, slave	Yes
• On DP, master	Yes (DP slave must be time slave)
• On DP, slave	Yes
• On Ethernet via NTP	Yes (as client)
S7 signaling functions	
• Number of stations that can be logged on for signaling functions, max.	12 (depends on the number of connections configured for PG/OP and S7 basic communication)
• Process error diagnostic messages	Yes
• Simultaneously enabled interrupt S blocks, max.	300

Technical specifications	
Test and startup functions	
Status/modify	
• Status/modify variable	Yes
• Variables	Inputs, outputs, bit memories, DBs, timers, counters
• Maximum number of variables	30
• Status variables, max.	30
• Modify variables, max.	14
Forcing	
• Forcing	Yes
• Variables	Inputs/outputs
• Maximum number of tags	10
Maximum number of status blocks	Yes, up to 2 at the same time
Single step	
• Number of breakpoints	4
Diagnostic buffer	
• Available	Yes
• No. of entries, max.	500
• Configurable	No
• Of which are power-failure-proof	100, only the last 100 entries are retentive
• Maximum number of entries that can be read in RUN	499
• Number of entries that can be set in RUN	Yes (from 10 to 499)
• Number of preset entries in RUN	10
Service data	
• Can be read out	Yes
Monitoring function	
• Status LEDs	Yes
Communication functions	
PG/OP communication	Yes
Prioritized OCM communication	No
Routing	
• Number of routing connections	X1 as MPI: max. 10; X1 as DP master: max. 24 X1 as DP slave (active): max. 14 X2 as PROFINET: Max. 24
• Data record routing	Yes

Technical specifications	
Global data communication	
• Supported	Yes
• Number of GD circles, max.	8
• Number of GD packages, max.	8
• Number of GD packages, sender, max.	8
• Number of GD packages, receiver, max.	8
• Size of GD packages, max.	22 bytes
• Size of GD packages, of those consistent, max.	22 bytes
S7 basic communication	
• Supported	Yes
• User data per job, max.	76 bytes
• User data per job, consistent, max.	76 Bytes (for X-SEND/REC), 64 bytes (for X-PUT/GET as server)
S7 communication	
• Supported	Yes
• As server	Yes
• As client	Yes (via integrated PN interface and loadable FBs, or via CP and loadable FBs)
• User data per job, max.	See the STEP 7 Online Help, <i>Common parameters of SFBs/FBs and SFC/FC of the S7 communication</i>
S5-compatible communication	
• Supported	Yes (via CP and loadable FCs)
Web server	
• Supported	Yes
• Number of HTTP clients	5
• User-defined web pages	Yes
Open IE communication	
• Supported	Yes
• Number of connections/access points, total	8
• Local port number used at the system end	0, 20, 21, 23, 25, 80, 102, 135, 161, 8080, 34962, 34963, 34964, 65532, 65533, 65535
TCP/IP	
• Maximum number of connections	8
• Data length for connection type 01 _H , max.	1460 bytes
• Data length for connection type 11 _H , max.	32768 bytes

Technical specifications	
• Multiple passive connections per port (multiport), supported	Yes
ISO on TCP (RFC1006)	Yes (via integrated PROFINET interface and loadable FBs)
• Maximum number of connections	8
• Data length, max.	32768 bytes
UDP	Yes (via integrated PROFINET interface and loadable FBs)
• Maximum number of connections	8
• Data length, max.	1472 bytes
iPAR server	
• Supported	Yes
Number of connections	
• Total	12
Suitable for PG communication	
• PG communication, reserved	1
• PG communication, configurable, min.	1
• PG communication, configurable, max.	11
Suitable for OP communication	
• OP communication, reserved	1
• OP communication, configurable, min.	1
• OP communication, configurable, max.	11
Suitable for S7 basic communication	
• S7 basic communication, reserved	0
• S7 basic communication, configurable, min.	0
• S7 basic communication, configurable, max.	8
Suitable for S7 communication	
• S7 communication, reserved	0
• S7 communication, configurable, min.	0
• S7 communication, configurable, max.	10
Total number of instances, max.	32
PROFINET CBA (with communication load setpoint)	
• Reference setting for CPU communication	50 %
• Number of remote interconnecting partners	32
• Number of master/slave functions	30
• Total of all master/slave connections	1000

Technical specifications	
• Data length of all incoming master/slave connections, max.	4000 bytes
• Data length of all outgoing master/slave connections, max.	4000 bytes
• Number of device-internal and PROFIBUS interconnections	500
• Data length of the device-internal and PROFIBUS interconnections, max.	4000 bytes
• Data length per connection, max.	1400 bytes
Remote interconnections with acyclic transmission	
• Sampling rate: Sampling time, min.	500 ms
• Number of incoming interconnections	100
• Number of outgoing interconnections	100
• Data length of all incoming interconnections, max.	2000 bytes
• Data length of all outgoing interconnections, max.	2000 bytes
• Data length per connection (acyclic interconnections), max.	1400 bytes
Remote interconnections with cyclic transmission	
• Transmission frequency: Minimum transmission interval	10 ms
• Number of incoming interconnections	200
• Number of outgoing interconnections	200
• Data length of all incoming interconnections, max.	2000 bytes
• Data length of all outgoing interconnections, max.	2000 bytes
• Data length per connection (acyclic interconnections), max.	450 bytes
HMI variables via PROFINET (acyclic)	
• HMI variables update	500 ms
• Number of stations that can be logged on for HMI variables (PN OPC/iMAP)	3, 2xPN OPC/1x iMAP
• Number of HMI variables	200
• Data length of all HMI variables, max.	2000 bytes
PROFIBUS proxy functionality	
• Supported	Yes

Technical specifications	
• Number of coupled PROFIBUS devices	16
• Data length per connection, max.	240 bytes (slave dependent)
Interfaces	
1st interface	
Interface designation	X1
Type of interface	Integrated RS 485 interface
Hardware	RS 485
• electrically disconnected	Yes
• Interface power supply (15 V DC to 30 V DC), max.	200 mA
Functionality	
• MPI	Yes
• DP master	Yes
• DP slave	Yes
• PROFINET IO device	No
• PROFINET IO controller	No
• PROFINET CBA	No
• Open IE communication	No
• Web server	No
• Point-to-point connection	No
MPI	
Services	
• PG/OP communication	Yes
• Routing	Yes
• Global data communication	Yes
• S7 basic communication	Yes
• S7 communication	Yes (server only, connections configured at one end)
• S7 communication, as client	No (but via CP and loadable FBs)
• S7 communication, as server	Yes
Transmission rate, max.	12 Mbps
DP master	
Services	
• PG/OP communication	Yes
• Routing	Yes
• Global data communication	No

Technical specifications	
• S7 basic communication	Yes (only I blocks)
• S7 communication	Yes (server only, connections configured at one end)
• Constant bus cycle time supported	Yes
• Isochronous mode	No
• SYNC/FREEZE	Yes
• Activation/deactivation of DP slaves – Max. number of DP slaves that can be enabled / disabled simultaneously	Yes 8
• Direct data exchange (cross-traffic)	Yes (as subscriber)
• DPV1	Yes
Transmission rate, max.	12 Mbps
Number of DP slaves, max.	124
Address range	
• Inputs, max.	2 KB
• Outputs, max.	2 KB
User data per DP slave	
• Inputs, max.	244 bytes
• Outputs, max.	244 bytes
DP slave	
Services	
• PG/OP communication	Yes
• Routing	Yes (only if interface is active)
• Global data communication	No
• S7 basic communication	No
• S7 communication	Yes (only server; connection configured at one end)
• Direct data exchange (cross-traffic)	Yes
• DPV1	No
Transmission rate, max.	12 Mbps
Automatic baud rate detection	Yes (only if interface is passive)
Transfer memory	
• Inputs	244 bytes
• Outputs	244 bytes
• Address range, max.	32
• User data per address range, max.	32 bytes

Technical specifications	
GSD file	The current GSD file is available for download from the Internet (http://www.siemens.com/profibus-gsd).
2nd interface	
Interface designation	X2
Type of interface	PROFINET
Hardware	Ethernet RJ 45
<ul style="list-style-type: none"> electrically disconnected 	Yes
<ul style="list-style-type: none"> Integrated switch 	Yes
<ul style="list-style-type: none"> Number of ports 	2
<ul style="list-style-type: none"> Automatic determination of the transmission rate 	Yes (10/100 Mbps)
<ul style="list-style-type: none"> Autonegotiation 	Yes
<ul style="list-style-type: none"> Autocrossing 	Yes
Media redundancy	
<ul style="list-style-type: none"> Supported 	Yes
<ul style="list-style-type: none"> Changeover time on line break, typically 	200 ms (PROFINET MRP)
<ul style="list-style-type: none"> Number of nodes on the ring, max. 	50
Change of the IP address at runtime, supported	Yes
Keep Alive function, supported	Yes
Functionality	
<ul style="list-style-type: none"> MPI 	No
<ul style="list-style-type: none"> DP master 	No
<ul style="list-style-type: none"> DP slave 	No
<ul style="list-style-type: none"> PROFINET IO controller 	Yes, even simultaneously with IO device functionality
<ul style="list-style-type: none"> PROFINET IO device 	Yes, even simultaneously with IO controller functionality
<ul style="list-style-type: none"> PROFINET CBA 	Yes (acyclic and cyclic transmission)
<ul style="list-style-type: none"> Open IE communication 	Yes; via TCP/IP, ISO on TCP, UDP
<ul style="list-style-type: none"> Web server – Number of HTTP clients 	Yes 5
PROFINET IO controller	
Services	
<ul style="list-style-type: none"> PG/OP communication 	Yes
<ul style="list-style-type: none"> Routing 	Yes
<ul style="list-style-type: none"> S7 communication 	Yes, with loadable FBs, max. configurable connections: 10, Maximum number of instances: 32

Technical specifications	
• Open IE communication	Yes; via TCP/IP, ISO on TCP, UDP
Number of integrated PROFINET IO controllers	1
RT, supported	Yes
IRT, supported	Yes
Transmission rate, max.	100 Mbps
Maximum number of connectable IO devices	128
Number of connectable IO devices, for RT, max.	128
• of which in line, max.	128
Number of IO devices with IRT and "high flexibility" option	128
• of which in line, max.	61
Number of IO devices with IRT and "high performance" option, max.	64
• of which in line, max.	64
Shared Device, supported	Yes
Isochronous mode	Yes, OB61
Prioritized startup, supported	Yes
• Maximum number of IO devices with prioritized startup	32
Activating/deactivating of PROFINET IO Devices	Yes
• Number of IO devices that can be enabled / disabled simultaneously, max.	8
IO devices changing during runtime (partner ports), supported	Yes
• Number of IO devices per tool, max.	8
Device replacement without removable medium	Yes
Send clocks	250 μ s, 500 μ s, 1 ms 2 ms, 4 ms (not for IRT with "high flexibility" option)
Update time	
• Update times	The minimum update time also depends on the time slice set for PROFINET IO communication, the number of IO Devices used, and on the amount of configured user data.
With RT	
• for send clock of 250 μ s	250 μ s to 128 ms
• for send clock of 500 μ s	500 μ s to 256 ms
• for send clock of 1 ms	1 ms to 512 ms
• for send clock of 2 ms	2 ms to 512 ms
• for send clock of 4 ms	4 ms to 512 ms

Technical specifications	
For IRT with "high flexibility" option	
• for send clock of 250 µs	250 µs to 128 ms
• for send clock of 500 µs	500 µs to 256 ms
• for send clock of 1 ms	1 ms to 512 ms
For IRT with "high performance" option	
• for send clock of 250 µs	250 µs to 4 ms
• for send clock of 500 µs	500 µs to 8 ms
• for send clock of 1 ms	1 ms to 16 ms
• for send clock of 2 ms	2 ms to 32 ms
• for send clock of 4 ms	4 ms to 64 ms
For IRT with "high performance" option and parameter assignment for "odd-numbered" send clocks	Update time = "odd-numbered" send clock set (any multiple of 125 µs: 375 µs, 625 µs to 3.875 ms)
Address range	
• Inputs, max.	2048 bytes
• Outputs, max.	2048 bytes
User data per address range, max.	
• User data consistency, max.	1024 bytes
PROFINET IO device	
Services	
• PG/OP communication	Yes
• Routing	Yes
• S7 communication	Yes, with loadable FBs, max. configurable connections: 10, Maximum number of instances: 32
• Open IE communication	Yes; via TCP/IP, ISO on TCP, UDP
RT, supported	Yes
IRT, supported	Yes
PROFenergy, supported	Yes, prepared with SFB 73 / 74 for loadable PROFenergy standard FBs for intelligent IO devices
Shared Device, supported	
• Number of IO controllers for shared devices, max.	2
Isochronous mode	No
Application transfer areas	Yes
IO devices transfer area	No

Technical specifications	
Transfer memory	
• Inputs, max.	1440 bytes, per controller for shared devices
• Outputs, max.	1440 bytes, per controller for shared devices
Submodules	
• Number, max.	64
• User data per submodule, max.	1024 bytes
Programming	
Programming language	
• LAD	Yes
• FBD	Yes
• STL	Yes
• SCL	Yes
• CFC	Yes
• GRAPH	Yes
• HiGraph®	Yes
Instruction set	
• Nesting levels	8
Know-how protection	
• User program/password security	Yes
• Encryption of blocks	Yes, using S7-Block Privacy
System functions (SFC)	
See instruction list	
System function blocks (SFB)	
See instruction list	
Integrated inputs/outputs	
Default addresses of the integrated	
Digital inputs	136 to 138
Digital outputs	136 to 137
Analog inputs	800 to 809
Analog outputs	800 to 803
Integrated functions	
• Number of counters	4 (see the Manual <i>Technological Functions</i>)
• Number of frequency meters	4 channels up to 60 kHz (see the Manual <i>Technological Functions</i>)
• Open-loop positioning	1 channel (see the Manual <i>Technological Functions</i>)
• Integrated function blocks (rules)	PID controller (see Manual <i>Technological Functions</i>)
• Number of pulse outputs	4 channels for pulse width modulation up to 2.5 kHz (see the Manual <i>Technological Functions</i>)

Technical specifications	
Dimensions	
• Mounting dimensions W x H x D (mm)	120 x 125 x 130
• Weight	730 g
Voltages and currents	
Power supply (rated value)	24 V DC
• Low limit of admissible range (DC)	19.2 V
• High limit of admissible range (DC)	28.8 V
• Current consumption (open-circuit), typically	190 mA
• Current consumption (rated value)	850 mA
• Inrush current, typ.	5 A
• I ² t	0.7 A ² s
• External protection of power supply lines (recommended), min.	MCB switch, Type C, min. 2 A; MCB switch, Type B, min. 4 A
• Power loss, typically	16 W

Reference

In the chapter *Technical specifications of the integrated I/O* you can find:

- the technical specifications of integrated I/Os under *Digital inputs of CPUs 31xC* and *Digital outputs of CPUs 31xC*.
- the block diagrams of the integrated I/Os under *Arrangement and use of integrated I/Os*.

8.7 Technical specifications of the onboard I/O

8.7.1 Arrangement and usage of integrated inputs/outputs

Introduction

The integrated inputs/outputs of the 31xC CPUs can be used for technological functions or as standard I/Os.

The figures below illustrate the possible usage of I/Os integrated in the CPUs.

Reference

Additional information on integrated I/Os can be found in the Manual *Technical Functions*.

CPU 312C: Pin assignment of the integrated DI/DO (connector X11)

Standard	Interrupt input	Counting	X11	
			Pin	Signal
			1	
DI	X	Z0 (A)	2	DI+0.0
DI	X	Z0 (B)	3	DI+0.1
DI	X	Z0 (HW-Tor)	4	DI+0.2
DI	X	Z1 (A)	5	DI+0.3
DI	X	Z1 (B)	6	DI+0.4
DI	X	Z1 (HW-Tor)	7	DI+0.5
DI	X	Latch 0	8	DI+0.6
DI	X	Latch 1	9	DI+0.7
DI	X		10	DI+1.0
	X		11	DI+1.1
			12	2M
			13	1L+
DO		V0	14	DO+0.0
DO		V1	15	DO+0.1
DO			16	DO+0.2
DO			17	DO+0.3
DO			18	DO+0.4
DO			19	DO+0.5
			20	1M

Zn Counter n
A, B Sensor signals
Vn Comparator n
X Pin can be used, provided it is not in use by technological functions
HW-Tor Gate control
Latch Save counter value

ماكان كنترول

Block diagram of the integrated digital I/Os

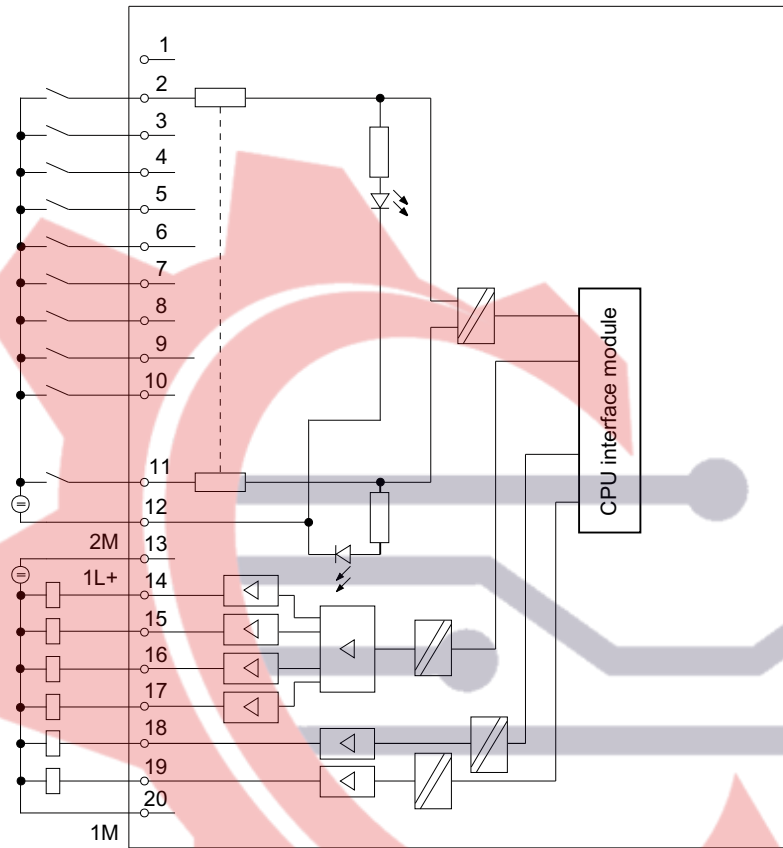

ماکان کنترول

CPU 313C, CPU 313C-2 DP/PtP, CPU 314C-2 DP/PtP, CPU 314C-2 PN/DP: DI/DO (connectors X11 and X12)

X11 of the CPU 313C-2 PtP, CPU 313C-2 DP
X12 of the CPU 313C, CPU 314C-2 PtP, CPU 314C-2 DP, CPU 314C-2 PN/DP

Standard DI	Interrupt input	Counting	Positioning 1)	Positioning 1)				digital	analog	Counting	Standard DO
				1 \emptyset	1L+	2L+	\emptyset 21				
X	X	Z0 (A)	A 0	2 \emptyset	DI+0.0	DO+0.0	\emptyset 22			V0	X
X	X	Z0 (B)	B 0	3 \emptyset	DI+0.1	DO+0.1	\emptyset 23			V1	X
X	X	Z0 (HW-Tor)	N 0	4 \emptyset	DI+0.2	DO+0.2	\emptyset 24			V2	X
X	X	Z1 (A)	Tast 0	5 \emptyset	DI+0.3	DO+0.3	\emptyset 25			V3 1)	X
X	X	Z1 (B)	Bero 0	6 \emptyset	DI+0.4	DO+0.4	\emptyset 26				X
X	X	Z1 (HW-Tor)		7 \emptyset	DI+0.5	DO+0.5	\emptyset 27				X
X	X	Z2 (A)		8 \emptyset	DI+0.6	DO+0.6	\emptyset 28		CONV_EN		X
X	X	Z2 (B)		9 \emptyset	DI+0.7	DO+0.7	\emptyset 29		CONV_DIR		X
				10 \emptyset		2M	\emptyset 30				
				11 \emptyset		3L+	\emptyset 31				
X	X	Z2 (HW-Tor)		12 \emptyset	DI+1.0	DO+1.0	\emptyset 32	R+			X
X	X	Z3 (A)		13 \emptyset	DI+1.1	DO+1.1	\emptyset 33	R-			X
X	X	Z3 (B)	1)	14 \emptyset	DI+1.2	DO+1.2	\emptyset 34	Rapid traverse			X
X	X	Z3 (HW-Tor)		15 \emptyset	DI+1.3	DO+1.3	\emptyset 35	Slow-action			X
X	X	Z0 (Latch)		16 \emptyset	DI+1.4	DO+1.4	\emptyset 36				X
X	X	Z1 (Latch)		17 \emptyset	DI+1.5	DO+1.5	\emptyset 37				X
X	X	Z2 (Latch)		18 \emptyset	DI+1.6	DO+1.6	\emptyset 38				X
X	X	Z3 (Latch)	1)	19 \emptyset	DI+1.7	DO+1.7	\emptyset 39				X
				20 \emptyset	1M	3M	\emptyset 40				

- Zn Counter n
 - A, B Encoder signals
 - HW gate Gate Control
 - Latch Save counter value
 - Vn Comparator n
 - Probe 0 Probe 0
 - Bero 0 Reference point switch 0
 - R+, R- Directional signal
 - Rapid traverse Rapid traverse
 - Slow-action Creep speed
 - CONV_EN Enable power unit
 - CONV_DIR Direction signal (only with control mode "voltage 0 to 10 V or current from 0 mA to 10 mA and direction signal")
 - X Pin can be used, provided it is not in use by technological functions
- 1) CPU 314C-2 only

Reference

Additional information can be found in the Manual *Technical Functions* under *Counting*, *Frequency Measurement* and *Pulse Width Modulation*

Block diagram of the integrated digital I/Os of the CPUs 313C/313C-2/314C-2

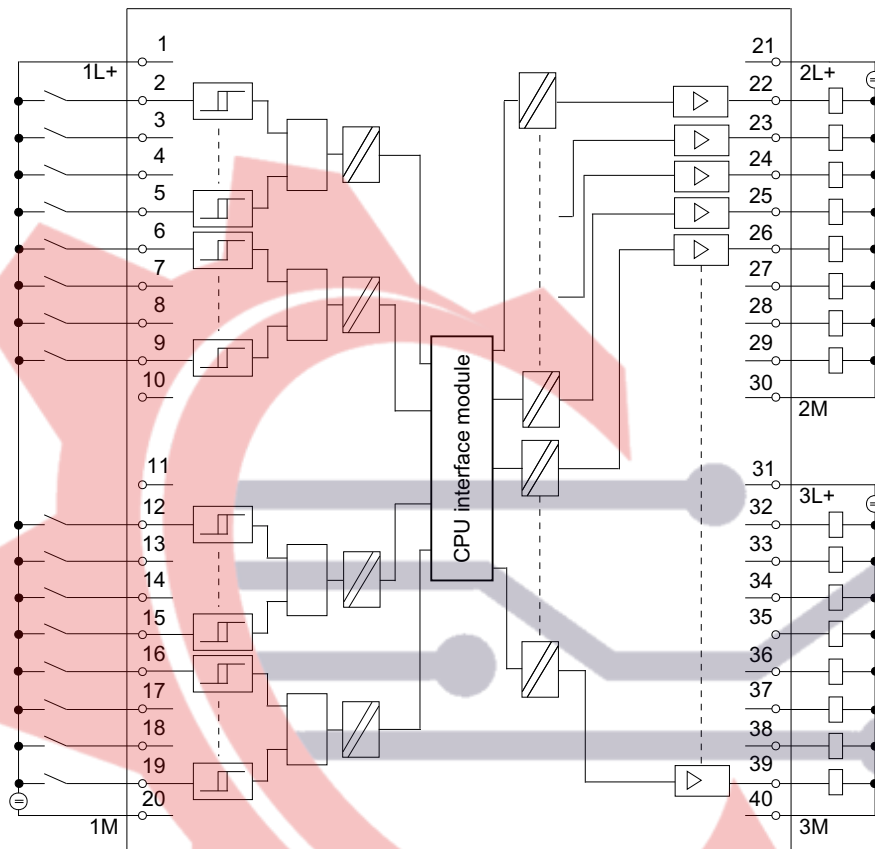

CPU 313C/314C-2: Pin-out of the integrated AI/AO and DI (connector X11)

Standard		Position		X11				Standard DI		Interrupt input	
		1)		1		Ø 21		Ø 21			
AI (Ch0)	V			2 Ø		DI+2.0	Ø 22	X		X	
	I		PEWx+0	3 Ø		DI+2.1	Ø 23	X		X	
	C			4 Ø		DI+2.2	Ø 24	X		X	
AI (Ch1)	V			5 Ø		DI+2.3	Ø 25	X		X	
	I		PEWx+2	6 Ø		DI+2.4	Ø 26	X		X	
	C			7 Ø		DI+2.5	Ø 27	X		X	
AI (Ch2)	V			8 Ø		DI+2.6	Ø 28	X		X	
	I		PEWx+4	9 Ø		DI+2.7	Ø 29	X		X	
	C			10 Ø		4M	Ø 30				
AI (Ch3)	V			11 Ø			Ø 31				
	I		PEWx+6	12 Ø			Ø 32				
	C			13 Ø			Ø 33				
PT 100 (Ch4)				14 Ø		PEWx+8	Ø 34				
				15 Ø			Ø 35				
AO (Ch0)	V	Manipulated value 0		16 Ø		PAWx+0	Ø 36				
	A			17 Ø			Ø 37				
AO (Ch1)	V			18 Ø		PAWx+2	Ø 38				
	A			19 Ø			Ø 39				
				20 Ø	M _{ANA}		Ø 40				

1) only CPU 314C-2

Block diagram of integrated digital/analog I/Os of the CPUs 313C/314C-2

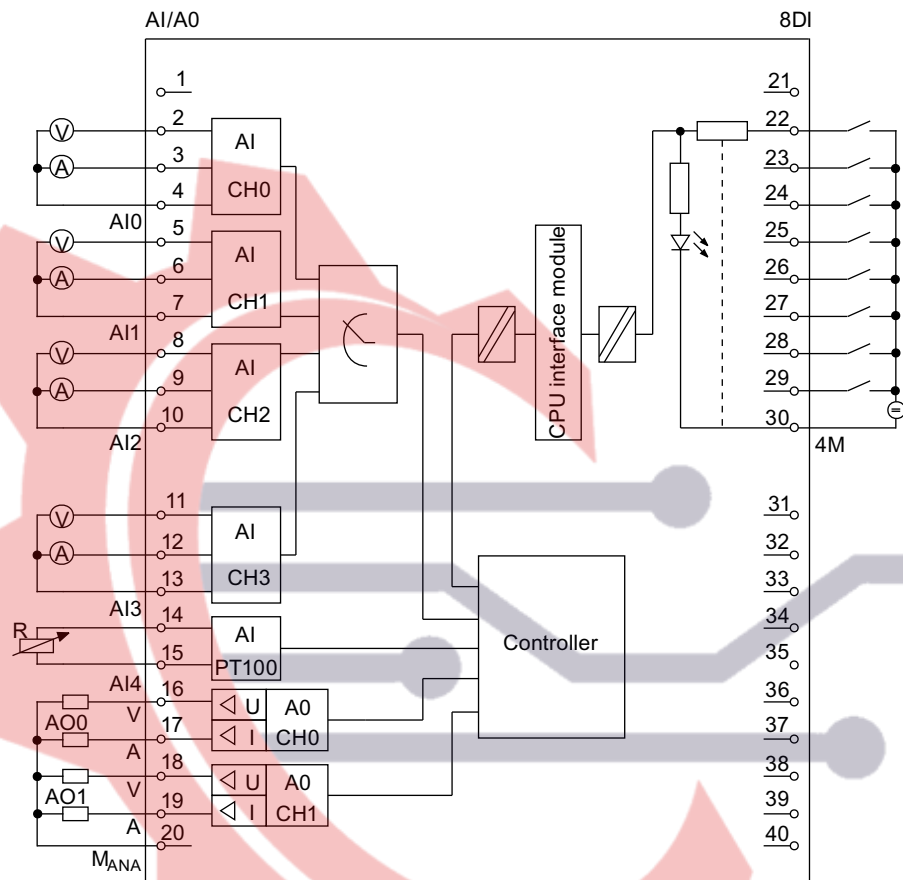

Simultaneous usage of technological functions and standard I/Os

Technological functions and standard I/Os can be used simultaneously with the appropriate hardware. For example, you can use all digital inputs not used for counting functions as standard DI.

Read access to inputs used by technological functions is possible. Write access to outputs used by technological functions is not possible.

See also

- CPU 312C (Page 215)
- CPU 313C (Page 224)
- CPU 313C-2 PtP and CPU 313C-2 DP (Page 233)
- CPU 314C-2 PtP and CPU 314C-2 DP (Page 245)
- CPU 314C-2 PN/DP (Page 257)

8.7.2 Analog I/O devices

Abbreviations used in the figures below

M	Ground connection
Mx+	Measuring line "+" (positive), for channel x
Mx-	Measuring line "-" (negative), for channel x
M _{ANA}	Reference potential of the analog measuring circuit
Al _{XU}	Voltage input "+" for channel x
Al _{XI}	Current input "+" for channel x
Al _{XC}	Common current and voltage input "-" for channel x
Al _x	Analog input channel x

Wiring of the current/voltage inputs

The figures below shows the wiring diagram of the current/voltage inputs operated with 2-/4-wire transducers.

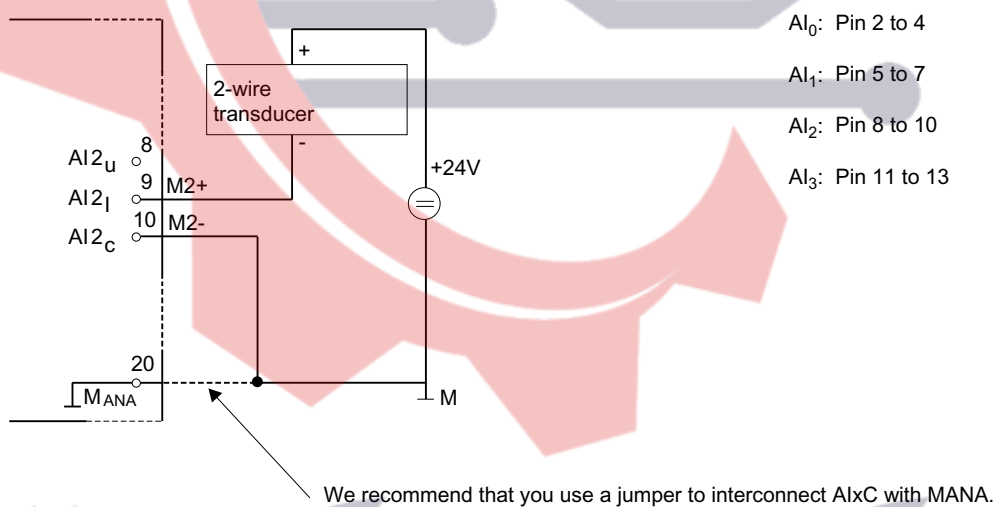

Figure 8-1 Connection of a 2-wire transducer to an analog current/voltage input of the CPU 313C/314C-2

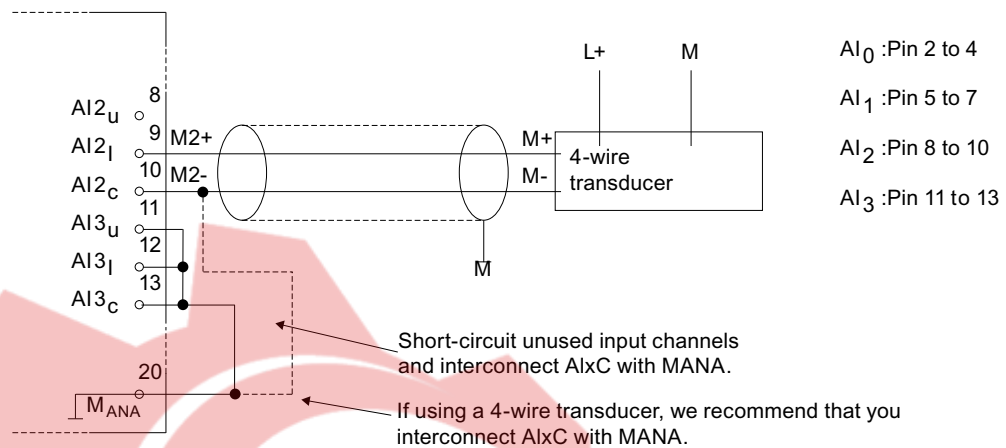

Figure 8-2 Connection of a 4-wire transducer to an analog current/voltage input of the CPU 313C/314C-2

Measuring principle

31xC CPUs use the measuring principle of actual value encoding. They operate with a sampling rate of 1 kHz. That is, a new value is available at the peripheral input word register once every millisecond and can then be read via the user program (e.g. L PEW). The "previous" value is read again if access times are shorter than 1 ms.

ماکان کنترول

Integrated hardware low-pass filter

The analog input signals of channels 0 to 3 pass through integrated low-pass filters. They are attenuated according to the trend in the figure below.

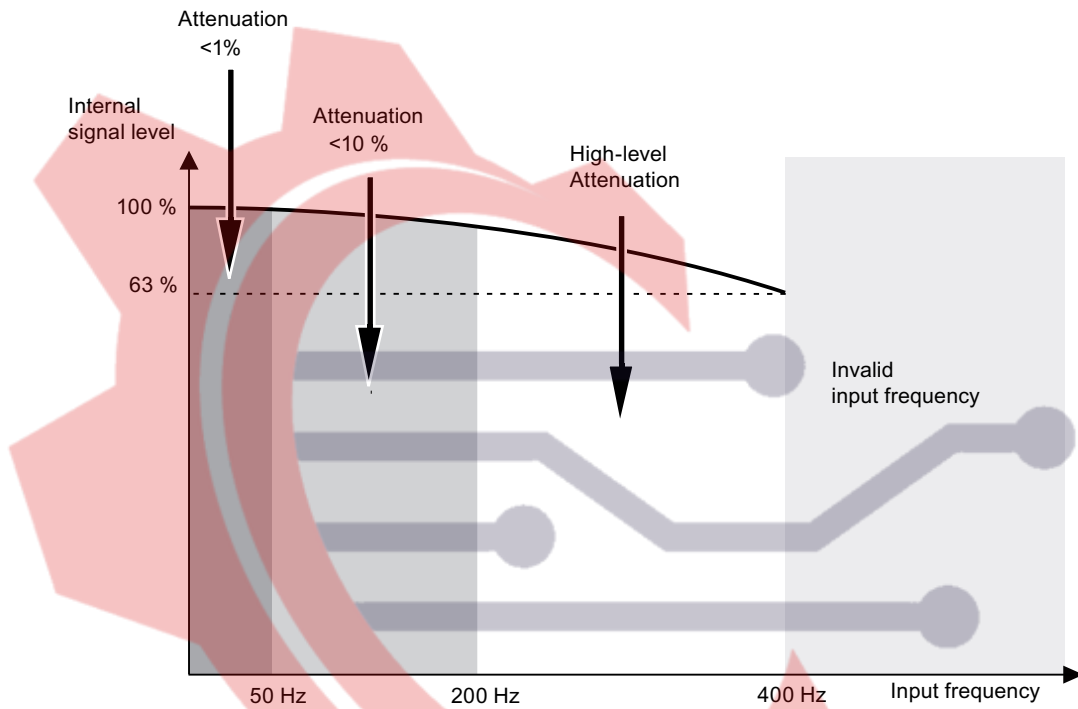

Figure 8-3 Low-pass characteristics of the integrated filter

Note

The maximum frequency of the input signal is 400 Hz.

ماکان کنترول

Input filters (software filter)

The current/voltage inputs have a software filter for the input signals which can be parameterized with STEP 7. It filters the parameterized interference frequency (50/60 Hz) and multiples thereof.

The selected interference frequency suppression also determines the integration time. With an interference frequency suppression of 50 Hz the software filter generates the mean value based on the last 20 measurements and saves the result as a measured value.

You can suppress interference frequencies (50 Hz or 60 Hz) according to the parameters set in STEP 7. The interference frequency suppression will not work with a setting of 400 Hz (software filter deactivated).

The analog input signals of channels 0 to 3 pass through integrated low-pass filters.

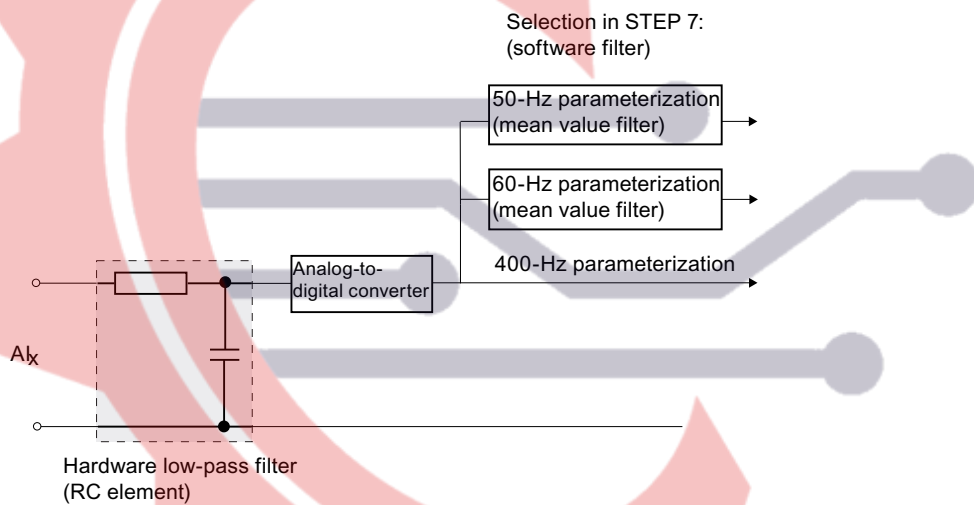

Figure 8-4 Principle of interference suppression with STEP 7

ماکان کنترول

The two graphics below illustrate the principle of operation of 50 Hz and 60 Hz interference frequency suppression

Example of a 50 Hz interference suppression (integration time corresponds to 20 ms)

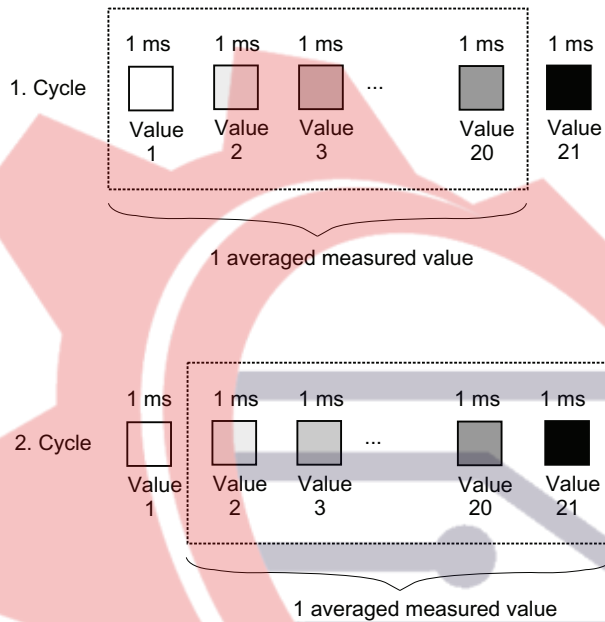

Figure 8-5 50 Hz interference frequency suppression

Example of a 60 Hz interference suppression (integration time corresponds to 16,7 ms)

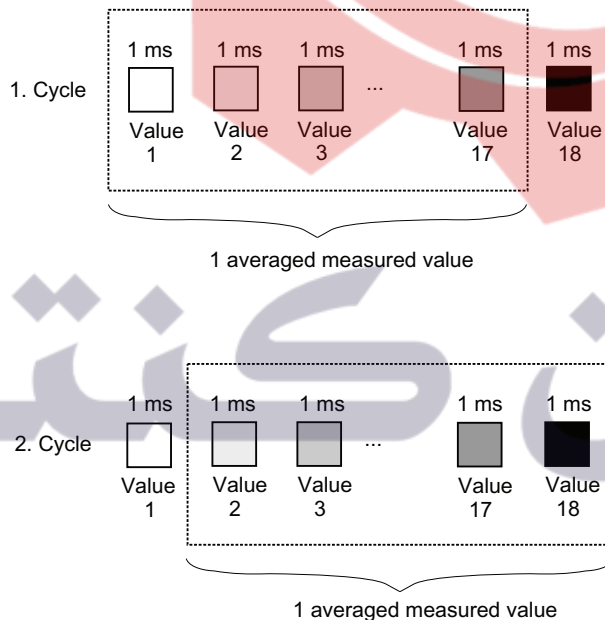

Figure 8-6 60 Hz interference frequency suppression

Note

If the interference frequency is not 50/60 Hz or a multiple thereof, the input signal must be filtered externally.

In this case, 400 Hz interference frequency suppression must be configured for the respective input. This is equivalent to a "deactivation" of the software filter.

Inputs not connected

The 3 inputs of a current/voltage analog output channel that is not connected should be bypasses and connected to M_{ANA} (pin 20 of the front connector). This ensures maximum interference immunity for these analog inputs.

Outputs not connected

In order to disconnect unused analog outputs from power, you must disable and leave them open during parameter assignment with STEP 7.

Reference

For detailed information (e.g. visualization and processing of analog values), refer to Chapter 4 of the *Module Data Manual*.

8.7.3 Parameterization

Introduction

You configure the integrated I/O of CPU 31xC with STEP 7. Always make these settings when the CPU is in STOP mode. The generated parameters are downloaded from the PG to the S7-300 and written to CPU memory .

You can also choose to change the parameters with SFC 55 in the user program (see the Reference Manual *System and Standard Functions*). Refer to the structure of record 1 for the respective parameters.

Parameters of standard DI

The table below gives you an overview of the parameters for standard digital inputs.

Table 8- 8 Parameters of standard DI

Parameters	Range of values	Default	Scope
Input delay (ms)	0,1/0,5/3/15	3	Channel group

The table below gives you an overview of the parameters when using digital inputs as interrupt inputs.

Table 8- 9 Parameters of the interrupt inputs

Parameters	Range of values	Default	Scope
Interrupt input	Disabled/rising edge	Disabled	Digital input
Interrupt input	Disabled/falling edge	Disabled	Digital input

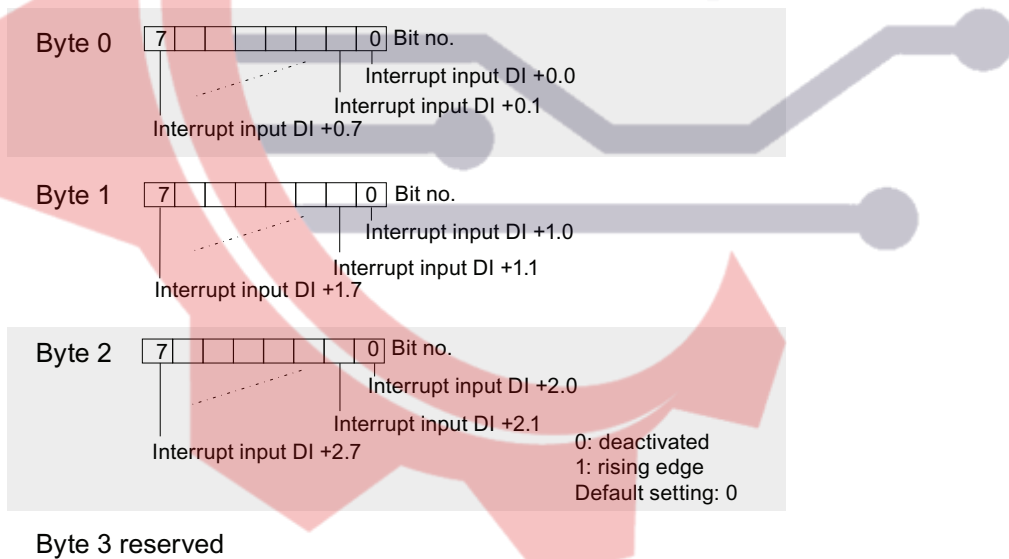

ماکان کنترول

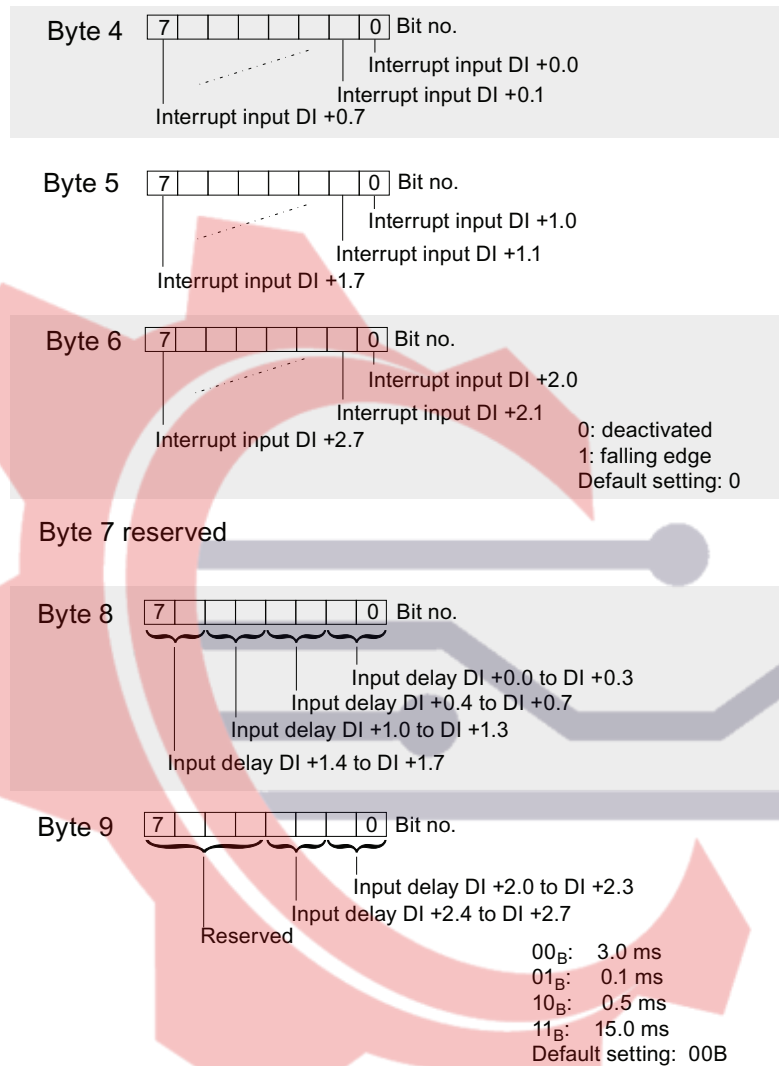

Figure 8-7 Structure of the data record 1 for standard DI and interrupt inputs (length of 10 bytes)

Parameters of standard DO

There are no parameters for standard digital outputs.

ماکان کنترول

Parameters of standard AI

The table below gives you an overview of the parameters for standard analog inputs.

Table 8- 10 Parameters of standard AI

Parameters	Range of values	Default	Scope
Integration time (ms)	2,5/16,6/20	20	Channel
Interference frequency suppression (Hz) (channels 0 to 3)	400*/60/50	50	Channel
Measuring range (channels 0 to 3)	<ul style="list-style-type: none"> • Disabled • ± 20 mA • 0 ... 20 mA • 4 ... 20 mA • ± 10 V • 0 ... 10 V 	± 10 V	Channel
Measuring method (channels 0 to 3)	Deactivated/ U voltage/ I current	U voltage	Channel
Unit of measurement (channel 4)	Celsius/Fahrenheit/ Kelvin	Celsius	Channel
Measuring range (Pt 100 input; channel 4)	Deactivated/ Pt 100/600 Ω	600 Ω	Channel
Measuring method (Pt 100 input; channel 4)	Deactivated/ resistance/ thermal resistance	Resistance	Channel
* Software filter for the interference frequency suppression is deactivated when parameters are set to "400 Hz".			

Reference

See also Chapter 4.3 in the *Module Data Reference Manual*.

ماكان كنترول

Parameters of standard AO

The table below gives you an overview of standard analog output parameters (see also Chapter 4.3 in the *Module Data Reference Manual*).

Table 8- 11 Parameters of standard AO

Parameters	Range of values	Default	Scope
Output range (channels 0 to 1)	<ul style="list-style-type: none"> Disabled ± 20 mA 0 ... 20 mA 4 ... 20 mA ± 10 V 0 ... 10 V 	± 10 V	Channel
Output type (channels 0 to 1)	Deactivated/ U voltage/ I current	U voltage	Channel

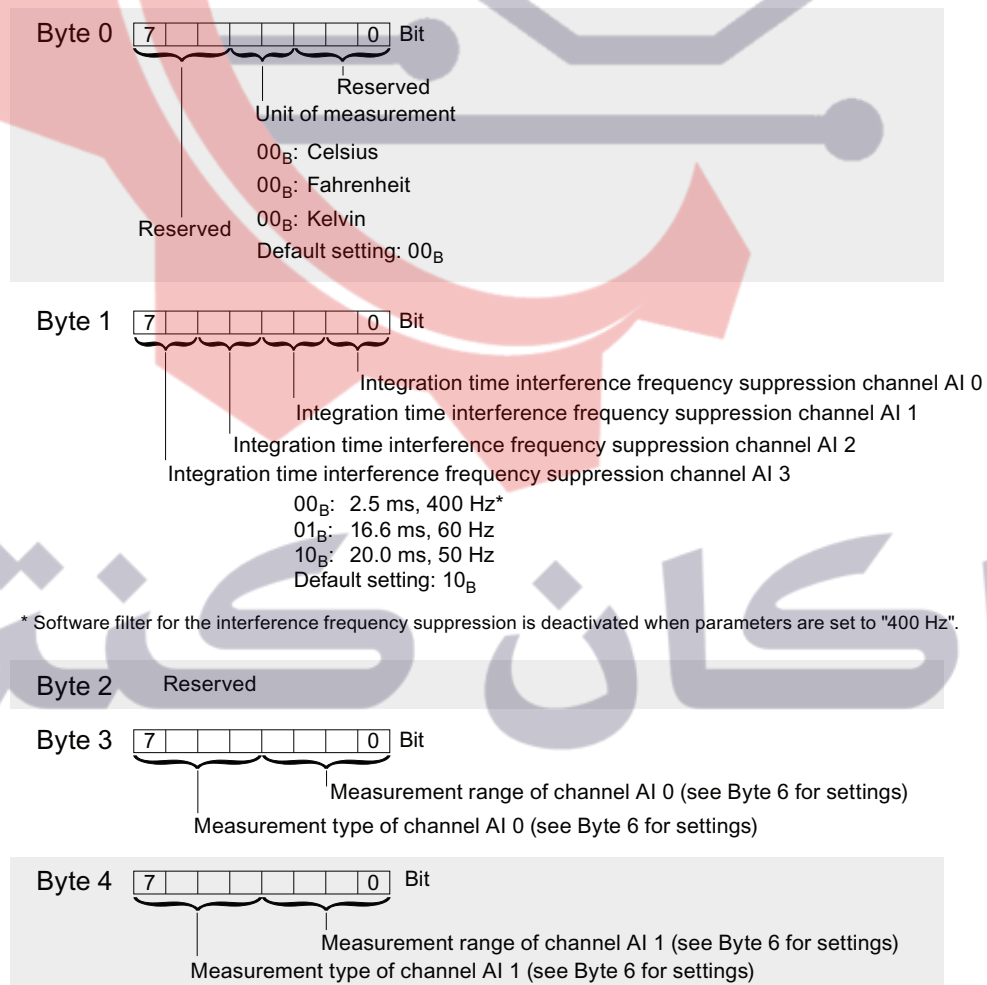

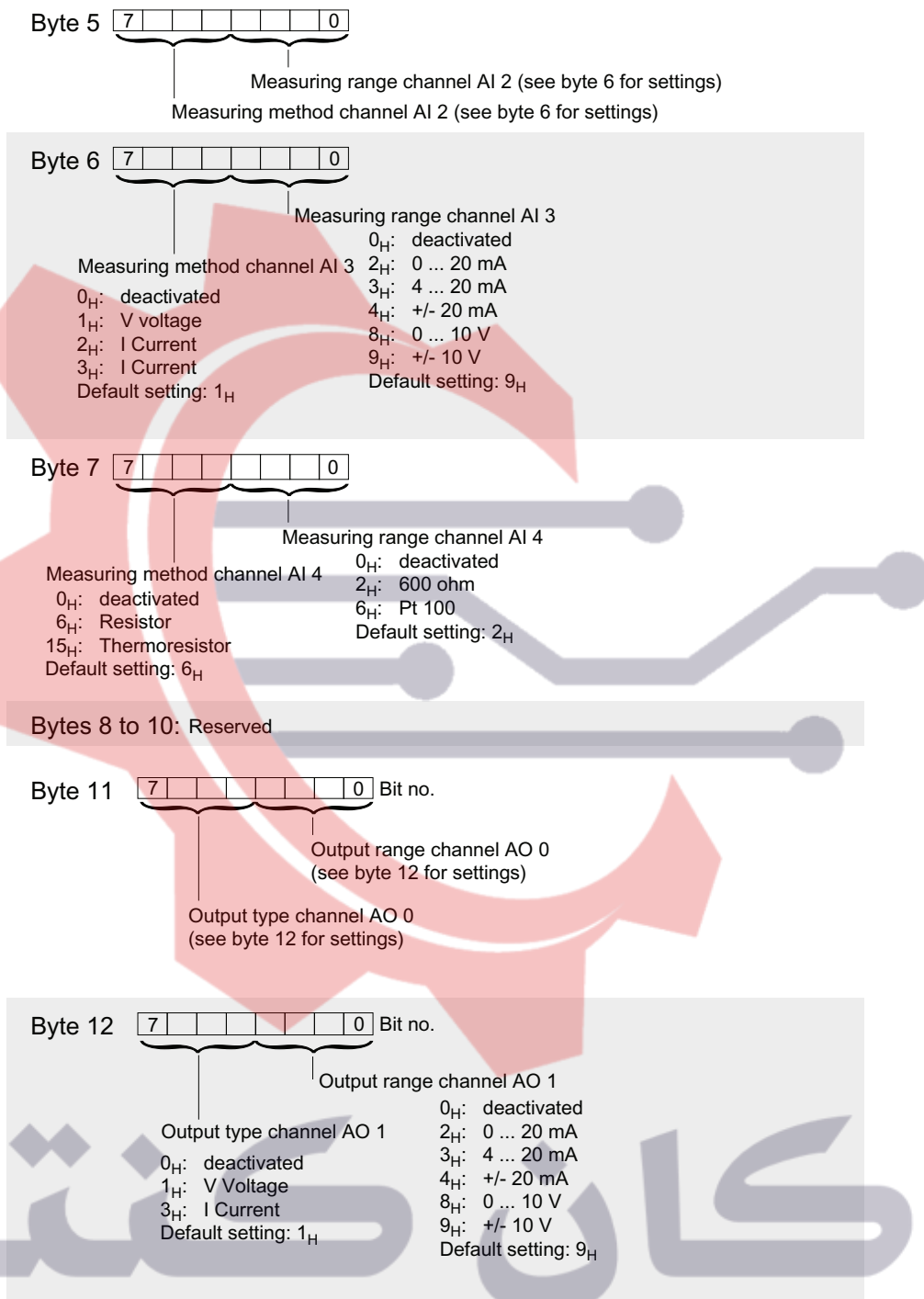

Figure 8-8 Structure of the data record 1 for standard AI/AO (length of 13 bytes)

Parameters for technological functions

The parameters for the respective function are found in the Manual *Technological Functions*.

8.7.4 Interrupts

Interrupt inputs

All digital inputs of the on-board I/O of the CPUs 31xC can be used as interrupt inputs.

You can specify the interrupt behavior for each individual input in your parameterization. Options are:

- No interrupt
- Interrupt when edge is rising
- Interrupt when edge is falling
- Interrupt when edge is rising or falling

Note

Every channel will retain 1 event if the rate of incoming interrupts exceeds the handling capacity of OB40. Further events (interrupts) will be lost, without diagnostics or explicit message.

Start information for OB40

The table below shows the relevant temporary variables (TEMP) of OB40 for the interrupt inputs of 31xC CPUs. A description of the hardware interrupt OB 40 is found in the Reference Manual *System and Standard Functions*.

Table 8- 12 Start information for OB40, relating to the interrupt inputs of the integrated I/O

Byte	Variable	Data type		Description
6/7	OB40_MDL_ADDR	WORD	B#16#7C For the CPU 314C-2 PN/DP: :B#16#88	Address of the interrupt-triggering module (in this case: default addresses of the digital inputs)
8 or higher	OB40_POINT_ADDR	DWORD	See figure below	Displaying the interrupt-triggering integrated inputs

The following figure shows an example of the states for the interrupt-triggering integrated alarm inputs for the default addresses I124.0 to I126.7.

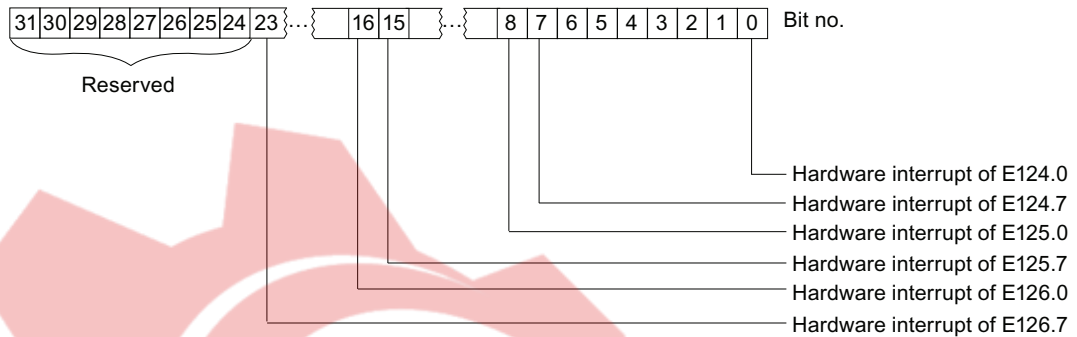

Figure 8-9 Example of the display of states of CPU 31xC interrupt inputs

8.7.5 Diagnostics

Standard I/O

Diagnostic is not available for integrated inputs/outputs used as standard I/O (see also the Reference Manual *Module Data*).

Technological functions

Diagnostics options for the respective technological function are found in the Manual *Technological Functions*.

8.7.6 Digital inputs

Introduction

This section specifies the technical specifications of the digital inputs for the CPUs 31xC.

The table includes the following CPUs:

- under CPU 313C-2, the CPUs 313C-2 DP and 313C-2 PtP
- Under CPU 314C-2, the CPU 314C-2 DP, CPU 314C-2 PtP and CPU 314C-2 PN/DP

Technical specifications

Table 8- 13 Technical specifications of digital inputs

Technical specifications				
	CPU 312C	CPU 313C	CPU 313C-2	CPU 314C-2
Module-specific data				
Module-specific data				
Number of inputs	10	24	16	24
• Inputs which can be used for technological functions	8	12	12	16
Cable length				
• unshielded, max.	600 m; for technological functions: No			
• shielded, max.	1000 m; for technological function at max. counting frequency			
	100 m	100 m	100 m	50 m
Voltage, currents, potentials				
Voltage, currents, potentials				
Rated load voltage L+	24 V DC			
• Reverse polarity protection	Yes			
Number of simultaneously controlled inputs				
• Horizontal arrangement				
– Up to 40 °C	10	24	16	24
– Up to 60 °C	5	12	8	12
• Vertical arrangement				
– Up to 40 °C	5	12	8	12
Isolation				
• Between channels and the backplane bus	Yes			
• Between channels	No			
Permissible potential difference				
• Between different circuits	75 V DC/60 V AC			
Isolation test voltage	600 V DC			
Current consumption				
• from load voltage L+ (no load), max.	–	80 mA	80 mA	80 mA
Status, interrupts, diagnostics				
Status, interrupts, diagnostics				
Status indication	Green LED per channel			
Interrupts	<ul style="list-style-type: none"> • Yes, if the corresponding channel is configured as interrupt input • For using technological functions, please refer to the <i>Technological Functions Manual</i>. 			
Diagnostic functions	<ul style="list-style-type: none"> • No diagnostics when operated as standard I/O • For using technological functions, please refer to the <i>Technological Functions Manual</i>. 			

8.7 Technical specifications of the onboard I/O

Technical specifications				
	CPU 312C	CPU 313C	CPU 313C-2	CPU 314C-2
Data for the selection of an encoder for standard DI	CPU 312C	CPU 313C	CPU 313C-2	CPU 314C-2
Input voltage				
• Rated value	24 V DC			
• For "1" signal	15 V to 30 V			
• For "0" signal	-3 V to 5 V			
Input current				
• with "1" signal, typ.	8 mA			
Input delay of standard inputs				
• Programmable	Yes (0.1 / 0.5 / 3 / 15 ms) You can reconfigure the input delay of the standard inputs during program runtime. Please note that your newly set filter time may only take effect after the previously set filter time has expired.			
• Rated value	3 ms			
For using technological functions: "Minimum pulse width/minimum pause between pulses at maximum counting frequency"	48 µs	16 µs	16 µs	8 µs
Input characteristics	to IEC 61131, Type 1			
Connection of 2-wire BEROs	Supported			
• Permitted quiescent current, max.	1.5 mA			

8.7.7 Digital outputs

Introduction

This chapter contains the technical specifications of the digital outputs for the CPUs 31xC.

The table includes the following CPUs:

- under CPU 313C-2, the CPUs 313C-2 DP and 313C-2 PtP
- Under CPU 314C-2, the CPU 314C-2 DP, CPU 314C-2 PtP and CPU 314C-2PN/DP

Fast digital outputs

Technological functions use fast digital outputs.

Technical specifications

Table 8- 14 Technical specifications of digital outputs

Technical specifications				
	CPU 312C	CPU 313C	CPU 313C-2	CPU 314C-2
Module-specific data				
	CPU 312C	CPU 313C	CPU 313C-2	CPU 314C-2
Number of outputs	6	16	16	16
• Of those as fast outputs	2	4	4	4
Notice: You cannot connect the fast outputs of your CPU in parallel.				
Cable length				
• unshielded, max.	600 m			
• shielded, max.	1000 m			
Voltage, currents, potentials				
	CPU 312C	CPU 313C	CPU 313C-2	CPU 314C-2
Rated load voltage L+	24 V DC			
• Reverse polarity protection	No			
Aggregate current of outputs (per group)				
• Horizontal installation, max.				
– Up to 40 °C	2.0 A	3.0 A	3.0 A	3.0 A
– Up to 60 °C	1.5 A	2.0 A	2.0 A	2.0 A
• Vertical installation, max.				
– Up to 40 °C	1.5 A	2.0 A	2.0 A	2.0 A
Isolation				
• Between channels and the backplane bus	Yes			
• Between channels	No	Yes	Yes	Yes
– In groups of	–	8	8	8
Permissible potential difference				
• Between different circuits	75 V DC/60 V AC			
Isolation test voltage	600 V DC			
Current consumption				
• From load voltage L+, max.	25 mA	50 mA	50 mA	50 mA
Status, interrupts, diagnostics				
	CPU 312C	CPU 313C	CPU 313C-2	CPU 314C-2
Status indication	Green LED per channel			
Interrupts	<ul style="list-style-type: none"> No interrupts when operated as standard I/O For using technological functions, please refer to the <i>Technological Functions</i> Manual. 			
Diagnostic functions	<ul style="list-style-type: none"> No diagnostics when operated as standard I/O For using technological functions, please refer to the <i>Technological Functions</i> Manual. 			

Technical specifications				
	CPU 312C	CPU 313C	CPU 313C-2	CPU 314C-2
Data for the selection of an actuator for standard DO	CPU 312C	CPU 313C	CPU 313C-2	CPU 314C-2
Output voltage				
• with "1" signal, min.	L+ (-0.8 V)			
Output current				
• With "1" signal	0.5 A			
- Rated value	5 mA to 0.6 A			
- Permissible range				
• With "0" signal (residual current), max.	0.5 mA			
Load resistance range	48 Ω to 4 kΩ			
Lamp load, max.	5 W			
Triggering a digital input	Yes			
Wiring 2 outputs in parallel				
• For redundant control of a load	Supported			
• For performance increase	Not supported			
Triggering a digital input	Supported			
Switching frequency				
• With resistance load, max.	100 Hz			
• With inductive load to IEC 947-5, DC13	0.5 Hz			
• With lamp load, max.	100 Hz			
• High-speed outputs with resistive load, max.	2.5 kHz			
Limiting (internal) of inductive shutdown voltage, typically	(L+) -48 V			
Short-circuit protection of the output	Yes, electronic clamping			
• Response threshold, typ.	1 A			

8.7.8 Analog inputs

Introduction

This chapter contains the technical specifications of analog inputs for the CPUs 31xC.

The table includes the following CPUs:

- CPU 313C
- CPU 314C-2 DP
- CPU 314C-2 PtP
- CPU 314C-2 PN/DP

Technical specifications

Table 8- 15 Technical specifications of analog inputs

Technical specifications	
Module-specific data	
Number of inputs	4 channels current/voltage input 1 channel resistance input
Cable length	
• Shielded, max.	100 m
Voltage, currents, potentials	
Resistance input	
• Open-circuit voltage, typically	3.3 V
• Measuring current, typically	1.25 mA
Isolation	
• Between channels and the backplane bus	Yes
• Between channels	No
Permissible potential difference	
• Between inputs (AI _C) and M _{ANA} (U _{CM})	8.0 VDC
• Between M _{ANA} and M _{internal} (V _{ISO})	75 V DC/60 V AC
Isolation test voltage	600 VDC
Analog value generation	
Measuring principle	Actual value encoding (successive approximation)
Integration/conversion time/resolution (per channel)	
• Programmable	Yes
• Integration time in ms	16,6/20
• Permissible input frequency, max.	400 Hz
• Resolution (including overrange)	11 bits + sign
• Noise suppression for interference frequency f ₁	60/50 Hz
Time constant of the input filter	0.38 ms
Basic execution time	1 ms
Noise suppression, error limits	
Noise suppression for $f = nx (f_1 \pm 1\%)$, ($f_1 =$ interference frequency), $n = 1, 2$	
• Common-mode interference (U _{CM} < 1.0 V)	> 40 dB
• Series-mode interference (peak value of disturbance < rated value of input range)	> 30 dB
Crosstalk between inputs	> 60 dB
Operational limit (across temperature range, relative to input range)	

Technical specifications	
• Voltage/current	<1 %
• Resistance	<1 %
Basic error limit (operational limit at 25 °C, relative to input range)	
• Voltage/current – Linearity error during measurement of current and voltage (related to input range)	<0.8% ±0.06%
• Resistance – Linearity error during resistance measurement (related to input range)	<0.8% ±0.2%
Temperature error (relative to input range)	± 0.006 %/K
Repeat accuracy (in transient state at 25 °C, relative to input range)	±0.06%
Status, interrupts, diagnostics	
Interrupts	• No interrupts when operated as standard I/O
Diagnostic functions	• No diagnostics when operated as standard I/O • For using technological functions, please refer to the <i>Technological Functions</i> Manual.
Encoder selection data	
Input ranges (rated values)/input impedance	
• Voltage	± 10 V/100 kΩ 0 V to 10 V/100 kΩ
• Current	± 20 mA/100 Ω 0 mA to 20 mA/100 Ω 4 mA to 20 mA/100 Ω
• Resistance	0 Ω to 600 Ω/10 MΩ
• Resistance thermometer	Pt 100/10 MΩ
Permitted input voltage (destruction limit)	
• At voltage input, max.	30 V sustained
• For current input, max.	5 V sustained
Permitted input current (destruction limit)	
• At voltage input, max.	0.5 mA sustained
• For current input, max.	50 mA sustained
Connection of signal transmitters	
• For voltage measurement	Supported
• For current measurement – As 2-wire transducer – As 4-wire transducer	supported with external supply supported

Technical specifications	
<ul style="list-style-type: none"> For resistance measurement - With 2-wire connection - With 3-wire connection - With 4-wire connection 	Possible, without compensation of the line resistances Not possible Not possible
Linearization of the characteristics curves	By software
<ul style="list-style-type: none"> For resistance thermometers 	Pt 100
Temperature compensation	No
Technical unit of temperature measurement	Degrees Celsius (°C))Degrees Fahrenheit (°F) Kelvin (K)

8.7.9 Analog outputs

Introduction

This chapter contains the technical specifications of the analog outputs for the CPUs 31xC. The table includes the following CPUs:

- CPU 313C
- CPU 314C-2 DP
- CPU 314C-2 PtP
- CPU 314C-2 PN/DP

Technical specifications

Table 8- 16 Technical specifications of analog outputs

Technical specifications	
Module-specific data	
Number of outputs	2
Cable length	
<ul style="list-style-type: none"> Shielded, max. 	200 m
Potentials	
Isolation	
<ul style="list-style-type: none"> Between channels and the backplane bus 	Yes
<ul style="list-style-type: none"> Between channels 	No
Permissible potential difference	
<ul style="list-style-type: none"> Between M_{ANA} and M_{internal} (V_{ISO}) 	75 V DC/60 V AC
Isolation test voltage	600 V DC

Technical specifications	
Analog value generation	
Resolution (including overrange)	11 bits + sign
Conversion time (per channel)	1 ms
Settling time	
• With resistive load	0.6 ms
• With capacitive load	1.0 ms
• With inductive load	0.5 ms
Noise suppression, error limits	
Crosstalk between outputs	> 60 dB
Operational limit (across temperature range, relative to output range)	
• Voltage/current	±1 %
Basic error limit (operational limit at 25 °C, relative to output range)	
• Voltage/current	±0.8%
Temperature error (relative to output range)	± 0.01%/K
Linearity error (relative to output range)	±0.15%
Repeat accuracy (in transient state at 25 °C, relative to output range)	±0.06%
Output ripple; range 0 Hz to 50 kHz (relative to output range)	± 0.1%
Status, interrupts, diagnostics	
Interrupts	<ul style="list-style-type: none"> • No interrupts when operated as standard I/O • For using technological functions, please refer to the <i>Technological Functions</i> Manual.
Diagnostic functions	<ul style="list-style-type: none"> • No diagnostics when operated as standard I/O • For using technological functions, please refer to the <i>Technological Functions</i> Manual.
Actuator selection data	
Output range (rated values)	
• Voltage	± 10 V 0 V to 10 V
• Current	± 20 mA 0 mA to 20 mA 4 mA to 20 mA
Load impedance (in the nominal range of the output)	
• At voltage outputs, min. – Capacitive load, max.	1 kΩ 0.1 μF
• At current outputs, max. – Inductive load	300 Ω 0.1 mH
Voltage output	
• Short-circuit protection	Yes

Technical specifications	
• Short-circuit current, typically:	55 mA
Current output	
• Open-circuit voltage, typically	14 V
Destruction limit against external voltages/currents	
• Voltage at the outputs against M _{ANA} , max.	16 V sustained
• Current, max.	50 mA sustained
Wiring the actuators	
• For voltage output - 2-wire connection - 4-wire connection (measuring line)	Supported, without compensation of the line resistances Not supported
• For current output - 2-wire connection	Supported

ماكان كنترول



ماكان كنترول

Technical specifications of CPU 31x

9.1 General technical specifications

9.1.1 Dimensions of CPU 31x

Each CPU features the same height and depth, only the width differs.

- Height: 125 mm
- Depth: 115 mm, or 180 mm with opened front cover.

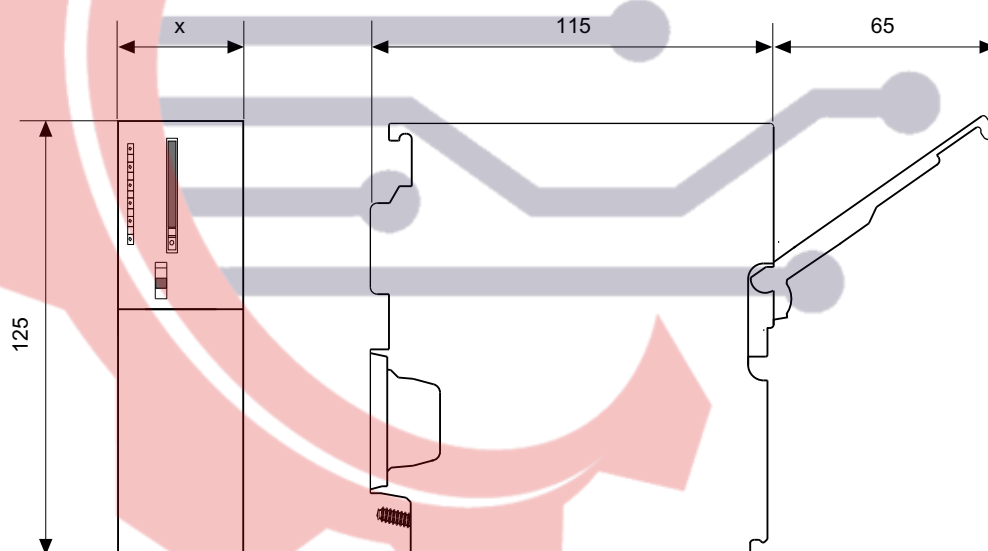

Figure 9-1 Dimensions of CPU 31x

Width of CPU

CPU	Width (x)
CPU 312	40 mm
CPU 314	40 mm
CPU 315-2 DP	40 mm
CPU 315-2 PN/DP	40 mm
CPU 317-2 DP	40 mm
CPU 317-2 PN/DP	40 mm
CPU 319	120 mm

9.1.2 Technical specifications of the SIMATIC Micro Memory Card

Compatible SIMATIC Micro Memory Cards

The following memory modules are available:

Table 9- 1 Available SIMATIC Micro Memory Cards

Type		Order number	Required for a firmware update via SIMATIC Micro Memory Card
Micro Memory Card	64 KB	6ES7953-8LFxx-0AA0	–
Micro Memory Card	128 KB	6ES7953-8LGxx-0AA0	–
Micro Memory Card	512 KB	6ES7953-8LJxx-0AA0	–
Micro Memory Card	2 MB	6ES7953-8LLxx-0AA0	Minimum requirement for CPUs without DP interface
Micro Memory Card	4 MB	6ES7953-8LMxx-0AA0	Minimum requirements for CPUs with DP interface, but without PN interface
Micro Memory Card	8 MB	6ES7953-8LPxx-0AA0	Minimum requirements for CPUs with DP and PN interface

Maximum number of loadable blocks on the SIMATIC Micro Memory Card

The number of blocks that can be stored on the SIMATIC Micro Memory Card depends on the capacity of the SIMATIC Micro Memory Card being used. The maximum number of blocks that can be loaded is therefore limited by the capacity of your SIMATIC Micro Memory Card (including blocks generated with the "CREATE DB" SFC)

Table 9- 2 Maximum number of loadable blocks on the SIMATIC Micro Memory Card

Size of SIMATIC Micro Memory Card	... Maximum number of blocks that can be loaded
64 KB	768
128 KB	1024
512 KB	2560
2 MB	The maximum number of blocks that can be loaded on a specific CPU is less than the number of blocks that can be stored on the SIMATIC Micro Memory Card. For information about the maximum number of blocks that can be loaded on a specific CPU, refer to the corresponding technical specification.
4 MB	
8 MB	

9.2 CPU 312

Technical specifications

Table 9- 3 Technical specifications of the CPU 312

Technical specifications	
CPU and version	
• MLFB	6ES7312-1AE14-0AB0
• Hardware version	01
• Firmware version	V3.3
• Associated programming package	STEP 7 as of V5.5 + SP1 or STEP 7 as of V5.2 + SP1 with HSP 218
Memory	
Main memory	
• Integrated	32 KB
• Expandable	No
• Maximum size of non-volatile memory for retentive data blocks,	32 KB
Load memory	
• Pluggable (MMC)	Yes
• Pluggable (MMC), max.	8 MB
• Data retention on the Micro Memory Card (after the last programming action), min.	10 years
Backup	
• Available	Yes (ensured with Micro Memory Card - maintenance-free)
• Without battery	Yes (program and data)
Execution times	
• for bit operation, min.	0.1 μ s
• for word operations, min.	0.24 μ s
• for fixed-point arithmetic, min.	0.32 μ s
• for floating-point arithmetic, min.	1.10 μ s
Timers/counters and their retentivity	
S7 counters	
• Number	256
Retentivity	
• Configurable	Yes
• Default	Z 0 to Z 7

Technical specifications	
Counting range	
• Low limit	0
• High limit	999
IEC counter	
• Available	Yes
• Type	SFB
• Number	Unlimited (limited only by main memory size)
S7 timers	
• Number	256
Retentivity	
• Configurable	Yes
• Default	No retentivity
Time setting range	
• Low limit	10 ms
• High limit	9990 s
IEC timer	
• Available	Yes
• Type	SFB
• Number	Unlimited (limited only by main memory size)
Data areas and their retentivity	
Bit memory	
• Number, max.	256 bytes
• Retentivity, available	Yes (MB 0 to MB 255)
• Retentivity, default	MB 0 to MB 15
• Number of clock memories	8 (1 memory byte)
Data blocks	
• Number, max.	1024 (in the number range 1 to 16000)
• Size, max.	32 KB
• Retentivity, configurable	Yes, via non-retain feature on the DB
• Retentivity, default	Yes
Local data	
• Per priority class, max.	32 KB per execution level, 2 KB per block

Technical specifications	
Blocks	
• Number of blocks (total)	1024 (DBs, FCs, FBs) The maximum number of blocks that can be loaded may be reduced due to the Micro Memory Card you are using.
OB	See instruction list
• Size, max.	32 KB
• Number of free cycle OBs	1 (OB 1)
• Number of time-of-day interrupt OBs	1 (OB 10)
• Number of time-delay interrupt OBs	2 (OB 20, 21)
• Number of cyclic interrupt OBs	4 (OB 32, 33, 34, 35)
• Number of hardware interrupt OBs	1 (OB 40)
• Number of restart OBs	1 (OB 100)
• Number of asynchronous error OBs	4 (OB 80, 82, 85, 87)
• Number of synchronous error OBs	2 (OB 121, 122)
Nesting depth	
• Per priority class	16
• Additionally within an error OB	4
FB	See instruction list
• Number, max.	1024 (in the number range 0 to 7999)
• Size	32 KB
FC	See instruction list
• Number, max.	1024 (in the number range 0 to 7999)
• Size	32 KB
Address ranges (inputs/outputs)	
I/O address area	
• Inputs	1024 bytes (freely addressable)
• Outputs	1024 bytes (freely addressable)
I/O process image	
• Inputs	1024 bytes
• Outputs	1024 bytes
• Inputs, adjustable	1024 bytes
• Outputs, adjustable	1024 bytes
• Inputs, preset	128 bytes
• Outputs, preset	128 bytes

Technical specifications	
Digital channels	
• Inputs	256
• Outputs	256
• Inputs, of those central	256
• Outputs, of those central	256
Analog channels	
• Inputs	64
• Outputs	64
• Inputs, of those central	64
• Outputs, of those central	64
Hardware configuration	
• Racks, max.	1
• Modules per rack, max.	8
Number of DP masters	
• Integrated	0
• Via CP	4
Number of usable FMs and CPs (recommended)	
• FM, max.	8
• CP, point-to-point	8
• CP, LAN	4
Time-of-day	
Clock	
• Software clock	Yes
• Buffered, can be synchronized	Buffered: No Can be synchronized: Yes
• Factory setting	DT#1994-01-01-00:00:00
• Behavior of the real-time clock after POWER ON	The clock continues at the time of day it had when power was switched off.
• Daily deviation	10 s, typ. 2 s
Runtime meter	
• Number	1
• Number/number range	0
• Range of values	0 to 2 ³¹ hours (if SFC 101 is used)
• Granularity	1 hour
• Retentive	Yes; must be manually restarted after every restart

Technical specifications	
Clock synchronization	
• supported	Yes
• On MPI, master	Yes
• On MPI, slave	Yes
• On the AS, master	Yes
• In AS, Slave	No
S7 signaling functions	
• Number of stations that can be logged on for signaling functions, max.	6 (depends on the number of connections configured for PG/OP and S7 basic communication)
• Process error diagnostic messages	Yes
• Simultaneously enabled interrupt S blocks, max.	300
Test and startup functions	
Status/modify variable	Yes
• Variables	Inputs, outputs, bit memories, DBs, timers, counters
• Maximum number of variables	30
• Status variables, max.	30
• Modify variables, max.	14
Forcing	
• Forcing	Yes
• Variables	Inputs, outputs
• Maximum number of tags	10
Status block	Yes (max. 2 blocks simultaneously)
Single step	
• Number of breakpoints	4
Diagnostic buffer	
• Available	Yes
• Maximum number of entries	500
• Configurable	No
• of which are power-failure-proof	100, only the last 100 entries are retentive
• Maximum number of entries that can be read in RUN	499
• Number of entries that can be set in RUN	Yes (from 10 to 499)
• Number of preset entries in RUN	10

Technical specifications	
Service data	
• Can be read out	Yes
Monitoring function	
• Status LEDs	Yes
Communication functions	
PG/OP communication	
	Yes
Prioritized OCM communication	
• Supported	No
Routing	
• Number of routing connections	-
• Data record routing	No
Global data communication	
• Supported	Yes
• Number of GD circles, max.	8
• Number of GD packages, max.	8
• Number of GD packages, sender, max.	8
• Number of GD packages, receiver, max.	8
• Size of GD packages, max.	22 bytes
• Size of GD packages, of those consistent, max.	22 bytes
S7 basic communication	
• Supported	Yes
• User data per job, max.	76 bytes
• User data per job, consistent, max.	76 bytes (for X_SEND/RCV); 64 bytes (for X_PUT/GET as server)
S7 communication	
• Supported	Yes
• As server	Yes
• As client	Yes, via CP and loadable FBs
• User data per job, max.	180 bytes (for PUT/GET)
• User data per job, consistent, max.	240 bytes (as server)
S5-compatible communication	
• Supported	Yes (via CP and loadable FCs)
Maximum number of connections	
• Total	6

Technical specifications	
Suitable for PG communication	5
• PG communication, reserved	1
• PG communication, configurable, min.	1
• PG communication, configurable, max.	5
Suitable for OP communication	5
• OP communication, reserved	1
• OP communication, configurable, min.	1
• OP communication, configurable, max.	5
Suitable for S7 basic communication	2
• S7 basic communication, reserved	0
• S7 basic communication, configurable, min.	0
• S7 basic communication, configurable, max.	2
Interfaces	
1st interface	
Interface designation	X1
Type of interface	Integrated RS 485 interface
Hardware	RS 485
• electrically disconnected	No
• Interface power supply (15 V DC to 30 V DC), max.	200 mA
Functionality	
• MPI	Yes
• DP master	No
• DP slave	No
• Point-to-point connection	No
MPI	
Services	
• PG/OP communication	Yes
• Routing	No
• Global data communication	Yes
• S7 basic communication	Yes
• S7 communication	Yes (only server; connection configured at one end)
• S7 communication, as client	No
• S7 communication, as server	Yes
• Transmission rate, max.	187,5 kbps

Technical specifications	
Programming	
Programming language	
• LAD	Yes
• FBD	Yes
• STL	Yes
• SCL	Yes
• GRAPH	Yes
• HiGraph®	Yes
Instruction set	
• Nesting levels	8
Know-how protection	
• User program/password security	Yes
• Block encryption	Yes, using S7-Block Privacy
System functions (SFC)	
See instruction list	
System function blocks (SFB)	
See instruction list	
Dimensions	
• Mounting dimensions W x H x D (mm)	40 x 125 x 130
• Weight	270 g
Voltages and currents	
• Power supply (rated value)	24 V DC
• Low limit of admissible range (DC)	19.2 V
• High limit of admissible range (DC)	28.8 V
• Current consumption (open-circuit), typically	140 mA
• Inrush current, typ.	3.5 A
• Current consumption (rated value)	650 mA
• I ² t	1 A ² s
• External protection of power supply lines (recommended), min.	2 A
• Power loss, typically	4 W

9.3 CPU 314

Technical specifications of the CPU 314

Table 9- 4 Technical specifications of the CPU 314

Technical specifications	
CPU and version	
• MLFB	6ES7314-1AG14-0AB0
• Hardware version	01
• Firmware version	V3.3
• Associated programming package	STEP 7 as of V5.5 + SP1 or STEP 7 as of V5.2 + SP1 with HSP 218
Memory	
Main memory	
• Integrated	128 KB
• Expandable	No
• Maximum size of non-volatile memory for retentive data blocks	64 KB
Load memory	
• Pluggable (MMC)	Yes
• Pluggable (MMC), max.	8 MB
• Data retention on the Micro Memory Card (after the last programming action), min.	10 years
Backup	
• Available	Yes (ensured with Micro Memory Card - maintenance-free)
• Without battery	Yes (program and data)
Execution times	
• For bit operation, min.	0.06 μ s
• For word operations, min.	0.12 μ s
• For fixed-point arithmetic, min.	0.16 μ s
• Minimum for floating-point arithmetic	0.59 μ s
Timers/counters and their retentivity	
S7 counters	
• Number	256
Retentivity	
• Configurable	Yes
• Default	Z 0 to Z 7

Technical specifications	
Counting range	
• Low limit	0
• High limit	999
IEC counter	
• Available	Yes
• Type	SFB
• Number	Unlimited (limited only by main memory size)
S7 timers	
• Number	256
Retentivity	
• Configurable	Yes
• Default	No retentivity
Time setting range	
• Low limit	10 ms
• High limit	9990 s
IEC timer	
• Available	Yes
• Type	SFB
• Number	Unlimited (limited only by main memory size)
Data areas and their retentivity	
Bit memory	
• Number, max.	256 bytes
• Retentivity, available	Yes (MB 0 to MB 255)
• Retentivity, default	MB 0 to MB 15
• Number of clock memories	8 (1 memory byte)
Data blocks	
• Number, max.	1024 (in the number range 1 to 16000)
• Size, max.	64 KB
• Retentivity, configurable	Yes, via non-retain feature on the DB
• Retentivity, default	Yes
Local data	
• Per priority class, max.	32 KB per execution level, 2 KB per block

Technical specifications	
Blocks	
• Number of blocks (total)	1024 (DBs, FCs, FBs) The maximum number of blocks that can be loaded may be reduced due to the Micro Memory Card you are using.
OB	See instruction list
• Size, max.	64 KB
• Number of free cycle OBs	1 (OB 1)
• Number of time-of-day interrupt OBs	1 (OB 10)
• Number of time-delay interrupt OBs	2 (OB 20, 21)
• Number of cyclic interrupt OBs	4 (OB 32, 33, 34, 35)
• Number of hardware interrupt OBs	1 (OB 40)
• Number of restart OBs	1 (OB 100)
• Number of asynchronous error OBs	4 (OB 80, 82, 85,87)
• Number of synchronous error OBs	2 (OB 121, 122)
Nesting depth	
• Per priority class	16
• Additionally within an error OB	4
FB	See instruction list
• Number, max.	1024 (in the number range 0 to 7999)
• Size, max.	64 KB
FC	See instruction list
• Number, max.	1024 (in the number range 0 to 7999)
• Size, max.	64 KB
Address ranges (inputs/outputs)	
I/O address area	
• Inputs	1024 bytes
• Outputs	1024 bytes
I/O process image	
• Inputs	1024 bytes
• Outputs	1024 bytes
• Inputs, adjustable	1024 bytes
• Outputs, adjustable	1024 bytes
• Inputs, preset	128 bytes
• Outputs, preset	128 bytes

Technical specifications	
Digital channels	
• Inputs	1024
• Outputs	1024
• Inputs, of those central	1024
• Outputs, of those central	1024
Analog channels	
• Inputs	256
• Outputs	256
• Inputs, of those central	256
• Outputs, of those central	256
Hardware configuration	
• Racks, max.	4
• Modules per rack, max.	8
Number of DP masters	
• Integrated	0
• Via CP	4
Number of usable FMs and CPs (recommended)	
• FM, max.	8
• CP, point-to-point	8
• CP, LAN	10
Time-of-day	
Clock	
• Hardware clock (real-time)	Yes
• Buffered, can be synchronized	Yes
• Factory setting	DT#1994-01-01-00:00:00
• Buffered period	Typically 6 weeks (at an ambient temperature of 40 °C)
• Behavior of the real-time clock after POWER ON	The clock continues running after POWER OFF
• Behavior after expiration of the buffered period	The clock continues at the time of day it had when power was switched off.
• Deviation per day, max.	10 s, typ. 2 s
Runtime meter	
• Number	1
• Number/number range	0

Technical specifications	
• Range of values	0 to 2 ³¹ hours (using the SFC 101)
• Granularity	1 hour
• Retentive	Yes; must be manually restarted after every restart
Clock synchronization	
• Supported	Yes
• On MPI, master	Yes
• On MPI, slave	Yes
• On the AS, master	Yes
• On the AS, slave	No
S7 signaling functions	
• Number of stations that can be logged on for signaling functions (e.g. OS)	12 (depends on the number of connections configured for PG/OP and S7 basic communication)
• Process error diagnostic messages	Yes
• Simultaneously enabled interrupt S blocks, max.	300
Test and startup functions	
Status/modify	
• Status/modify variable	Yes
• Variables	Inputs, outputs, bit memories, DBs, timers, counters
• Maximum number of variables	30
• Status variables, max.	30
• Modify variables, max.	14
Forcing	
• Forcing	Yes
• Variables	Inputs/outputs
• Maximum number of tags	10
• Status block	Yes (max. 2 blocks simultaneously)
Single step	
• Number of breakpoints	4
Diagnostic buffer	
• Available	Yes
• Maximum number of entries	500
• Configurable	No

Technical specifications	
• Of which are power-failure-proof	100, only the last 100 entries are retentive
• Maximum number of entries that can be read in RUN	499
• Number of entries that can be set in RUN	Yes (from 10 to 499)
• Number of preset entries in RUN	10
Service data	
• Can be read out	Yes
Monitoring function	
• Status LEDs	Yes
Communication functions	
PG/OP communication	Yes
Prioritized OCM communication	
• supported	No
Routing	
• Number of routing connections	-
• Data record routing	No
Global data communication	
• Supported	Yes
• Number of GD circles, max.	8
• Number of GD packages, max.	8
• Number of GD packages, sender, max.	8
• Number of GD packages, receiver, max.	8
• Size of GD packages, max.	22 bytes
• Size of GD packages, of those consistent, max.	22 bytes
S7 basic communication	
• Supported	Yes
• User data per job, max.	76 bytes
• User data per job, consistent, max.	76 bytes (for X_SEND/RCV); 64 bytes (for X_PUT/GET as server)
S7 communication	
• Supported	Yes
• As server	Yes
• As client	Yes (via CP and loadable FBs)
• User data per job, max.	180 bytes (with PUT / GET)
• User data per job, consistent	240 bytes

Technical specifications	
S5-compatible communication	
• Supported	Yes (via CP and loadable FCs)
Number of connections	
• Total	12
Suitable for PG communication	
• PG communication, reserved	1
• PG communication, configurable, min.	1
• PG communication, configurable, max.	11
Suitable for OP communication	
• OP communication, reserved	1
• OP communication, configurable, min.	1
• OP communication, configurable, max.	11
Suitable for S7 basic communication	
• S7 basic communication, reserved	0
• S7 basic communication, configurable, min.	0
• S7 basic communication, configurable, max.	8
Interfaces	
1st interface	
Interface designation	X1
Type of interface	Integrated RS 485 interface
Hardware	RS 485
• electrically disconnected	No
• Interface power supply (15 V DC to 30 V DC), max.	200 mA
Functionality	
• MPI	Yes
• DP master	No
• DP slave	No
• Point-to-point connection	No
MPI	
Services	
• PG/OP communication	Yes
• Routing	No
• Global data communication	Yes
• S7 basic communication	Yes
• S7 communication	Yes (server only, connections configured at one end)

Technical specifications	
• S7 communication, as client	No
• S7 communication, as server	Yes
Transmission rate, max.	187,5 kbps
Programming	
Programming language	
• LAD	Yes
• FBD	Yes
• STL	Yes
• SCL	Yes
• CFC	Yes
• GRAPH	Yes
• HiGraph®	Yes
Instruction set	See instruction list
• Nesting levels	8
Know-how protection	
• User program/password security	Yes
• Block encryption	Yes, using S7-Block Privacy
System functions (SFC)	See instruction list
System function blocks (SFB)	See instruction list
Dimensions	
• Mounting dimensions W x H x D (mm)	40 x 125 x 130
• Weight	280 g
Voltages and currents	
• Power supply (rated value)	24 V DC
• Low limit of admissible range (DC)	19.2 V
• High limit of admissible range (DC)	28.8 V
• Current consumption (open-circuit), typically	140 mA
• Inrush current, typ.	3.5 A
• Current consumption (rated value)	650 mA
• I ² t	1 A ² s
• External protection of power supply lines (recommended), min.	2 A
• Power loss, typically	4 W

9.4 CPU 315-2 DP

Technical specifications

Table 9- 5 Technical specifications of the CPU 315-2 DP

Technical specifications	
CPU and version	
• MLFB	6ES7315-2AH14-0AB0
• Hardware version	01
• Firmware version	V3.3
• Associated programming package	STEP 7 as of V5.5 + SP1 or STEP 7 as of V5.2 + SP1 with HSP 218
Memory	
Main memory	
• Integrated	256 KB
• Expandable	No
• Maximum size of non-volatile memory for retentive data blocks	128 KB
Load memory	
• Pluggable (MMC)	Yes
• Pluggable (MMC), max.	8 MB
• Data retention on the Micro Memory Card (after the last programming action), min.	10 years
Backup	
• Available	Yes (ensured with Micro Memory Card - maintenance-free)
• Without battery	Yes (program and data)
Execution times	
• For bit operation, min.	0.05 μ s
• For word operations, min.	0.09 μ s
• For fixed-point arithmetic, min.	0.12 μ s
• Minimum for floating-point arithmetic	0.45 μ s
Timers/counters and their retentivity	
S7 counters	
• Number	256
Retentivity	
• Configurable	Yes
• Default	Z 0 to Z 7

Technical specifications	
Counting range	
• Low limit	0
• High limit	999
IEC counter	
• Available	Yes
• Type	SFB
• Number	Unlimited (limited only by main memory size)
S7 timers	
• Number	256
Retentivity	
• Configurable	Yes
• Default	No retentivity
Time setting range	
• Low limit	10 ms
• High limit	9990 s
IEC timer	
• Available	Yes
• Type	SFB
• Number	Unlimited (limited only by main memory size)
Data areas and their retentivity	
Bit memory	
• Number, max.	2048 bytes
• Retentivity, available	Yes (MB 0 to MB 2047)
• Retentivity, default	MB 0 to MB 15
• Number of clock memories	8 (1 memory byte)
Data blocks	
• Number, max.	1024 (in the number range 1 to 16000)
• Size, max.	64 KB
• Retentivity, configurable	Yes, via non-retain feature on the DB
• Retentivity, default	Yes
Local data	
• Per priority class, max.	32 KB per execution level, 2 KB per block

Technical specifications	
Blocks	
• Number of blocks (total)	1024 (DBs, FCs, FBs) The maximum number of blocks that can be loaded may be reduced due to the Micro Memory Card you are using.
OB	See instruction list
• Size	64 KB
• Number of free cycle OBs	1 (OB 1)
• Number of time-of-day interrupt OBs	1 (OB 10)
• Number of time-delay interrupt OBs	2 (OB 20, 21)
• Number of cyclic interrupt OBs	4 (OB 32, 33, 34, 35)
• Number of hardware interrupt OBs	1 (OB 40)
• Number of DPV1 interrupt OBs	3 (OB 55, 56, 57)
• Number of isochronous interrupt OBs	1 (OB 61)
• Number of restart OBs	1 (OB 100)
• Number of asynchronous error OBs	5 (OB 80, 82, 85, 86, 87)
• Number of synchronous error OBs	2 (OB 121, 122)
Nesting depth	
• Per priority class	16
• Additionally within an error OB	4
FB	See instruction list
• Number, max.	1024 (in the number range 0 to 7999)
• Size, max.	64 KB
FC	See instruction list
• Number, max.	1024 (in the number range 0 to 7999)
• Size, max.	64 KB
Address ranges (inputs/outputs)	
I/O address area	
• Inputs	2048 bytes (freely addressable)
• Outputs	2048 bytes (freely addressable)
Distributed	
• Inputs	2048 bytes
• Outputs	2048 bytes
I/O process image	
• Inputs	2048 bytes

Technical specifications	
• Outputs	2048 bytes
• Inputs, adjustable	2048 bytes
• Outputs, preset	2048 bytes
• Inputs, adjustable	128 bytes
• Outputs, preset	128 bytes
Process image partitions	
• Number of partial process images, max.	1
Digital channels	
• Inputs	16384
• Outputs	16384
• Inputs, of those central	1024
• Outputs, of those central	1024
Analog channels	
• Inputs	1024
• Outputs	1024
• Inputs, of those central	256
• Outputs, of those central	256
Hardware configuration	
• Racks, max.	4
• Modules per rack, max.	8
Number of DP masters	
• Integrated	1
• Via CP	4
Number of usable FMs and CPs (recommended)	
• FM	8
• CP, point-to-point	8
• CP, LAN	10
Time-of-day	
Clock	
• Hardware clock (real-time)	Yes
• Buffered, can be synchronized	Yes
• Buffered period	Typically 6 weeks (at an ambient temperature of 40 °C)
• Behavior of the real-time clock after POWER OFF ON	The clock continues running after POWER OFF

Technical specifications	
• Behavior after expiration of the buffered period	The clock continues at the time of day it had when power was switched off.
• Deviation per day, max.	10 s, typ. 2 s
Runtime meter	
• Number	1
• Number/number range	0
• Range of values	0 to 2 ³¹ hours (if SFC 101 is used)
• Granularity	1 hour
• Retentive	Yes; must be manually restarted after every restart
Clock synchronization	
• Supported	Yes
• On MPI, master	Yes
• On MPI, slave	Yes
• On DP, master	Yes (DP slave must be time slave)
• On DP, slave	Yes
• On the AS, master	Yes
• On the AS, slave	No
S7 signaling functions	
• Number of stations that can be logged on for signaling functions (e.g. OS)	16 (depends on the number of connections configured for PG/OP and S7 basic communication)
• Process error diagnostic messages	Yes
• Simultaneously enabled interrupt S blocks, max.	300
Test and startup functions	
Status/modify	
• Status/modify variable	Yes
• Variables	Inputs, outputs, bit memories, DBs, timers, counters
• Maximum number of variables	30
• Status variables, max.	30
• Modify variables, max.	14
Forcing	
• Forcing	Yes
• Variables	Inputs, outputs

Technical specifications	
• Maximum number of tags	10
Status block	Yes (max. 2 blocks simultaneously)
Single step	Yes
• Number of breakpoints	4
Diagnostic buffer	
• Available	Yes
• Maximum number of entries	500
• Configurable	No
• Of which are power-failure-proof	100, only the last 100 entries are retentive
• Maximum number of entries that can be read in RUN	499
• Number of entries that can be set in RUN	Yes (from 10 to 499)
• Number of preset entries in RUN	10
Service data	
• Can be read out	Yes
Monitoring function	
• Status LEDs	Yes
Communication functions	
PG/OP communication	Yes
Prioritized OCM communication	
• Supported	Yes
Routing	
• Number of routing connections, max.	4
• Data record routing	Yes
Global data communication	
• Supported	Yes
• Number of GD circles, max.	8
• Number of GD packages, max.	8
• Number of GD packages, sender, max.	8
• Number of GD packages, receiver, max.	8
• Size of GD packages, max.	22 bytes
• Size of GD packages, of those consistent, max.	22 bytes
S7 basic communication	
• Supported	Yes
• User data per job, max.	76 bytes

Technical specifications	
• User data per job, consistent, max.	76 bytes (for X_SEND/RCV); 64 bytes (for X_PUT/GET as server)
S7 communication	
• Supported	Yes
• As server	Yes
• As client	Yes (via CP and loadable FBs)
• User data per job, max.	180 bytes (for PUT/GET)
• User data per job, consistent, max.	240 bytes (as server)
S5-compatible communication	
• Supported	Yes (via CP and loadable FCs)
Number of connections	
• Total	16
Suitable for PG communication	
• PG communication, reserved	1
• PG communication, configurable, min.	1
• PG communication, configurable, max.	15
Suitable for OP communication	
• OP communication, reserved	1
• OP communication, configurable, min.	1
• OP communication, configurable, max.	15
Suitable for S7 basic communication	
• S7 basic communication, reserved	0
• S7 basic communication, configurable, min.	0
• S7 basic communication, configurable, max.	12
Interfaces	
1st interface	
Interface designation	X1
Type of interface	Integrated RS 485 interface
Hardware	RS 485
• electrically disconnected	No
• Interface power supply (15 V DC to 30 V DC), max.	200 mA
Functionality	
• MPI	Yes
• DP master	No
• DP slave	No

Technical specifications	
• Point-to-point connection	No
MPI	
Services	
• PG/OP communication	Yes
• Routing	Yes
• Global data communication	Yes
• S7 basic communication	Yes
• S7 communication	Yes (server only, connections configured at one end)
• S7 communication, as client	No
• S7 communication, as server	Yes
Transmission rate	187,5 kbps
2nd interface	
Interface designation	X2
Type of interface	Integrated RS 485 interface
Hardware	RS 485
• electrically disconnected	Yes
• Interface power supply (15 V DC to 30 V DC), max.	200 mA
Functionality	
• MPI	No
• DP master	Yes
• DP slave	Yes
• Point-to-point connection	No
DP master	
Services	
• PG/OP communication	Yes
• Routing	Yes
• Global data communication	No
• S7 basic communication	Yes (intelligent blocks only)
• S7 communication	Yes (server only, connections configured at one end)
• S7 communication, as client	No
• S7 communication, as server	Yes
• Constant bus cycle time supported	Yes
• Isochronous mode	Yes, OB61

Technical specifications	
• Direct data exchange (cross-traffic)	Yes (as subscriber)
• SYNC/FREEZE	Yes
• Enable/disable DP slaves – Max. number of DP slaves that can be enabled/ disabled simultaneously	Yes 8
• DPV1	Yes
Transmission rate, max.	12 Mbps
Number of DP slaves, max.	124
Address range	
• Inputs, max.	2048 bytes
• Outputs, max.	2048 bytes
User data per DP slave	
• Inputs, max.	244 bytes
• Outputs, max.	244 bytes
DP slave	
Services	
• PG/OP communication	Yes
• Routing	Yes (only if interface is active)
• Global data communication	No
• S7 basic communication	No
• S7 communication	Yes (only server; connection configured at one end)
• S7 communication, as client	No
• S7 communication, as server	Yes
• Direct data exchange (cross-traffic)	Yes
• DPV1	No
Transmission rate, max.	12 Mbps
Automatic baud rate detection	Yes (only if interface is passive)
GSD file	The current GSD file is available for download at GSD file (http://www.siemens.com/profibus-gsd)
Transfer memory	
• Inputs	244 bytes
• Outputs	244 bytes
• Address areas, max.	32
• User data per address range, max.	32 bytes

Technical specifications	
Programming	
Programming language	
• LAD	Yes
• FBD	Yes
• STL	Yes
• SCL	Yes
• CFC	Yes
• GRAPH	Yes
• HiGraph®	Yes
Instruction set	
• Nesting levels	8
Know-how protection	
• User program/password security	Yes
• Block encryption	Yes, using S7-Block Privacy
System functions (SFC)	
See instruction list	
System function blocks (SFB)	
See instruction list	
Dimensions	
• Mounting dimensions W x H x D (mm)	40 x 125 x 130
• Weight	290 g
Voltages and currents	
• Power supply (rated value)	24 V DC
• Low limit of admissible range (DC)	19.2 V
• High limit of admissible range (DC)	28.8 V
• Current consumption (open-circuit), typically	150 mA
• Inrush current, typ.	3.5 A
• Current consumption (rated value)	850 mA
• I ² t	1 A ² s
• External protection of power supply lines (recommended), min.	2 A
• Power loss, typically	4.5 W

9.5 CPU 315-2 PN/DP

Technical specifications

Table 9- 6 Technical specifications of the CPU 315-2 PN/DP

Technical specifications	
CPU and version	
• MLFB	6ES7315-2EH14-0AB0
• Hardware version	01
• Firmware version	V3.2.1
• Associated programming package	STEP 7 as of V5.5 + HSP 199
Memory	
Main memory	
• Integrated	384 KB
• Expandable	No
• Maximum size of non-volatile memory for retentive data blocks,	128 KB
Load memory	
• Pluggable (MMC)	Yes
• Pluggable (MMC), max.	8 MB
• Data retention on the Micro Memory Card (after the last programming action), min.	10 years
Backup	
• Available	Yes (ensured with Micro Memory Card - maintenance-free)
• Without battery	Yes (program and data)
Execution times	
• for bit operation, min.	0.05 μ s
• for word operations, min.	0.09 μ s
• For fixed-point arithmetic, min.	0.12 μ s
• For floating-point arithmetic, min.	0.45 μ s
Timers/counters and their retentivity	
S7 counters	
• Number	256
Retentivity	
• Configurable	Yes
• Default	Z 0 to Z 7

Technical specifications	
Counting range	
• Low limit	0
• High limit	999
IEC counter	
• Available	Yes
• Type	SFB
• Number	Unlimited (limited only by main memory size)
S7 timers	
• Number	256
Retentivity	
• Configurable	Yes
• Default	No retentivity
Time setting range	
• Low limit	10 ms
• High limit	9990 s
IEC timer	
• Available	Yes
• Type	SFB
• Number	Unlimited (limited only by main memory size)
Data areas and their retentivity	
Bit memory	
• Number, max.	2048 bytes
• Retentivity, available	Yes (from MB 0 to MB 2047)
• Retentivity, default	MB 0 to MB 15
• Number of clock memories	8 (1 memory byte)
Data blocks	
• Number, max.	1024 (in the number range 1 to 16000)
• Size, max.	64 KB
• Retentivity, configurable	Yes, via non-retain feature on the DB
• Retentivity, default	Yes
Local data	
• Per priority class, max.	32 KB per execution level, 2 KB per block

Technical specifications	
Blocks	
• Number of blocks (total)	1024 (DBs, FCs, FBs) The maximum number of blocks that can be loaded may be reduced due to the Micro Memory Card you are using.
OB	See instruction list
• Size, max.	64 KB
• Number of free cycle OBs	1 (OB 1)
• Number of time-of-day interrupt OBs	1 (OB 10)
• Number of time-delay interrupt OBs	2 (OB 20, 21)
• Number of cyclic interrupt OBs	4 (OB 32, 33, 34, 35)
• Number of hardware interrupt OBs	1 (OB 40)
• Number of DPV1 interrupt OBs	3 (OB 55, 56, 57)
• Number of isochronous interrupt OBs	1 (OB 61)
• Number of restart OBs	1 (OB 100)
• Number of asynchronous error OBs	6 (OB 80, 82, 83, 85, 86, 87) (OB83 for PROFINET IO)
• Number of synchronous error OBs	2 (OB 121, 122)
Nesting depth	
• Per priority class	16
• Additionally within an error OB	4
FB	See instruction list
• Number, max.	1024 (in the number range 0 to 7999)
• Size	64 KB
FC	See instruction list
• Number, max.	1024 (in the number range 0 to 7999)
• Size	64 KB
Address ranges (inputs/outputs)	
I/O address area	
• Inputs	2048 bytes
• Outputs	2048 bytes
Distributed	
• Inputs	2048 bytes
• Outputs	2048 bytes
I/O process image	
• Inputs	2048 bytes

Technical specifications	
• Outputs	2048 bytes
• Inputs, adjustable	2048 bytes
• Outputs, adjustable	2048 bytes
• Inputs, preset	128 bytes
• Outputs, preset	128 bytes
Process image partitions	
• Number of partial process images, max.	1
• Amount of user data in the process image partition for isochronous PROFINET IO, max.	1600 bytes
Digital channels	
• Inputs	16384
• Outputs	16384
• Inputs, of those central	1024
• Outputs, of those central	1024
Analog channels	
• Inputs	1024
• Outputs	1024
• Inputs, of those central	256
• Outputs, of those central	256
Hardware configuration	
• Racks, max.	4
• Modules per rack, max.	8
Number of DP masters	
• Integrated	1
• Via CP	4
Number of usable FMs and CPs (recommended)	
• FM	8
• CP, point-to-point	8
• CP, LAN	10
Time	
Clock	
• Hardware clock (real-time)	Yes
• Buffered, can be synchronized	Yes
• Factory setting	DT#1994-01-01-00:00:00

Technical specifications	
• Buffered period	Typically 6 weeks (at an ambient temperature of 40 °C)
• Behavior of the clock on expiration of the buffered period	The clock continues at the time of day it had when power was switched off.
• Behavior of the real-time clock after POWER ON	The clock continues running after POWER OFF.
• Deviation per day, max.	10 s, typ. 2 s
Runtime meter	
• Number	1
• Number/number range	0
• Range of values	0 to 2 ³¹ hours (using the SFC 101)
• Granularity	1 hour
• Retentive	Yes; must be manually restarted after every restart
Clock synchronization	
• supported	Yes
• On MPI, master	Yes
• On MPI, slave	Yes
• On DP, master	Yes (DP slave must be time slave)
• On DP, slave	Yes
• On the AS, master	Yes
• On the AS, slave	Yes
• On Ethernet via NTP	Yes (as client)
S7 signaling functions	
• Number of stations that can be logged on for signaling functions, max.	16 (depends on the number of connections configured for PG/OP and S7 basic communication)
• Process error diagnostic messages	Yes
• Simultaneously enabled interrupt S blocks, max.	300
Test and startup functions	
Status/modify	
• Status/modify variable	Yes
• Variables	Inputs, outputs, bit memories, DBs, timers, counters
• Maximum number of variables	30
• of those status variables, max.	30

Technical specifications	
• Modify variables, max.	14
Forcing	
• Forcing	Yes
• Variables	Inputs, outputs
• Maximum number of tags	10
Status block	Yes (max. 2 blocks simultaneously)
Single step	Yes
• Number of breakpoints	4
Diagnostic buffer	
• Available	Yes
• No. of entries, max.	500
• Configurable	No
• of which are power-failure-proof	100, only the last 100 entries are retentive
• Maximum number of entries that can be read in RUN	499
• Number of entries that can be set in RUN	Yes (from 10 to 499)
• Number of preset entries in RUN	10
Service data	
• Can be read out	Yes
Monitoring function	
• Status LEDs	Yes
Communication functions	
PG/OP communication	Yes
Prioritized OCM communication	
• Supported	Yes
Routing	
• Number of routing connections	X1 as MPI max. 10; X1 as DP master max. 24 X1 as DP slave (active) max. 14 X2 as PROFINET max. 24
• Data record routing	Yes
Global data communication	
• Supported	Yes
• Number of GD circles, max.	8
• Number of GD packets, max.	8
• Number of GD packets, sender, max.	8
• Number of GD packets, receiver, max.	8

Technical specifications	
• Size of GD packets, max.	22 bytes
• Size of GD packets, of those consistent, max.	22 bytes
S7 basic communication	
• Supported	Yes
• User data per job, max.	76 bytes
• User data per job, consistent, max.	76 Bytes (for X-SEND/REC), 64 bytes (for X-PUT/GET as server)
S7 communication	
• Supported	Yes
• As server	Yes
• As client	Yes (via integrated PN interface and loadable FBs, or via CP and loadable FBs)
• User data per job	See the STEP 7 Online Help, <i>Common parameters of SFBs/FBs and SFC/FC of the S7 communication</i>
S5-compatible communication	
• Supported	Yes (via CP and loadable FCs)
Web server	
• Supported	Yes
• Number of HTTP clients	5
• User-defined web pages	Yes
Open IE communication	
• Supported	Yes
• Maximum number of connections/access points	8
• Local port number used at the system end	0, 20, 21, 23, 25, 102, 135, 161, 8080, 34962, 34963, 34964, 65532, 65533, 65534, 65535
TCP/IP	
• Maximum number of connections	8
• Data length for connection type 01 _H , max.	1460 bytes
• Data length for connection type 11 _H , max.	32768 bytes
• Multiple passive connections per port (multiport), supported	Yes
ISO on TCP	
• Maximum number of connections	8
• Data length, max.	32768 bytes

Technical specifications	
UDP	Yes (via integrated PROFINET interface and loadable FBs)
• Maximum number of connections	8
• Data length, max.	1472 bytes
iPAR server	
• Supported	Yes
Number of connections	
• Total	16
Suitable for PG communication	
• PG communication, reserved	1
• PG communication, configurable, min.	1
• PG communication, configurable, max.	15
Suitable for OP communication	
• OP communication, reserved	1
• OP communication, configurable, min.	1
• OP communication, configurable, max.	15
Suitable for S7 basic communication	
• S7 basic communication, reserved	0
• S7 basic communication, configurable, min.	0
• S7 basic communication, configurable, max.	14
Suitable for S7 communication	
• S7 communication, reserved	0
• S7 communication, configurable, min.	0
• S7 communication, configurable, max.	14
Total number of instances, max.	32
PROFINET CBA (with communication load setpoint)	
• Reference setting for CPU communication	50 %
• Number of remote interconnecting partners	32
• Number of master/slave functions	30
• Total of all master/slave connections	1000
• Data length of all incoming master/slave connections, max.	4000 bytes
• Data length of all outgoing master/slave connections, max.	4000 bytes
• Number of device-internal and PROFIBUS interconnections	500

Technical specifications	
• Data length of the device-internal and PROFIBUS interconnections, max.	4000 bytes
• Data length per connection, max.	1400 bytes
Remote interconnections with acyclic transmission	
• Sampling rate: Sampling time, min.	500 ms
• Number of incoming interconnections	100
• Number of outgoing interconnections	100
• Data length of all incoming interconnections, max.	2000 bytes
• Data length of all outgoing interconnections, max.	2000 bytes
• Data length per connection (acyclic interconnections), max.	1400 bytes
Remote interconnections with cyclic transmission	
• Transmission frequency: Minimum transmission interval	10 ms
• Number of incoming interconnections	200
• Number of outgoing interconnections	200
• Data length of all incoming interconnections, max.	2000 bytes
• Data length of all outgoing interconnections, max.	2000 bytes
• Data length per connection (acyclic interconnections), max.	450 bytes
HMI variables via PROFINET (acyclic)	
• HMI variables update	500 ms
• Number of stations that can be logged on for HMI variables (PN OPC/iMAP)	3, 2xPN OPC/1x iMAP
• Number of HMI variables	200
• Data length of all HMI variables, max.	2000 bytes
PROFIBUS proxy functionality	
• Supported	Yes
• Number of coupled PROFIBUS devices	16
• Data length per connection, max.	240 bytes (slave dependent)
Interfaces	
1st interface	
Interface designation	X1
Type of interface	Integrated RS 485 interface

Technical specifications	
Hardware	RS 485
• electrically disconnected	Yes
• Interface power supply (15 V DC to 30 V DC), max.	200 mA
Functionality	
• MPI	Yes
• DP master	Yes
• DP slave	Yes
• Point-to-point connection	No
MPI	
Services	
• PG/OP communication	Yes
• Routing	Yes
• Global data communication	Yes
• S7 basic communication	Yes
• S7 communication	Yes (server only; connection configured at one end)
• S7 communication, as client	No (but via CP and loadable FBs)
• S7 communication, as server	Yes
Transmission rate, max.	12 Mbps
DP master	
Services	
• PG/OP communication	Yes
• Routing	Yes
• Global data communication	No
• S7 basic communication	Yes (intelligent blocks only)
• S7 communication	Yes (server only; connection configured at one end)
• Constant bus cycle time supported	Yes
• Isochronous mode	Yes, OB 61 (isochronous mode can be used only alternatively on PROFIBUS DP or PROFINET IO)
• SYNC/FREEZE	Yes
• Activation/deactivation of DP slaves – Max. number of DP slaves that can be enabled / disabled simultaneously	Yes 8
• Direct data exchange (cross-traffic)	Yes (as subscriber)
• DPV1	Yes

Technical specifications	
Transmission rate, max.	12 Mbps
Number of DP slaves, max.	124
Address range	
• Inputs, max.	2 KB
• Outputs, max.	2 KB
User data per DP slave	
• Inputs, max.	244 bytes
• Outputs, max.	244 bytes
DP slave	
Services	
• PG/OP communication	Yes
• Routing	Yes (only if interface is active)
• Global data communication	No
• S7 basic communication	No
• S7 communication	Yes (server only; connection configured at one end)
• Direct data exchange (cross-traffic)	Yes
• DPV1	No
Transmission rate, max.	12 Mbps
Automatic baud rate detection	Yes (only if interface is passive)
Transfer memory	
• Inputs	244 bytes
• Outputs	244 bytes
• Address range, max.	32
• User data per address range, max.	32 bytes
GSD file	The current GSD file is available for download from the Internet (http://www.siemens.com/profibus-gsd).
2nd interface	
Interface designation	X2
Type of interface	PROFINET
Hardware	
• electrically disconnected	Yes
• Integrated switch	Yes
• Number of ports	2
• Automatic determination of the transmission rate	Yes (10/100 Mbps)
• Autonegotiation	Yes

Technical specifications	
• Autocrossing	Yes
Media redundancy	
• Supported	Yes
• Changeover time on line break, typically	200 ms (PROFINET MRP)
• Number of nodes on the ring, max.	50
Change of the IP address at runtime, supported	Yes
Keep-alive function, supported	Yes
Functionality	
• MPI	No
• DP master	No
• DP slave	No
• PROFINET IO controller	Yes, even simultaneously with IO device functionality
• PROFINET IO device	Yes, even simultaneously with IO controller functionality
• PROFINET CBA	Yes (acyclic and cyclic transmission)
• Open IE communication	Yes; via TCP/IP, ISO on TCP, UDP
• Web server	Yes
– Number of HTTP clients	5
PROFINET IO controller	
Services	
• PG/OP communication	Yes
• Routing	Yes
• S7 communication	Yes (with loadable FBs, max. configurable connections: 14; maximum number of instances: 32)
• Open IE communication	Yes; via TCP/IP, ISO on TCP, UDP
Number of integrated PROFINET IO controllers	1
RT, supported	Yes
IRT, supported	Yes
Transmission rate, max.	100 Mbps
Maximum number of connectable IO devices	128
Number of connectable IO devices, for RT, max.	128
• of which in line, max.	128
Number of IO devices with IRT and "high flexibility" option	128
• of which in line, max.	61
Number of IO devices with IRT and "high performance" option, max.	64

Technical specifications	
• of which in line, max.	64
Shared Device, supported	Yes
Isochronous mode	Yes (OB 61 - operation in isochronous mode is possible either on DP, or on PROFINET IO (not concurrently))
Prioritized startup, supported	Yes
• Maximum number of IO devices with prioritized startup	32
Activating/deactivating of PROFINET IO Devices	Yes
• Number of IO devices that can be enabled / disabled simultaneously, max.	8
IO devices changing during runtime (partner ports), supported	Yes
• Number of IO devices per tool, max.	8
Device replacement without removable medium	Yes
Send clocks	250 μ s, 500 μ s, 1 ms 2 ms, 4 ms (not for IRT with "high flexibility" option)
Update time	
• Update times	The minimum update time also depends on the time slice set for PROFINET IO communication, the number of IO Devices used, and on the amount of configured user data.
With RT	
• for send clock of 250 μ s	250 μ s to 128 ms
• for send clock of 500 μ s	500 μ s to 256 ms
• for send clock of 1 ms	1 ms to 512 ms
• for send clock of 2 ms	2 ms to 512 ms
• for send clock of 4 ms	4 ms to 512 ms
For IRT with "high flexibility" option	
• for send clock of 250 μ s	250 μ s to 128 ms
• for send clock of 500 μ s	500 μ s to 256 ms
• for send clock of 1 ms	1 ms to 512 ms
For IRT with "high performance" option	
• for send clock of 250 μ s	250 μ s to 4 ms
• for send clock of 500 μ s	500 μ s to 8 ms
• for send clock of 1 ms	1 ms to 16 ms
• for send clock of 2 ms	2 ms to 32 ms
• for send clock of 4 ms	4 ms to 64 ms

Technical specifications	
For IRT with "high performance" option and parameter assignment for "odd-numbered" send clocks	Update time = "odd-numbered" send clock set (any multiple of 125 µs: 375 µs, 625 µs to 3.875 ms)
Address range	
• Inputs, max.	2 KB
• Outputs, max.	2 KB
User data per address range, max.	
• User data consistency, max.	1024 bytes
PROFINET intelligent IO device	
Services	
• PG/OP communication	Yes
• S7 routing	Yes
• S7 communication	Yes (with loadable FBs, max. configurable connections: 14, maximum number of instances: 32)
• Open IE communication	Yes; via TCP/IP, ISO on TCP, UDP
RT, supported	Yes
IRT, supported	Yes
PROFenergy, supported	<i>Prepared with SFB 73 / 74 for loadable PROFenergy standard FBs for intelligent IO devices</i>
Shared Device, supported	Yes
• Number of IO controllers for shared devices, max.	2
Isochronous mode	No
Application transfer areas	Yes
IO devices transfer area	No
Transfer memory	
• Inputs, max.	1440 bytes, per controller for shared devices
• Outputs, max.	1440 bytes, per controller for shared devices
Submodules	
• Number, max.	64
• User data per submodule, max.	1024 bytes
Programming	
Programming language	
• LAD	Yes
• FBD	Yes
• STL	Yes
• SCL	Yes

Technical specifications	
• CFC	Yes
• GRAPH	Yes
• HiGraph®	Yes
Instruction set	See instruction list
• Nesting levels	8
Know-how protection	
• User program/password security	Yes
• Block encryption	Yes, using S7-Block Privacy
System functions (SFC)	See instruction list
System function blocks (SFB)	See instruction list
Dimensions	
• Mounting dimensions W x H x D (mm)	40 x 125 x 130
• Weight	340 g
Voltages and currents	
• Power supply (rated value)	24 V DC
• Low limit of admissible range (DC)	19.2 V
• High limit of admissible range (DC)	28.8 V
• Current consumption (open-circuit), typically	150 mA
• Current consumption (rated value)	750 mA
• Inrush current, typ.	4 A
• I ² t	1 A ² s
• External protection of power supply lines (recommended), min.	2 A
• Power loss, typically	4.65 W

ماكان كنترول

9.6 CPU 317-2 DP

Technical specifications

Table 9- 7 Technical specifications of the CPU 317-2 DP

Technical specifications	
CPU and version	
• MLFB	6ES7317-2AK14-0AB0
• Hardware version	01
• Firmware version	V3.3
• Associated programming package	STEP 7 as of V5.5 + SP1 or STEP 7 as of V5.2 + SP1 with HSP 202
Memory	
Main memory	
• Integrated	1 MB
• Expandable	No
• Maximum size of non-volatile memory for retentive data blocks	256 KB
Load memory	
• Pluggable (MMC)	Yes
• Pluggable (MMC), max.	8 MB
• Data retention on the Micro Memory Card (after the last programming action), min.	10 years
Backup	
• Available	Yes (ensured with Micro Memory Card - maintenance-free)
• Without battery	Yes (program and data)
Execution times	
• For bit operation, min.	0.025 μ s
• For word operations, min.	0.03 μ s
• For fixed-point arithmetic, min.	0.04 μ s
• For floating-point arithmetic, min.	0.16 μ s
Timers/counters and their retentivity	
S7 counters	
• Number	512
Retentivity	
• Configurable	Yes
• Default	Z 0 to Z 7

Technical specifications	
Counting range	
• Low limit	0
• High limit	999
IEC counter	
• Available	Yes
• Type	SFB
• Number	Unlimited (limited only by main memory size)
S7 timers	
• Number	512
Retentivity	
• Configurable	Yes
• Default	No retentivity
Time setting range	
• Low limit	10 ms
• High limit	9990 s
IEC timer	
• Available	Yes
• Type	SFB
• Number	Unlimited (limited only by main memory size)
Data areas and their retentivity	
Bit memory	
• Number, max.	4096 bytes
• Retentivity, available	Yes (MB 0 to MB 4095)
• Retentivity, default	MB 0 to MB 15
• Number of clock memories	8 (1 memory byte)
Data blocks	
• Number, max.	2048 (in the number range 1 to 16000)
• Size, max.	64 KB
• Retentivity, configurable	Yes, via non-retain feature on the DB
• Retentivity, default	Yes
Local data	
• Per priority class, max.	32 KB per execution level, 2 KB per block

Technical specifications	
Blocks	
• Number of blocks (total)	2048 (DBs, FCs, FBs) The maximum number of blocks that can be loaded may be reduced due to the Micro Memory Card you are using.
OB	
• Size, max.	64 KB
• Number of free cycle OBs	1 (OB 1)
• Number of time-of-day interrupt OBs	1 (OB 10)
• Number of time-delay interrupt OBs	2 (OB 20, 21)
• Number of cyclic interrupt OBs	4 (OB 32, 33, 34, 35)
• Number of hardware interrupt OBs	1 (OB 40)
• Number of DPV1 interrupt OBs	3 (OB 55, 56, 57)
• Number of isochronous interrupt OBs	1 (OB 61)
• Number of restart OBs	1 (OB 100)
• Number of asynchronous error OBs	5 (OB 80, 82, 85, 86, 87)
• Number of synchronous error OBs	2 (OB 121, 122)
Nesting depth	
• Per priority class	16
• Additionally within an error OB	4
FB	
See instruction list	
• Number, max.	2048 (in the number range 0 to 7999)
• Size, max.	64 KB
FC	
See instruction list	
• Number, max.	2048 (in the number range 0 to 7999)
• Size, max.	64 KB
Address ranges (inputs/outputs)	
I/O address area	
• Inputs, max.	8192 bytes (freely addressable)
• Outputs, max.	8192 bytes (freely addressable)
Distributed	
• Inputs	8192 bytes
• Outputs	8192 bytes
I/O process image	
• Inputs	8192 bytes

Technical specifications	
• Outputs	8192 bytes
• Inputs, adjustable	8192 bytes
• Outputs, adjustable	8192 bytes
• Inputs, preset	256 bytes
• Outputs, preset	256 bytes
Process image partitions	
• Number of partial process images, max.	1
Digital channels	
• Inputs, max.	65636
• Outputs, max.	65636
• Inputs, of those central	1024
• Outputs, of those central	1024
Analog channels	
• Inputs, max.	4096
• Outputs, max.	4096
• Inputs, of those central, max.	256
• Outputs, of those central, max.	256
Hardware configuration	
• Racks, max.	4
• Modules per rack, max.	8
Number of DP masters	
• Integrated	2
• Via CP	4
Number of usable FMs and CPs (recommended)	
• FM	8
• CP, point-to-point	8
• CP, LAN	10
Time-of-day	
Clock	
• Hardware clock (real-time)	Yes
• Buffered, can be synchronized	Yes
• Factory setting	DT#1994-01-01-00:00:00
• Buffered period	Typically 6 weeks (at an ambient temperature of 40 °C)

Technical specifications	
• Behavior of the real-time clock after POWER ON	The clock continues running after POWER OFF
• Behavior after expiration of the buffered period	The clock continues at the time of day it had when power was switched off.
• Deviation per day, max.	10 s, typ. 2 s
Runtime meter	
• Number	4
• Number/number range	0 to 3
• Range of values	0 to 2 ³¹ hours (using the SFC 101)
• Granularity	1 hour
• Retentive	Yes; must be manually restarted after every restart
Clock synchronization	
• Supported	Yes
• On MPI, master	Yes
• On MPI, slave	Yes
• On DP, master	Yes (DP slave must be time slave)
• On DP, slave	Yes
• On the AS, master	Yes
• On the AS, slave	Yes
S7 signaling functions	
• Number of stations that can be logged on for signaling functions, max.	32 (depends on the number of connections configured for PG/OP and S7 basic communication)
• Process error diagnostic messages	Yes
• Simultaneously enabled interrupt S blocks, max.	300
Test and startup functions	
Status/modify	
• Status/modify variable	Yes
• Variables	Inputs, outputs, bit memories, DBs, timers, counters
• Maximum number of variables	30
• Status variables, max.	30
• Modify variables, max.	14

Technical specifications	
Forcing	
• Forcing	Yes
• Variables	Inputs, outputs
• Maximum number of tags	10
Status block	Yes (max. 2 blocks simultaneously)
Single step	
• Number of breakpoints	4
Diagnostic buffer	
• Available	Yes
• Maximum number of entries	500
• Configurable	No
• Of which are power-failure-proof	100, only the last 100 entries are retentive
• Maximum number of entries that can be read in RUN	499
• Number of entries that can be set in RUN	Yes (from 10 to 499)
• Number of preset entries in RUN	10
Service data	
• Can be read out	Yes
Monitoring function	
• Status LEDs	Yes
Communication functions	
PG/OP communication	Yes
Prioritized OCM communication	
• Supported	Yes
Routing	
• Number of routing connections	X1 as MPI max. 10 X1 as DP master max. 24 X1 as DP slave (active) max. 14 X2 as DP master max. 24 X2 as DP slave (active) max. 14
• Data record routing	Yes
Global data communication	
• Supported	Yes
• Number of GD circles, max.	8
• Number of GD packets, max.	8
• Number of GD packets, sender, max.	8
• Number of GD packets, receiver, max.	8

Technical specifications	
• Size of GD packets, max.	22 bytes
• Size of GD packets, of those consistent, max.	22 bytes
S7 basic communication	
• Supported	Yes
• User data per job, max.	76 bytes
• User data per job, consistent, max.	76 bytes (for X_SEND/RCV); 76 bytes (for X_PUT/GET as server)
S7 communication	
• Supported	Yes
• As server	Yes
• As client	Yes (via CP and loadable FBs)
• User data per job, max.	180 bytes (for PUT/GET)
• User data per job, consistent, max.	240 bytes (as server)
S5-compatible communication	
• Supported	Yes (via CP and loadable FCs)
Number of connections	
• Total	32
Suitable for PG communication	
• PG communication, reserved	1
• PG communication, configurable, min.	1
• PG communication, configurable, max.	31
Suitable for OP communication	
• OP communication, reserved	1
• OP communication, configurable, min.	1
• OP communication, configurable, max.	31
Suitable for S7 basic communication	
• S7 basic communication, reserved	0
• S7 basic communication, configurable, min.	0
• S7 basic communication, configurable, max.	30
Interfaces	
1st interface	
Interface designation	X1
Type of interface	Integrated RS 485 interface
Hardware	RS 485
• electrically disconnected	Yes

Technical specifications	
• Interface power supply (15 V DC to 30 V DC), max.	200 mA
Functionality	
• MPI	Yes
• DP master	Yes
• DP slave	Yes
• Point-to-point connection	No
MPI	
Services	
• PG/OP communication	Yes
• Routing	Yes
• Global data communication	Yes
• S7 basic communication	Yes
• S7 communication	Yes (server only; connection configured at one end)
• S7 communication, as client	No
• S7 communication, as server	Yes
Transmission rate, max.	12 Mbps
DP master	
Services	
• PG/OP communication	Yes
• Routing	Yes
• Global data communication	No
• S7 basic communication	Yes (intelligent blocks only)
• S7 communication	Yes (server only; connection configured at one end)
• Constant bus cycle time supported	Yes
• Isochronous mode	No
• SYNC/FREEZE	Yes
• Activate/deactivate DP slaves – Max. number of DP slaves that can be enabled / disabled simultaneously	Yes 8
• Direct data exchange (cross-traffic)	Yes (as subscriber)
• DPV1	Yes
Transmission rate, max.	12 Mbps
Number of DP slaves	124
Address range	

Technical specifications	
• Inputs, max.	8192 bytes
• Outputs, max.	8192 bytes
User data per DP slave	
• Inputs, max.	244 bytes
• Outputs, max.	244 bytes
DP slave (DP slave at both DP interfaces is excluded)	
Services	
• PG/OP communication	Yes
• Routing	Yes (only if interface is active)
• Global data communication	No
• S7 basic communication	No
• S7 communication	Yes (server only; connection configured at one end)
• Direct data exchange (cross-traffic)	Yes
• DPV1	No
Transmission rate, max.	12 Mbps
Automatic baud rate detection	Yes (only if interface is passive)
Transfer memory	
• Inputs	244 bytes
• Outputs	244 bytes
• Address range, max.	32
• User data per address range, max.	32 bytes
GSD file	The current GSD file is available for download from the Internet (http://www.siemens.com/profibus-gsd).
2nd interface	
Interface designation	X2
Type of interface	Integrated RS 485 interface
Hardware	RS 485
• electrically disconnected	Yes
• Interface power supply (15 V DC to 30 V DC), max.	200 mA
Functionality	
• MPI	No
• DP master	Yes
• DP slave	Yes
• Point-to-point connection	No

Technical specifications	
DP master	
Services	
• PG/OP communication	Yes
• Routing	Yes
• Global data communication	No
• S7 basic communication	Yes (intelligent blocks only)
• S7 communication	Yes (server only; connection configured at one end)
• S7 communication, as client	No
• S7 communication, as server	Yes
• Constant bus cycle time supported	Yes
• Isochronous mode	Yes (OB61)
• Direct data exchange (cross-traffic)	Yes (as subscriber)
• SYNC/FREEZE	Yes
• Activate/deactivate DP slaves	Yes
– Max. number of DP slaves that can be enabled / disabled simultaneously	8
• DPV1	Yes
Transmission rate, max.	12 Mbps
Number of DP slaves, max.	124
Address range	
• Inputs, max.	8192 bytes
• Outputs, max.	8192 bytes
User data per DP slave	
• Inputs, max.	244 bytes
• Outputs, max.	244 bytes
DP slave (DP slave at both DP interfaces is excluded)	
Services	
• PG/OP communication	Yes
• Routing	Yes (only if interface is active)
• Global data communication	No
• S7 basic communication	No
• S7 communication	Yes (server only, connections configured at one end)
• S7 communication, as client	No
• S7 communication, as server	Yes

Technical specifications	
• Direct data exchange (cross-traffic)	Yes
• DPV1	No
Transmission rate, max.	12 Mbps
Automatic baud rate detection	Yes (only if interface is passive)
GSD file	The current GSD file is available for download from the Internet (http://www.siemens.com/profibus-gsd).
Transfer memory	
• Inputs	244 bytes
• Outputs	244 bytes
• Address range, max.	32
• User data per address range, max.	32 bytes
Programming	
Programming language	
• LAD	Yes
• FBD	Yes
• STL	Yes
• SCL	Yes
• CFC	Yes
• GRAPH	Yes
• HiGraph®	Yes
Instruction set	
• Nesting levels	8
Know-how protection	
• User program/password security	Yes
• Block encryption	Yes, using S7-Block Privacy
System functions (SFC)	
System function blocks (SFB)	
Dimensions	
• Mounting dimensions W x H x D (mm)	40 x 125 x 130
• Weight	360 g
Voltages and currents	
• Power supply (rated value)	24 V DC
• Low limit of admissible range (DC)	19.2 V
• High limit of admissible range (DC)	28.8 V
• Current consumption (open-circuit), typically	120 mA

Technical specifications	
• Current consumption (rated value)	870 mA
• Inrush current, typ.	4 A
• I ² t	1 A ² s
• External protection of power supply lines (recommended), min.	2 A
• Power loss, typically	4.5 W

9.7 CPU 317-2 PN/DP

Technical specifications

Table 9- 8 Technical specifications of the CPU 317-2 PN/DP

Technical specifications	
CPU and version	
• MLFB	6ES7317-2EK14-0AB0
• Hardware version	01
• Firmware version	V3.2.1
• Associated programming package	STEP 7 as of V5.5 + HSP 199
Memory	
Main memory	
• Integrated	1 MB
• Expandable	No
• Maximum size of non-volatile memory for retentive data blocks	256 KB
Load memory	
• Pluggable (MMC)	Yes
• Pluggable (MMC), max.	8 MB
• Data retention on the Micro Memory Card (after the last programming action), min.	10 years
Backup	
• Available	Yes (ensured with Micro Memory Card - maintenance-free)
• Without battery	Yes (program and data)

Technical specifications	
Execution times	
• For bit operation, min.	0.025 µs
• For word operations, min.	0.03 µs
• For fixed-point arithmetic, min.	0.04 µs
• For floating-point arithmetic, min.	0.16 µs
Timers/counters and their retentivity	
S7 counters	
• Number	512
Retentivity	
• Configurable	Yes
• Default	Z 0 to Z 7
Counting range	
• Low limit	0
• High limit	999
IEC counter	
• Available	Yes
• Type	SFB
• Number	Unlimited (limited only by main memory size)
S7 timers	
• Number	512
Retentivity	
• Configurable	Yes
• Default	No retentivity
Time setting range	
• Low limit	10 ms
• High limit	9990 s
IEC timer	
• Available	Yes
• Type	SFB
• Number	Unlimited (limited only by main memory size)
Data areas and their retentivity	
Bit memory	
• Number, max.	4096 bytes
• Retentivity, available	Yes (from MB 0 to MB 4095)
• Retentivity, default	MB 0 to MB 15

Technical specifications	
• Number of clock memories	8 (1 memory byte)
Data blocks	
• Number, max.	2048 (in the number range 1 to 16000)
• Size, max.	64 KB
• Retentivity, configurable	Yes, via non-retain feature on the DB
• Retentivity, default	Yes
Local data	
• Per priority class, max.	32 KB per execution level, 2 KB per block
Blocks	
• Number of blocks (total)	2048 (DBs, FCs, FBs) The maximum number of blocks that can be loaded may be reduced due to the Micro Memory Card you are using.
OB	
• Size, max.	64 KB
• Number of free cycle OBs	1 (OB 1)
• Number of time-of-day interrupt OBs	1 (OB 10)
• Number of time-delay interrupt OBs	2 (OB 20, 21)
• Number of cyclic interrupt OBs	4 (OB 32, 33, 34, 35)
• Number of hardware interrupt OBs	1 (OB 40)
• Number of DPV1 interrupt OBs	3 (OB 55, 56, 57)
• Number of isochronous interrupt OBs	1 (OB 61)
• Number of restart OBs	1 (OB100)
• Number of asynchronous error OBs	6 (OB 80, 82, 83, 85, 86, 87) (OB83 for PROFINET IO)
• Number of synchronous error OBs	2 (OB 121, 122)
Nesting depth	
• Per priority class	16
• Additionally within an error OB	4
FB	
• Number, max.	2048 (in the number range 0 to 7999)
• Size	64 KB
FC	
• Number, max.	2048 (in the number range 0 to 7999)

Technical specifications	
• Size	64 KB
Address ranges (inputs/outputs)	
I/O address area	
• Inputs	8192 bytes
• Outputs	8192 bytes
Distributed	
• Inputs	8192 bytes
• Outputs	8192 bytes
I/O process image	
• Inputs	8192 bytes
• Outputs	8192 bytes
• Inputs, adjustable	8192 bytes
• Outputs, adjustable	8192 bytes
• Inputs, preset	256 bytes
• Outputs, preset	256 bytes
Process image partitions	
• Number of partial process images, max.	1
• Amount of user data in the process image partition for isochronous PROFINET IO, max.	1600 bytes
Digital channels	
• Inputs	65536
• Outputs	65536
• Inputs, of those central	1024
• Outputs, of those central	1024
Analog channels	
• Inputs	4096
• Outputs	4096
• Inputs, of those central	256
• Outputs, of those central	256
Hardware configuration	
• Racks, max.	4
• Modules per rack, max.	8
Number of DP masters	
• Integrated	1
• Via CP	4

Technical specifications	
Number of usable FMs and CPs (recommended)	
• FM	8
• CP, point-to-point	8
• CP, LAN	10
Time-of-day	
Clock	
• Hardware clock (real-time)	Yes
• Buffered, can be synchronized	Yes
• Factory setting	DT#1994-01-01-00:00:00
• Buffered period	Typically 6 weeks (at an ambient temperature of 40 °C)
• Behavior of the clock on expiration of the buffered period	The clock continues at the time of day it had when power was switched off.
• Behavior of the real-time clock after POWER ON	The clock continues running after POWER OFF.
• Deviation per day, max.	10 s, typ. 2 s
Runtime meter	
• Number	4
• Number/number range	0 to 3
• Range of values	0 to 2 ³¹ hours (using the SFC 101)
• Granularity	1 hour
• Retentive	Yes; must be manually restarted after every restart
Clock synchronization	
• Supported	Yes
• On MPI, master	Yes
• On MPI, slave	Yes
• On DP, master	Yes (DP slave must be time slave)
• On DP, slave	Yes
• On the AS, master	Yes
• On the AS, slave	Yes
• On Ethernet via NTP	Yes (as client)
S7 signaling functions	
• Number of stations that can be logged on for signaling functions, max.	32 (depends on the number of connections configured for PG/OP and S7 basic communication)

Technical specifications	
• Process error diagnostic messages	Yes
• Simultaneously enabled interrupt S blocks, max.	300
Test and startup functions	
Status/modify	
• Status/modify variable	Yes
• Variables	Inputs, outputs, bit memories, DBs, timers, counters
• Maximum number of variables	30
• Status variables, max.	30
• Modify variables, max.	14
Forcing	
• Forcing	Yes
• Variables	Inputs, outputs
• Maximum number of tags	10
Status block	Yes (max. 2 blocks simultaneously)
Single step	Yes
• Number of breakpoints	4
Diagnostic buffer	
• Available	Yes
• No. of entries, max.	500
• Configurable	No
• Of which are power-failure-proof	100, only the last 100 entries are retentive
• Maximum number of entries that can be read in RUN	499
• Number of entries that can be set in RUN	Yes (from 10 to 499)
• Number of preset entries in RUN	10
Service data	
• Can be read out	Yes
Monitoring function	
• Status LEDs	Yes
Communication functions	
PG/OP communication	Yes
Prioritized OCM communication	
• Supported	Yes
Routing	Yes

Technical specifications	
• Number of routing connections	X1 as MPI max. 10; X1 as DP master max. 24 X1 as DP slave (active) max. 24 X2 as PROFINET max. 24
• Data record routing	Yes
Global data communication	
• Supported	Yes
• Number of GD circles, max.	8
• Number of GD packets, max.	8
• Number of GD packets, sender, max.	8
• Number of GD packets, receiver, max.	8
• Size of GD packets, max.	22 bytes
• Size of GD packets, of those consistent, max.	22 bytes
S7 basic communication	
• Supported	Yes
• User data per job, max.	76 bytes
• User data per job, consistent, max.	76 bytes (for X-SEND/REC); 64 bytes (for X-PUT/GET as server)
S7 communication	
• Supported	Yes
• As server	Yes
• As client	Yes (via integrated PN interface and loadable FBs, or via CP and loadable FBs)
• User data per job	See the STEP 7 Online Help, <i>Common parameters of SFBs/FBs and SFC/FC of the S7 communication</i>
S5-compatible communication	
• Supported	Yes (via CP and loadable FCs)
Web server	
• Supported	Yes
• Number of HTTP clients	5
• User-defined web pages	Yes
Open IE communication	
• Supported	Yes
• Maximum number of connections/access points	16
• Local port number used at the system end	0, 20, 21, 23, 25, 80, 102, 135, 161, 8080, 34962, 34963, 34964, 65532, 65533, 65534, 65535

Technical specifications	
TCP/IP	Yes (via integrated PROFINET interface and loadable FBs)
• Maximum number of connections	16
• Data length for connection type 01 _H , max.	1460 bytes
• Data length for connection type 11 _H , max.	32768 bytes
• Multiple passive connections per port (multiport), Supported	Yes
ISO on TCP	Yes (via integrated PROFINET interface and loadable FBs)
• Maximum number of connections	16
• Data length, max.	32768 bytes
UDP	Yes (via integrated PROFINET interface and loadable FBs)
• Maximum number of connections	16
• Data length, max.	1472 bytes
iPAR server	
• Supported	Yes
Number of connections	
• Total	32
Suitable for PG communication	31
• PG communication, reserved	1
• PG communication, configurable, min.	1
• PG communication, configurable, max.	31
Suitable for OP communication	31
• OP communication, reserved	1
• OP communication, configurable, min.	1
• OP communication, configurable, max.	31
Suitable for S7 basic communication	30
• S7 basic communication, reserved	0
• S7 basic communication, configurable, min.	0
• S7 basic communication, configurable, max.	30
Suitable for S7 communication	16
• S7 communication, reserved	0
• S7 communication, configurable, min.	0
• S7 communication, configurable, max.	16
Total number of instances, max.	32

Technical specifications	
PROFINET CBA (with communication load setpoint)	
• Reference setting for CPU communication	50 %
• Number of remote interconnecting partners	32
• Number of master/slave functions	30
• Total of all master/slave connections	1000
• Data length of all incoming master/slave connections, max.	4000 bytes
• Data length of all outgoing master/slave connections, max.	4000 bytes
• Number of device-internal and PROFIBUS interconnections	500
• Data length of the device-internal and PROFIBUS interconnections, max.	4000 bytes
• Data length per connection, max.	1400 bytes
Remote interconnections with acyclic transmission	
• Sampling rate: Sampling time, min.	500 ms
• Number of incoming interconnections	100
• Number of outgoing interconnections	100
• Data length of all incoming interconnections, max.	2000 bytes
• Data length of all outgoing interconnections, max.	2000 bytes
• Data length per connection (acyclic interconnections), max.	1400 bytes
Remote interconnections with cyclic transmission	
• Transmission frequency: Minimum transmission interval	10 ms
• Number of incoming interconnections	200
• Number of outgoing interconnections	200
• Data length of all incoming interconnections, max.	2000 bytes
• Data length of all outgoing interconnections, max.	2000 bytes
• Data length per connection (acyclic interconnections), max.	450 bytes
HMI variables via PROFINET (acyclic)	
• HMI variables update	500 ms

Technical specifications	
• Number of stations that can be logged on for HMI variables (PN OPC/iMAP)	3 (2 x PN OPC/1 x iMAP)
• Number of HMI variables	200
• Data length of all HMI variables, max.	2000 bytes
PROFIBUS proxy functionality	
• Supported	Yes
• Number of coupled PROFIBUS devices	16
• Data length per connection, max.	240 bytes (slave dependent)
Interfaces	
1st interface	
Interface designation	X1
Type of interface	Integrated RS 485 interface
Hardware	RS 485
• electrically disconnected	Yes
• Interface power supply (15 V DC to 30 V DC), max.	200 mA
Functionality	
• MPI	Yes
• DP master	Yes
• DP slave	Yes
• Point-to-point connection	No
• PROFINET	No
MPI	
Services	
• PG/OP communication	Yes
• Routing	Yes
• Global data communication	Yes
• S7 basic communication	Yes
• S7 communication	Yes (server only, connections configured at one end)
• S7 communication, as client	No (but via CP and loadable FBs)
• S7 communication, as server	Yes
Transmission rate, max.	12 Mbps
DP master	
Services	
• PG/OP communication	Yes
• Routing	Yes

Technical specifications	
• Global data communication	No
• S7 basic communication	Yes (intelligent blocks only)
• S7 communication	Yes (server only; connection configured at one end)
• Constant bus cycle time supported	Yes
• Isochronous mode	Yes (OB 61 - operation in isochronous mode is possible either on DP, or on PROFINET IO (not concurrently))
• SYNC/FREEZE	Yes
• Activate/deactivate DP slaves	Yes
• Max. number of DP slaves that can be enabled / disabled simultaneously	8
• Direct data exchange (cross-traffic)	Yes (as subscriber)
• DPV1	Yes
Transmission rate, max.	12 Mbps
Number of DP slaves, max.	124
Address range	
• Inputs, max.	8 KB
• Outputs, max.	8 KB
User data per DP slave	
• Inputs, max.	244 bytes
• Outputs, max.	244 bytes
DP slave	
Services	
• PG/OP communication	Yes
• Routing	Yes (only if interface is active)
• Global data communication	No
• S7 basic communication	No
• S7 communication	Yes (server only; connection configured at one end)
• Direct data exchange (cross-traffic)	Yes
• DPV1	No
Transmission rate, max.	12 Mbps
Automatic baud rate detection	Yes (only if interface is passive)
Transfer memory	
• Inputs	244 bytes
• Outputs	244 bytes

Technical specifications	
• Address areas, max.	32
• User data per address range, max.	32 bytes
GSD file	The current GSD file is available for download from the Internet (http://www.siemens.com/profibus-gsd).
2nd interface	
Interface designation	X2
Type of interface	PROFINET
Hardware	Ethernet RJ 45
• electrically disconnected	Yes
• Integrated switch	Yes
• Number of ports	2
• Automatic determination of the transmission rate	Yes (10/100 Mbps)
• Autonegotiation	Yes
• Autocrossing	Yes
Media redundancy	
• Supported	Yes
• Changeover time on line break, typically	200 ms (PROFINET MRP)
• Number of nodes on the ring, max.	50
Change of the IP address at runtime, supported	Yes
Keep-alive function, supported	Yes
Functionality	
• MPI	No
• DP master	No
• DP slave	No
• PROFINET IO controller	Yes, even simultaneously with IO device functionality
• PROFINET IO device	Yes, even simultaneously with IO controller functionality
• PROFINET CBA	Yes (acyclic and cyclic transmission)
• Open IE communication	Yes; via TCP/IP, ISO on TCP, UDP
• Web server	Yes
– Number of HTTP clients	5
PROFINET IO controller	
Services	
• PG/OP communication	Yes
• Routing	Yes

Technical specifications	
• S7 communication	Yes (with loadable FBs, max. configurable connections: 16; maximum number of instances: 32)
• Open IE communication	Yes; via TCP/IP, ISO on TCP, UDP
Number of integrated PROFINET IO controllers	1
RT, supported	Yes
IRT, supported	Yes
Transmission rate, max.	100 Mbps
Maximum number of connectable IO devices	128
Number of connectable IO devices, for RT, max.	128
• of which in line, max.	128
Number of IO devices with IRT and "high flexibility" option	128
• of which in line, max.	61
Number of IO devices with IRT and "high performance" option, max.	64
• of which in line, max.	64
Shared Device, supported	Yes
Isochronous mode	Yes (OB 61, isochronous mode can be used only alternatively on PROFIBUS DP or PROFINET IO)
Prioritized startup, supported	Yes
• Maximum number of IO devices with prioritized startup	32
Activating/deactivating PROFINET IO devices	Yes
• Number of IO devices that can be enabled / disabled simultaneously, max.	8
IO devices changing during runtime (partner ports), supported	Yes
• Number of IO devices per tool, max.	8
Device replacement without removable medium	Yes
Send clocks	250 μ s, 500 μ s, 1 ms 2 ms, 4 ms (not for IRT with "high flexibility" option)
Update time	
• Update times	The minimum update time also depends on the time slice set for PROFINET IO communication, the number of IO Devices used, and on the amount of configured user data.
With RT	
• for send clock of 250 μ s	250 μ s to 128 ms
• for send clock of 500 μ s	500 μ s to 256 ms
• for send clock of 1 ms	1 ms to 512 ms

Technical specifications	
• for send clock of 2 ms	2 ms to 512 ms
• for send clock of 4 ms	4 ms to 512 ms
For IRT with "high flexibility" option	
• For send clock of 250 µs	250 µs to 128 ms
• For send clock of 500 µs	500 µs to 256 ms
• For send clock of 1 ms	1 ms to 512 ms
For IRT with "high performance" option	
• for send clock of 250 µs	250 µs to 4 ms
• for send clock of 500 µs	500 µs to 8 ms
• for send clock of 1 ms	1 ms to 16 ms
• for send clock of 2 ms	2 ms to 32 ms
• for send clock of 4 ms	4 ms to 64 ms
For IRT with "high performance" option and parameter assignment for "odd-numbered" send clocks	Update time = "odd-numbered" send clock set (any multiple of 125 µs: 375 µs, 625 µs to 3.875 ms)
Address range	
• Inputs, max.	8 KB
• Outputs, max.	8 KB
User data per address range, max.	
• User data consistency, max.	1024 bytes
PROFINET intelligent IO device	
Services	
• PG/OP communication	Yes
• S7 routing	Yes
• S7 communication	Yes (with loadable FBs, max. configurable connections: 16, maximum number of instances: 32)
• Open IE communication	Yes; via TCP/IP, ISO on TCP, UDP
RT, supported	Yes
IRT, supported	Yes
PROFenergy, supported	<i>Prepared with SFB 73 / 74 for loadable PROFenergy standard FBs for intelligent IO devices</i>
Shared Device, supported	Yes
• Number of IO controllers for shared devices, max.	2
Isochronous mode	No
Application transfer areas	Yes
IO devices transfer area	No

Technical specifications	
Transfer memory	
• Inputs, max.	1440 bytes; per controller for shared devices
• Outputs, max.	1440 bytes; per controller for shared devices
Submodules	
• Number, max.	64
• User data per submodule, max.	1024 bytes
Programming	
Programming language	
• LAD	Yes
• FBD	Yes
• STL	Yes
• SCL	Yes
• CFC	Yes
• GRAPH	Yes
• HiGraph®	Yes
Instruction set	
• Nesting levels	8
Know-how protection	
• User program/password security	Yes
• Block encryption	Yes, using S7-Block Privacy
System functions (SFC)	
See instruction list	
System function blocks (SFB)	
See instruction list	
Dimensions	
• Mounting dimensions W x H x D (mm)	40 x 125 x 130
• Weight	340 g
Voltages and currents	
• Power supply (rated value)	24 V DC
• Low limit of admissible range (DC)	19.2 V
• High limit of admissible range (DC)	28.8 V
• Current consumption (open-circuit), typically	150 mA
• Current consumption (rated value)	750 mA
• Inrush current, typ.	4 A
• I ² t	1 A ² s
• External protection of power supply lines (recommended), min.	2 A
• Power loss, typically	4.65 W

9.8 CPU 319-3 PN/DP

Technical specifications

Table 9- 9 Technical specifications of the CPU 319-3 PN/DP

Technical specifications	
CPU and version	
• MLFB	6ES7318-3EL01-0AB0
• Hardware version	01
• Firmware version	V3.2.1
• Associated programming package	STEP 7 V5.5 or higher
Memory	
Main memory	
• Integrated	2048 KB
• Expandable	No
• Maximum size of non-volatile memory for retentive data blocks,	700 KB
Load memory	
• Pluggable (MMC)	Yes
• Pluggable (MMC), max.	8 MB
• Data retention on the Micro Memory Card (after the last programming action), min.	10 years
Backup	
• Available	Yes (ensured with Micro Memory Card - maintenance-free)
• Without battery	Yes (program and data)
Execution times	
• For bit operations, min.	0.004 μ s
• For word operations, min.	0.01 μ s
• for fixed-point arithmetic, min.	0.01 μ s
• for floating-point arithmetic, min.	0.04 μ s
Timers/counters and their retentivity	
S7 counters	
• Number	2048
Retentivity	
• Configurable	Yes
• Default	Z 0 to Z 7

Technical specifications	
Counting range	
• Low limit	0
• High limit	999
IEC counter	
• Available	Yes
• Type	SFB
• Number	Unlimited (limited only by main memory size)
S7 timers	
• Number	2048
Retentivity	
• Configurable	Yes
• Default	No retentivity
Time setting range	
• Low limit	10 ms
• High limit	9990 s
IEC timer	
• Available	Yes
• Type	SFB
• Number	Unlimited (limited only by main memory size)
Data areas and their retentivity	
Bit memory	
• Number, max.	8192 bytes
• Retentivity, available	Yes (MB 0 to MB 8191)
• Retentivity, default	MB 0 to MB 15
• Number of clock memories	8 (1 memory byte)
Data blocks	
• Number, max.	4096 (in the number range 1 to 16000)
• Size, max.	64 KB
• Retentivity, configurable	Yes, via non-retain feature on the DB
• Retentivity, default	Yes
Local data	
• Per priority class, max.	32 KB per execution level, 2 KB per block

Technical specifications	
Blocks	
• Number of blocks (total)	4096 (DBs, FCs, FBs) The maximum number of blocks that can be loaded may be reduced due to the Micro Memory Card you are using.
OB	
• Size, max.	64 KB
• Number of free cycle OBs	1 (OB 1)
• Number of time-of-day interrupt OBs	1 (OB 10)
• Number of time-delay interrupt OBs	2 (OB 20, 21)
• Number of cyclic interrupt OBs	4 (OB 32, 33, 34, 35) (OB 35 as of 500 µs)
• Number of hardware interrupt OBs	1 (OB 40)
• Number of DPV1 interrupt OBs (only DP CPUs)	3 (OB 55, 56, 57)
• Number of isochronous interrupt OBs	1 (OB 61)
• Number of asynchronous error OBs	6 (OB 80, 82, 83, 85, 86, 87) (OB 83 only for PROFINET IO)
• Number of restart OBs	1 (OB 100)
• Number of synchronous error OBs	2 (OB 121, 122)
Nesting depth	
• Per priority class	16
• Additionally within an error OB	4
FB	
• Number, max.	4096 (number range from 0 to 7999)
• Size, max.	64 KB
FC	
• Number, max.	4096 (number range from 0 to 7999)
• Size, max.	64 KB
Address ranges (inputs/outputs)	
I/O address area	
• Inputs	8192 bytes
• Outputs	8192 bytes
Distributed	
• Inputs	8192 bytes
• Outputs	8192 bytes
I/O process image	

Technical specifications	
• Inputs	8192 bytes
• Outputs	8192 bytes
• Inputs, adjustable	8192 bytes
• Outputs, adjustable	8192 bytes
• Inputs, preset	256 bytes
• Outputs, preset	256 bytes
Process image partitions	
• Number of partial process images, max.	1
• Amount of user data in the process image partition for isochronous PROFINET IO, max.	1600 bytes
Digital channels	
• Inputs	65536
• Outputs	65536
• Inputs, of those central	1024
• Outputs, of those central	1024
Analog channels	
• Inputs	4096
• Outputs	4096
• Inputs, of those central	256
• Outputs, of those central	256
Hardware configuration	
• Racks, max.	4
• Modules per rack, max.	8
Number of DP masters	
• Integrated	2
• Via CP	4
Number of usable FMs and CPs (recommended)	
• FM	8
• CP, point-to-point	8
• CP, LAN	10
Time-of-day	
Clock	
• Hardware clock (real-time)	Yes
• Buffered, can be synchronized	Yes
• Factory setting	DT#1994-01-01-00:00:00

Technical specifications	
• Buffered period	Typically 6 weeks (at an ambient temperature of 40 °C)
• Behavior of the clock on expiration of the buffered period	The clock continues at the time of day it had when power was switched off.
• Behavior of the real-time clock after POWER ON	The clock continues running after POWER OFF.
• Deviation per day, max.	10 s, typ. 2 s
Runtime meter	
• Number	4
• Number/number range	0 to 3
• Range of values	0 to 2 ³¹ hours (using the SFC 101)
• Granularity	1 hour
• Retentive	Yes; must be manually restarted after every restart
Clock synchronization	
• supported	Yes
• On MPI, master	Yes
• On MPI, slave	Yes
• On DP, master	Yes (DP slave must be time slave)
• On DP, slave	Yes
• On the AS, master	Yes
• On the AS, slave	Yes
• On Ethernet via NTP	Yes (as client)
S7 signaling functions	
• Number of stations that can be logged on for signaling functions, max.	32 (depends on the number of connections configured for PG/OP and S7 basic communication)
• Process error diagnostic messages	Yes
• Simultaneously enabled interrupt S blocks, max.	300
Test and startup functions	
Status/modify	
• Status/modify variable	Yes
• Variables	Inputs, outputs, bit memories, DBs, timers, counters
• Maximum number of variables	30
• Status variables, max.	30

Technical specifications	
• Modify variables, max.	14
Forcing	
• Forcing	Yes
• Variables	Inputs, outputs
• Maximum number of tags	10
Status block	Yes (max. 2 blocks simultaneously)
Single step	Yes
• Number of breakpoints	4
Diagnostic buffer	
• Available	Yes
• No. of entries, max.	500
• Configurable	No
• of which are power-failure-proof	100, only the last 100 entries are retentive
• Maximum number of entries that can be read in RUN	499
• Number of entries that can be set in RUN	Yes (from 10 to 499)
• Number of preset entries in RUN	10
Service data	
• Can be read out	Yes
Monitoring functions	
• Status LEDs	Yes
Communication functions	
PG/OP communication	Yes
Prioritized OCM communication	
• supported	Yes
Routing	
• Number of routing connections	X1 as MPI: max. 10 X1 as DP master: max. 24 X1 as DP slave (active): max. 14 X2 as DP master: max. 24 X2 as DP slave (active): max. 14 X3 as PROFINET: Max. 48
• Data record routing	Yes
Global data communication	
• supported	Yes
• Number of GD circles, max.	8
• Number of GD packets, max.	8
• Number of GD packages, sender, max.	8

Technical specifications	
• Number of GD packets, receiver, max.	8
• Size of GD packets, max.	22 bytes
• Size of GD packets, of those consistent, max.	22 bytes
S7 basic communication	
• supported	Yes
• User data per job, max.	76 bytes
• User data per job, consistent, max.	76 bytes (for X_SEND or X_RCV) 64 bytes (for X_PUT or X_GET as server)
S7 communication	
• supported	Yes
• As server	Yes
• As client	Yes (via integrated PN interface and loadable FBs, or via CP and loadable FBs)
• User data per job, max.	See the STEP 7 Online Help, <i>Common parameters of SFBs/FBs and SFC/FC of the S7 communication</i>
S5-compatible communication	
• supported	Yes (via CP and loadable FCs)
Web server	
• supported	Yes
• Number of HTTP clients	5
• User-defined web pages	Yes
Open IE communication	
• supported	Yes
• Maximum number of connections/access points	32
• Local port number used at the system end	0, 20, 21, 23, 25, 80, 102, 135, 161, 8080, 34962, 34963, 34964, 65532, 65533, 65534, 65535
TCP/IP	
• Maximum number of connections	32
• Data length for connection type 01H, max.	1460 bytes
• Data length for connection type 11H, max.	32768 bytes
• Multiple passive connections per port (multiport), supported	Yes
ISO on TCP	
• Maximum number of connections	32
• Data length, max.	32768 bytes

Technical specifications	
UDP	Yes (via integrated PROFINET interface and loadable FBs)
• Maximum number of connections	32
• Data length, max.	1472 bytes
iPAR server	
• supported	Yes
Number of connections	
• Total	32
Suitable for PG communication	
• PG communication, reserved	1
• PG communication, configurable, min.	1
• PG communication, configurable, max.	31
Suitable for OP communication	
• OP communication, reserved	1
• OP communication, configurable, min.	1
• OP communication, configurable, max.	31
Suitable for S7 basic communication	
• S7 basic communication, reserved	0
• S7 basic communication, configurable, min.	0
• S7 basic communication, configurable, max.	30
Suitable for S7 communication	
• S7 communication, reserved	0
• S7 communication, configurable, min.	0
• S7 communication, configurable, max.	16
Total number of instances, max.	32
PROFINET CBA (with communication load setpoint)	
• Reference setting for the CPU communication load	20 %
• Number of remote interconnecting partners	32
• Number of master/slave functions	50
• Total of all master/slave connections	3000
• Data length of all incoming master/slave connections, max.	24000 bytes
• Data length of all outgoing master/slave connections, max.	24000 bytes

Technical specifications	
• Number of device-internal and PROFIBUS interconnections	1000
• Data length of the device-internal and PROFIBUS interconnections, max.	8000 bytes
• Data length per connection, max.	1400 bytes
Remote interconnections with acyclic transmission	
• Sampling rate: Sampling interval, min.	200 ms
• Number of incoming interconnections	100
• Number of outgoing interconnections	100
• Data length of all incoming interconnections, max.	3200 bytes
• Data length of all outgoing interconnections, max.	3200 bytes
• Data length per connection (acyclic interconnections), max.	1400 bytes
Remote interconnections with cyclic transmission	
• Transmission frequency: Minimum transmission interval	1 ms
• Number of incoming interconnections	300
• Number of outgoing interconnections	300
• Data length of all incoming interconnections, max.	4800 bytes
• Data length of all outgoing interconnections, max.	4800 bytes
• Data length per connection (acyclic interconnections), max.	450 bytes
HMI variables via PROFINET (acyclic)	
• HMI variables update	500 ms
• Number of stations that can be logged on for HMI variables (PN OPC/iMap)	3, (2 x PN OPC/1 x iMap)
• Number of HMI variables	600
• Data length of all HMI variables, max.	9600 bytes
PROFIBUS proxy functionality	
• supported	Yes
• Number of coupled PROFIBUS devices	32
• Data length per connection, max.	240 bytes (slave dependent)

Technical specifications	
Interfaces	
1st interface	
Interface designation	X1
Type of interface	Integrated RS 485 interface
Hardware	RS 485
<ul style="list-style-type: none"> electrically disconnected 	Yes
<ul style="list-style-type: none"> Interface power supply (15 VDC to 30 VDC), max. 	150 mA
Functionality	
<ul style="list-style-type: none"> MPI 	Yes
<ul style="list-style-type: none"> DP master 	Yes
<ul style="list-style-type: none"> DP slave 	Yes
<ul style="list-style-type: none"> Point-to-point connection 	No
<ul style="list-style-type: none"> PROFINET 	No
MPI	
Services	
<ul style="list-style-type: none"> PG/OP communication 	Yes
<ul style="list-style-type: none"> Routing 	Yes
<ul style="list-style-type: none"> Global data communication 	Yes
<ul style="list-style-type: none"> S7 basic communication 	Yes
<ul style="list-style-type: none"> S7 communication 	Yes (server only, connections configured at one end)
<ul style="list-style-type: none"> S7 communication, as client 	No (but via CP and loadable FBs)
<ul style="list-style-type: none"> S7 communication, as server 	Yes
Transmission rate, max.	12 Mbps
DP master	
Services	
<ul style="list-style-type: none"> PG/OP communication 	Yes
<ul style="list-style-type: none"> Routing 	Yes
<ul style="list-style-type: none"> Global data communication 	No
<ul style="list-style-type: none"> S7 basic communication 	Yes (only I blocks)
<ul style="list-style-type: none"> S7 communication 	Yes (server only; connection configured at one end)
<ul style="list-style-type: none"> Constant bus cycle time supported 	Yes
<ul style="list-style-type: none"> Isochronous mode 	No
<ul style="list-style-type: none"> SYNC/FREEZE 	Yes

Technical specifications	
<ul style="list-style-type: none"> • Activate/deactivate DP slaves <ul style="list-style-type: none"> – Max. number of DP slaves that can be enabled / disabled simultaneously 	Yes 8
<ul style="list-style-type: none"> • Direct data exchange (cross-traffic) 	Yes (as subscriber)
<ul style="list-style-type: none"> • DPV1 	Yes
Transmission rate, max.	12 Mbps
Number of DP slaves, max.	124
Address range	
<ul style="list-style-type: none"> • Inputs, max. 	8 KB
<ul style="list-style-type: none"> • Outputs, max. 	8 KB
User data per DP slave	
<ul style="list-style-type: none"> • Inputs, max. 	244 bytes
<ul style="list-style-type: none"> • Outputs, max. 	244 bytes
DP slave (DP slave at both DP interfaces is excluded)	
Services	
<ul style="list-style-type: none"> • PG/OP communication 	Yes
<ul style="list-style-type: none"> • Routing 	Yes (only if interface is active)
<ul style="list-style-type: none"> • Global data communication 	No
<ul style="list-style-type: none"> • S7 basic communication 	No
<ul style="list-style-type: none"> • S7 communication 	Yes (server only; connection configured at one end)
<ul style="list-style-type: none"> • Direct data exchange (cross-traffic) 	Yes
<ul style="list-style-type: none"> • DPV1 	No
Transmission rate, max.	12 Mbps
Automatic baud rate detection	Yes (only if interface is passive)
Transfer memory	
<ul style="list-style-type: none"> • Inputs 	244 bytes
<ul style="list-style-type: none"> • Outputs 	244 bytes
<ul style="list-style-type: none"> • Address range, max. 	32
<ul style="list-style-type: none"> • User data per address range, max. 	32 bytes
GSD file	The current GSD file is available for download from the Internet (http://www.siemens.com/profibus-gsd).
2nd interface	
Interface designation	X2
Type of interface	Integrated RS 485 interface
Hardware	RS 485
<ul style="list-style-type: none"> • electrically disconnected 	Yes

Technical specifications	
• Interface power supply (15 VDC to 30 VDC), max.	200 mA
Functionality	
• MPI	No
• DP master	Yes
• DP slave	Yes
• PROFINET IO controller	No
• PROFINET IO device	No
• PROFINET CBA	No
• Open IE communication	No
• Web server	No
DP master	
Services	
• PG/OP communication	Yes
• Routing	Yes
• Global data communication	No
• S7 basic communication	Yes (intelligent blocks only)
• S7 communication	Yes (server only; connection configured at one end)
• S7 communication, as client	No
• S7 communication, as server	Yes
• Constant bus cycle time supported	Yes
• Isochronous mode	Yes (OB 61 - operation in isochronous mode is possible either on DP, or on PROFINET IO (not concurrently))
• SYNC/FREEZE	Yes
• Activate/deactivate DP slaves – Max. number of DP slaves that can be enabled / disabled simultaneously	Yes 8
• Direct data exchange (cross-traffic)	Yes (as subscriber)
• DPV1	Yes
Transmission rate, max.	12 Mbps
Number of DP slaves	124
Address range	
• Inputs, max.	8 KB
• Outputs, max.	8 KB
User data per DP slave	

Technical specifications	
• Inputs, max.	244 bytes
• Outputs, max.	244 bytes
DP slave (DP slave at both DP interfaces is excluded)	
Services	
• PG/OP communication	Yes
• Routing	Yes (only if interface is active)
• Global data communication	No
• S7 basic communication	No
• S7 communication	Yes (server only; connection configured at one end)
• S7 communication, as client	No
• S7 communication, as server	Yes
• Direct data exchange (cross-traffic)	Yes
• DPV1	No
Transmission rate, max.	12 Mbps
Automatic baud rate detection	Yes (only if interface is passive)
GSD file	The current GSD file is available for download from the Internet (http://www.siemens.com/profibus-gsd).
Transfer memory	
• Inputs	244 bytes
• Outputs	244 bytes
• Address areas, max.	32
• User data per address range, max.	32 bytes
3rd interface	
Interface designation	X3
Type of interface	PROFINET
Hardware	RJ45 Ethernet
• electrically disconnected	Yes
• Integrated switch	Yes
• Number of ports	2
• Automatic determination of the transmission rate	Yes (10/100 Mbps)
• Autonegotiation	Yes
• Autocrossing	Yes
Media redundancy	
• supported	Yes

Technical specifications	
• Changeover time on line break, typically	200 ms (PROFINET MRP)
• Number of nodes on the ring, max.	50
Change of the IP address at runtime, supported	Yes
Keep-alive function, supported	Yes
Functionality	
• MPI	No
• DP master	No
• DP slave	No
• PROFINET IO controller	Yes, even simultaneously with IO device functionality
• PROFINET IO device	Yes, even simultaneously with IO controller functionality
• PROFINET CBA	Yes (acyclic and cyclic transmission)
• Open IE communication	Yes; via TCP/IP, ISO on TCP, UDP
• Web server	Yes
– Number of HTTP clients	5
PROFINET IO controller	
Services	
• PG/OP communication	Yes
• Routing	Yes
• S7 communication	Yes (with loadable FBs, max. configurable connections: 16; maximum number of instances: 32)
• Open IE communication	Yes; via TCP/IP, ISO on TCP, UDP
Number of integrated IO controllers	1
RT, supported	Yes
IRT, supported	Yes
Transmission rate, max.	100 Mbps
Maximum number of connectable IO devices	256
Number of connectable IO devices, for RT, max.	256
• of which in line, max.	256
Number of IO devices with IRT and "high flexibility" option	256
• of which in line, max.	61
Number of IO devices with IRT and "high performance" option, max.	64
• of which in line, max.	64
Shared Device, supported	Yes

Technical specifications	
Isochronous mode	Yes (OB 61 - operation in isochronous mode is possible either on DP, or on PROFINET IO (not concurrently))
Prioritized startup, supported	Yes
<ul style="list-style-type: none"> Maximum number of IO devices with prioritized startup 	32
Activating/deactivating of PROFINET IO Devices	Yes
<ul style="list-style-type: none"> Number of IO devices that can be enabled / disabled simultaneously, max. 	8
IO devices changing during runtime (partner ports), supported	Yes
<ul style="list-style-type: none"> Number of IO devices per tool, max. 	8
Device replacement without removable medium	Yes
Send clocks	250 μ s, 500 μ s, 1 ms 2 ms, 4 ms (not for IRT with "high flexibility" option)
Update time	
<ul style="list-style-type: none"> Update times 	The minimum update time also depends on the time slice set for PROFINET IO communication, the number of IO Devices used, and on the amount of configured user data.
With RT	
<ul style="list-style-type: none"> for send clock of 250 μs 	250 μ s to 128 ms
<ul style="list-style-type: none"> for send clock of 500 μs 	500 μ s to 256 ms
<ul style="list-style-type: none"> for send clock of 1 ms 	1 ms to 512 ms
<ul style="list-style-type: none"> for send clock of 2 ms 	2 ms to 512 ms
<ul style="list-style-type: none"> for send clock of 4 ms 	4 ms to 512 ms
For IRT with "high flexibility" option	
<ul style="list-style-type: none"> for send clock of 250 μs 	250 μ s to 128 ms
<ul style="list-style-type: none"> for send clock of 500 μs 	500 μ s to 256 ms
<ul style="list-style-type: none"> for send clock of 1 ms 	1 ms to 512 ms
For IRT with "high performance" option	
<ul style="list-style-type: none"> for send clock of 250 μs 	250 μ s to 4 ms
<ul style="list-style-type: none"> for send clock of 500 μs 	500 μ s to 8 ms
<ul style="list-style-type: none"> for send clock of 1 ms 	1 ms to 16 ms
<ul style="list-style-type: none"> for send clock of 2 ms 	2 ms to 32 ms
<ul style="list-style-type: none"> for send clock of 4 ms 	4 ms to 64 ms
For IRT with "high performance" option and parameter assignment for "odd-numbered" send clocks	Update time = "odd-numbered" send clock set (any multiple of 125 μ s: 375 μ s, 625 μ s to 3.875 ms)

Technical specifications	
Address range	
• Inputs, max.	8192 bytes
• Outputs, max.	8192 bytes
User data per address range, max.	
• User data consistency, max.	1024 bytes
PROFINET IO device	
Services	
• PG/OP communication	Yes
• Routing	Yes
• S7 communication	Yes (with loadable FBs, max. configurable connections: 16, maximum number of instances: 32)
• Open IE communication	Yes; via TCP/IP, ISO on TCP, UDP
RT, supported	Yes
IRT, supported	Yes
PROFenergy, supported	<i>Prepared with SFB 73 / 74 for loadable PROFenergy standard FBs for intelligent IO devices</i>
Shared Device, supported	Yes
• Number of IO controllers for shared devices, max.	2
Isochronous mode	No
Application transfer areas	Yes
IO devices transfer area	No
Transfer memory	
• Inputs, max.	1440 bytes; per controller for shared devices
• Outputs, max.	1440 bytes; per controller for shared devices
Submodules	
• Number, max.	64
• User data per submodule, max.	1024 bytes
Programming	
Programming language	
• LAD	Yes
• FBD	Yes
• STL	Yes
• SCL	Yes
• CFC	Yes
• GRAPH	Yes

Technical specifications	
• HiGraph®	Yes
Instruction set	See instruction list
• Nesting levels	8
Know-how protection	
• User program protection / password protection	Yes
• Encryption of blocks	Yes, using S7-Block Privacy
System functions (SFC)	See instruction list
System function blocks (SFB)	See instruction list
Dimensions	
• Mounting dimensions W x H x D (mm)	120 x 125 x 130
• Weight	1250 g
Voltages and currents	
• Power supply (rated value)	24 VDC
• Low limit of admissible range (DC)	19.2 V
• High limit of admissible range (DC)	28.8 V
• Current consumption (open-circuit), typically	500 mA
• Inrush current, typ.	4 A
• Current consumption (rated value)	1250 mA
• I ² t	1.2 A ² s
• External protection of power supply lines, min.	2 A
• Power loss, typically	14 W

ماكان كنترول

Glossary

Accumulator

Accumulators represent CPU register and are used as buffer memory for download, transfer, comparison, calculation and conversion operations.

Address

An address is the identifier of a specific address or address area. Examples: Input I 12.1; Flag Word MW 25; Data Block DB 3.

Analog module

Analog modules convert process values (e.g. temperature) into digital values which can be processed in the CPU, or they convert digital values into analog manipulated variables.

Application

An application is a program that runs directly on the MS-DOS / Windows operating system. Applications on the programming device are for example STEP 7.

ASIC

ASIC is the acronym for Application Specific Integrated Circuits.

PROFINET ASICs are components with a wide range of functions for the development of your own devices. They implement the requirements of the PROFINET standard in a circuit and allow extremely high packing densities and performance.

Because PROFINET is an open standard, SIMATIC NET offers PROFINET ASICs for the development of your old devices under the name ERTEC .

Backplane bus

The backplane bus is a serial data bus. It supplies power to the modules and is also used by the modules to communicate with each other. Bus connectors interconnect the modules.

Backup memory

Backup memory ensures buffering of the memory areas of a CPU without backup battery. It backs up a configurable number of timers, counters, memory and data bytes,retentive timers, counters, memory bits and data bytes.

Bit memory

Bit memories are part of the CPU's system memory. They store intermediate results of calculations. They can be accessed in bit, word or dword operations.

See System memory

Bus

A bus is a communication medium connecting several nodes. Data can be transferred via serial or parallel circuits, that is, via electrical conductors or fiber optic.

Bus segment

A bus segment is a self-contained section of a serial bus system. Bus segments are interconnected by way of repeaters, for example, in PROFIBUS DP.

Central module

→ CPU

Changing IO devices during operation (changing partner ports)

Functionality of a PROFINET device.

A PROFINET device that supports this function can communicate during operation with changing communication partners at the same port.

Clock memory

flag bit which can be used to generate clock pulses in the user program (1 byte per flag bit).

Note

When operating with S7-300 CPUs, make sure that the byte of the clock memory bit is not overwritten in the user program!

Coaxial cable

A coaxial cable, also known as "coax", is a metal conductor system used in HF transmission circuits, for example, as radio and TV antenna cable, and in modern networks demanding high data transmission rates. The inner conductor of a coaxial cable is sheathed by a tube-like outer conductor. These conductors are separated by plastic insulation. In contrast to other cables, this type of cable provides a high degree of immunity to interference and EMC compatibility.

Code block

A SIMATIC S7 code block contains part of the **STEP 7** user program. (in contrast to a DB: this contains only data.)

Communication processor

Communication processors are modules used for point-to-point and bus topologies.

Component Based Automation

→ *PROFINET CBA*

Compress

The PG online function "Compress" is used to rearrange all valid blocks in CPU RAM in a contiguous area of load memory, starting at the lowest address. This eliminates fragmentation which occurs when blocks are deleted or edited.

Configuration

Assignment of modules to module racks/slots and (e.g. for signal modules) addresses.

Consistent data

Data which belongs together in terms of content and must not be separated is known as consistent data.

For example, the values of analog modules must always be handled as a whole, that is, the value of an analog module must not be corrupted as a result of read access at two different points of time.

Counters

Counters are part of CPU system memory. The content of "Counter cells" can be modified by **STEP 7** instructions (for example, up/down count.)

See also System memory

CP

→ *Communication processor*

CPU

Central processing unit = CPU of the S7 automation system with a control and arithmetic unit, memory, operating system, and interface for programming device.

Cycle control point

The cycle control point is the section of the CPU program processing in which the process image is updated.

Cycle time

The cycle time represents the time a CPU requires for one execution of the user program.

Cyclic interrupt

→ *Interrupt, cyclic interrupt*

Data block

Data blocks (DB) are data areas in the user program which contain user data. There are global data blocks which can be accessed by all code blocks, and instance data blocks which are assigned to a specific FB call.

Data exchange broadcast

→ *Direct data exchange*

Data exchange traffic

→ *Direct data exchange*

Data set routing

Functionality of a module with several network connections. Modules that support this function are able to pass on data of an engineering system (for example parameter data generated by SIMATIC PDM) from a subnetwork such as Ethernet to a field device at the PROFIBUS DP.

Data, static

Static data can only be used within a function block. These data are saved in an instance data block that belongs to a function block. Data stored in an instance data block are retained until the next function block call.

Data, temporary

Temporary data represent local data of a block. They are stored in the L-stack when the block is executed. After the block has been processed, these data are no longer available.

DB

→ *Data block*

DCP

DCP (Discovery and Basic Configuration Protocol). Enables the assignment of device parameters (e.g. the IP address) using manufacturer-specific configuration/programming tools.

Default router

The default router is the router that is used when data must be forwarded to a partner located within the same subnet.

In STEP 7, the default router is named *Router*. STEP 7 assigns the local IP address to the default router.

Detecting the network topology

LLDP (Link Layer Discovery Protocol) is a protocol that is used to detect the closest neighbors. It enables a device to send information about itself and to save information received from neighboring devices in the LLDP MIB. This information can be looked up via the SNMP. This information allows a network management system to determine the network topology.

Determinism

→ *Real Time*

Device

Within the context of PROFINET, "device" is the generic term for:

- Automation systems,
- Field devices (e.g. PLC, PC)
- Active network components (for example, distributed I/O, valve blocks, drives),
- hydraulic devices and
- pneumatic devices.

The main characteristic of a device is its integration in PROFINET communication over Ethernet or PROFIBUS.

The following device types are distinguished based on their attachment to the bus:

- PROFINET devices
- PROFIBUS devices

Device Name

Before an IO device can be addressed by an IO controller, it must have a device name. In PROFINET, this method was selected because it is simpler to work with names than with complex IP addresses.

The assignment of a device name for a concrete IO device can be compared with setting the PROFIBUS address of a DP slave.

When it ships, an IO device does not have a device name. An IO device can only be addressed by an IO controller, for example for the transfer of project engineering data (including the IP address) during startup or for user data exchange in cyclic operation, after it has been assigned a device name with the PG/PC .

Device replacement without removable medium/programming device

It is easy to replace IO devices that support this function:

- A removable medium (such as a SIMATIC Micro Memory Card) with stored device name is not required.
- The device name does not have to be assigned with the programming device.
- A replaced IO device that has already been put into operation must be reset to factory settings using the "Reset to factory settings" function.

The replaced IO device is assigned the device name by the IO controller and no longer from a removable media or programming device. The IO controller uses the configured topology and the neighboring relationships determined by the IO devices to this purpose. The configured target topology must coincide accordingly with the actual topology.

Diagnostic buffer

The diagnostics buffer represents a buffered memory area in the CPU. It stores diagnostic events in the order of their occurrence.

Diagnostic interrupt

Modules capable of diagnostics operations report detected system errors to the CPU by means of diagnostic interrupts.

Diagnostics

→ *System diagnostics*

Direct data exchange

Direct data exchange is a special communication relationship between PROFIBUS DP nodes. Direct data exchange is characterized by PROFIBUS DP nodes that "listen" on the bus and know which data a DP slave returns to its DP master.

DP master

A master which behaves in accordance with EN 50170, Part 3 is known as a DP master.

DP slave

A slave operated on PROFIBUS with PROFIBUS DP protocol and in accordance with EN 50170, Part 3 is referred to as DP slave.

DPV1

The designation DPV1 means extension of the functionality of the acyclical services (to include new interrupts, for example) provided by the DP protocol. The DPV1 functionality has been incorporated into IEC 61158/EN 50170, volume 2, PROFIBUS.

Electrically isolated

The reference potentials of the control and load circuit of isolated I/O modules are electrically isolated, for example, by means of optocouplers, relays or transformers. Input/output circuits may be grouped.

Equipotential bonding

Electrical connection (equipotential bonding conductor) which eliminates potential difference between electrical equipment and external conductive bodies by drawing potential to the same or near the same level, in order to prevent disturbing or dangerous voltages between these bodies.

Error display

One of the possible reactions of the operating system to a runtime error is to output an error message. Additional reactions: Error reaction in the user program, CPU in STOP.

Error handling via OB

After the operating system has detected a specific error (e.g. access error with **STEP 7**), it calls a dedicated block (Error OB) that determines additional CPU actions.

Error response

Reaction to a runtime error. Reactions of the operating system: It sets the automation system to STOP, indicates the error, or calls an OB in which the user can program a reaction.

ERTEC

→ *ASIC*

Fast Ethernet

Fast Ethernet describes the standard with which data is transmitted at 100 Mbps. Fast Ethernet uses the 100 Base-T standard.

FB

→ *Function block*

FC

→ *Function*

FEPROM

→ *Memory Card (MC)*

Flash EPROM

FEPROMs can retain data in the event of power loss, same as electrically erasable EEPROMs. However, they can be erased within a considerably shorter time (FEPROM = Flash Erasable Programmable Read Only Memory). They are used on Memory Cards.

Force

The Force function can be used to assign the variables of a user program or CPU (also: inputs and outputs) constant values.

In this context, please note the limitations listed in the *Overview of the test functions section in the chapter entitled Test functions, Diagnostics and Troubleshooting in the S7-300 Installation manual.*

Function

According to IEC 1131-3, a function (FC) is a code block without static data. A function allows parameters to be passed in the user program. Functions are therefore suitable for programming frequently occurring complex functions, e.g. calculations.

Function block

According to IEC 1131-3, a function block (FB) is a code block with static data. A function block allows parameters to be transferred to the user program. Function blocks are therefore suitable for programming frequently recurring, complex functions, e.g., rules, mode selection.

Functional ground

Grounding which has the sole purpose of safeguarding the intended function of electrical equipment. With functional grounding you short-circuit interference voltage which would otherwise have an unacceptable impact on equipment.

GD circuit

A GD circuit comprises a number of CPUs sharing data by means of global data communication, and is used as follows:

- A CPU broadcasts a GD packet to the other CPUs.
- A CPU sends and receives a GD packet from another CPU.

A GD circuit is identified by a GD circuit number.

GD element

A GD element is generated by assigning shared global data. It is identified by a unique global data ID in the global data table.

GD packet

A GD packet can consist of one or several GD elements transmitted in a single message frame.

Global data

Global data can be addressed from any code block (FC, FB, OB). In particular, this refers to bit memories M, inputs I, outputs Q, timers, counters and data blocks DB. Global data can be accessed via absolute or symbolic addressing.

Global data communication

Global data communication is a procedure that is used to transfer global data between CPUs (without SFCs/SFBs).

Ground

The conductive earth whose electrical potential can be set equal to zero at any point.

Ground potential can be different from zero in the area of grounding electrodes. The term reference ground is frequently used to describe this situation.

Grounding means, to connect an electrically conductive component via an equipotential grounding system to a grounding electrode (one or more conductive components with highly conductive contact to earth).

Chassis ground is the totality of all the interconnected passive parts of a piece of equipment on which dangerous fault-voltage cannot occur.

Ground

The conductive earth whose electrical potential can be set equal to zero at any point.

Ground potential can be different from zero in the area of grounding electrodes. The term reference ground is frequently used to describe this situation.

Grounding means, to connect an electrically conductive component via an equipotential grounding system to a grounding electrode (one or more conductive components with highly conductive contact to earth).

Chassis ground is the totality of all the interconnected passive parts of a piece of equipment on which dangerous fault-voltage cannot occur.

GSD file

The properties of a PROFINET device are described in a GSD file (General Station Description) that contains all the information required for configuration.

As with PROFIBUS, you can link a PROFINET device in STEP 7 by means of a GSD file.

In PROFINET IO, the GSD file is in XML format. The structure of the GSD file conforms to ISO 15734, which is the world-wide standard for device descriptions.

In PROFIBUS, the GSD file is in ASCII format.

Hardware interrupt

A hardware interrupt is triggered by interrupt-triggering modules as a result of a specific event in the process. The hardware interrupt is reported to the CPU. The assigned organization block will be processed according to interrupt priority.

HART

English: **H**ighway **A**ddressable **R**emote **T**ransducer

I-Device

The "I-Device" (intelligent IO device) functionality of a CPU facilitates data exchange with an IO controller and operation of the CPU, for example, as intelligent preprocessing unit of sub processes. Accordingly, the intelligent device is integrated into a "higher-level" IO controller, acting as IO device.

The functionality of the intelligent device ensures that the data is pre-processed in the user program on the CPU. The process values acquired from central or distributed locations (PROFINET IO or PROFIBUS DP) are pre-processed in the user program and provided to a higher-level station via PROFINET IO device interface of the CPU.

Industrial Ethernet

Industrial Ethernet (formerly SINEC H1) is a technology that allows data to be transmitted free of interference in an industrial environment.

Due to the openness of PROFINET, you can use standard Ethernet components. We recommend, however, that you install PROFINET as Industrial Ethernet.

Instance data block

The **STEP 7** user program assigns an automatically generated DB to every call of a function block. The instance data block stores the values of input, output and in/out parameters, as well as local block data.

Interface, MPI-compatible

→ *MPI*

Interrupt

The CPU's operating system distinguishes between different priority classes for user program execution. These priority classes include interrupts, e.g. process interrupts. When an interrupt is triggered, the operating system automatically calls an assigned OB. In this OB the user can program the desired response (e.g. in an FB).

Interrupt, cyclic interrupt

A cyclic interrupt is generated periodically by the CPU in a configurable time pattern. A corresponding OB will be processed.

Interrupt, diagnostic

→ *Diagnostic interrupt*

Interrupt, hardware

→ *Hardware interrupt*

Interrupt, status

A status interrupt can be generated by a DPV1 slave or a PNIO device respectively. At the DPV1 master or the PNIO controller respectively the receipt of the interrupt causes the OB 55 to be called up.

For detailed information on OB 56, refer to the *Reference Manual System Software for S7-300/400: System and Standard Functions*.

Interrupt, time-delay

The delay interrupt belongs to one of the priority classes in SIMATIC S7 program processing. It is generated on expiration of a time started in the user program. A corresponding OB will be processed.

Interrupt, time-delay

→ *Interrupt, time-delay*

Interrupt, time-of-day

The time-of-day interrupt belongs to one of the priority classes in SIMATIC S7 program processing. It is generated at a specific date (or daily) and time-of-day (e.g. 9:50 or hourly, or every minute). A corresponding OB will be processed.

Interrupt, update

An update interrupt can be generated by a DPV1 slave or a PNIO device respectively. At the DPV1 master or the PNIO controller respectively the receipt of the interrupt causes the OB 56 to be called up.

For detailed information on OB 56, refer to the *Reference Manual System Software for S7-300/400: System and Standard Functions*.

Interrupt, vendor-specific

A vendor-specific interrupt can be generated by a DPV1 slave or a PNIO device respectively. At the DPV1 master or the PNIO controller respectively, receipt of the interrupt causes the OB 57 to be called.

For detailed information on OB 57, refer to the *Reference Manual System Software for S7-300/400: System and Standard Functions*.

IP address

To allow a PROFINET device to be addressed as a node on Industrial Ethernet, this device also requires an IP address that is unique within the network. The IP address is made up of 4 decimal numbers with a range of values from 0 through 255. The decimal numbers are separated by a period.

The IP address is made up of

- The address of the (subnet) network and
- The address of the node (generally called the host or network node).

IRT

→ *Isochronous Real Time communications*

Isochronous mode

In order to maximize deterministic performance, the process data, the transmission cycle via PROFIBUS DP or PROFINET IO, as well as the user program are synchronized. The input and output data of the distributed IO devices in the system is acquired and output simultaneously. The isochronous PROFIBUS DP cycle/PROFINET IO cycle acts as the corresponding clock generator.

Isochronous Real Time communications

Synchronized transmission procedure for the cyclic exchange of IO data between PROFINET devices.

A reserved bandwidth within the send clock is available for the IRT / IO data. The reserved bandwidth guarantees that the IRT data can also be transferred even during another high network load (for example TCP/IP communication or additional real time communication) at reserved, synchronized intervals.

LAN

Local Area Network; interconnects multiple computers within a company. The geographical topology of a LAN is limited to the local premises and is only available to the operating company or institution.

LLDP

LLDP (Link Layer Discovery Protocol) is a protocol that is used to detect the closest neighbors. It enables a device to send information about itself and to save information received from neighboring devices in the LLDP MIB. This information can be looked up via the SNMP. This information allows a network management system to determine the network topology.

Load memory

This memory contains objects generated by the programming device. Load memory is implemented by means of a plug-in Micro Memory Card of different memory capacities. The SIMATIC Micro Memory Card must be inserted to allow CPU operation.

Load power supply

Power supply to the signal / function modules and the process I/O connected to them.

Local data

→ *Data, temporary*

MAC address

Each PROFINET device is assigned a worldwide unique device identifier in the factory. This 6-byte long device identifier is the MAC address.

The MAC address is divided up as follows:

- 3 bytes vendor identifier and
- 3 bytes device identifier (consecutive number).

The MAC address is normally printed on the front of the device.

Example: 08-00-06-6B-80-C0

Main memory

The main memory is integrated in the CPU and cannot be extended. It is used to run the code and process user program data. Programs only run in the main memory and system memory.

Master

When a master has the token, it can send data to other nodes and request data from other nodes (= active node).

Media redundancy

Function that ensures network and system availability. Redundant transmission links (ring topology) ensure that an alternative communication path is made available if a transmission link fails.

Memory Card (MC)

Memory Cards are memory media for CPUs and CPs. They are implemented in the form of RAM or FEPRAM. An MC differs from a Micro Memory Card only in its dimensions (MC is approximately the size of a credit card).

Micro Memory Card (MMC)

Micro Memory Cards are memory media for CPUs and CPs. Their only difference to the Memory Card is the smaller size.

Module parameters

Module parameters are values which can be used to configure module behavior. A distinction is made between static and dynamic module parameters.

MPI

The multipoint interface (MPI) represents the programming device interface of SIMATIC S7. It enables multiple nodes (PGs, text-based displays, OPs) to be operated simultaneously by one or more CPUs. Each node is identified by its unique (MPI) address.

MPI address

→ *MPI*

NCM PC

→ *SIMATIC NCM PC*

Nesting depth

A block can be called from another by means of a block call. Nesting depth is referred to as the number of simultaneously called code blocks.

Network

A network consists of one or more interconnected subnets with any number of nodes. Several networks can exist alongside each other.

Network

A network is a larger communication system that allows data exchange between a large number of nodes.

All the subnets together form a network.

Non-isolated

The reference potential of the control and on-load power circuits of non-isolated I/O modules is electrically interconnected.

NTP

The Network Time Protocol (NTP) is a standard for synchronizing clocks in automation systems via Industrial Ethernet. NTP uses the UDP wireless network protocol.

OB

→ *Organization blocks*

OB priority

The CPU operating system distinguishes between different priority classes, for example, cyclic program processing, hardware interrupt controlled program processing. Each priority class is assigned organization blocks (OBs) in which the S7 user can program a response. The OBs are assigned different default priority classes. These determine the order in which OBs are executed or interrupt each other when they appear simultaneously.

Operating state

SIMATIC S7 automation systems know the following operating states: STOP, START, RUN.

Operating system

The CPU operating system organizes all the CPU functions and processes which are not associated with a specific control task.

Organization blocks

Organization blocks (OBs) form the interface between the CPU operating system and the user program. The order in which the user program is executed is defined in the organization blocks.

Parameters

1. Variable of a **STEP 7** code block
2. Variable for declaring module response (one or several per module). All modules have a suitable basic factory setting which can be customized in **STEP 7**. There are static and dynamic parameters.

Parameters, dynamic

Unlike static parameters, you can change dynamic module parameters during runtime by calling an SFC in the user program, e.g. limit values of an analog signal input module.

Parameters, static

Unlike dynamic parameters, static parameters of modules cannot be changed by the user program. You can only modify these parameters by editing your configuration in **STEP 7**, for example, modification of the input delay parameters of a digital signal input module.

PC station

→ *SIMATIC PC station*

PG

→ *Programming device*

PLC

→ *Programmable logic controller*

PLC

A PLC in the context of SIMATIC S7 --> is a programmable logic controller.

PNO

Technical committee that defines and additional develops the PROFIBUS and PROFINET standards with the following homepage: <http://www.profinet.com>.

Prioritized startup

The term prioritized startup denotes the PROFINET functionality for accelerating the startup of IO devices operated on a PROFINET IO system with RT and IRT communication.

The function reduces the time that configured IO devices require in order to return to cyclic user data exchange in the following scenarios:

- After the power supply has returned
- After a station has come back online
- After the activation of IO devices

Priority class

The S7 CPU operating system provides up to 26 priority classes (or "Program execution levels"). Specific OBs are assigned to these classes. The priority classes determine which OBs interrupt other OBs. Multiple OBs of the same priority class do not interrupt each other. In this case, they are executed sequentially.

Process image

The process image is part of CPU system memory. At the start of cyclic program execution, the signal states at the input modules are written to the process image of the inputs. At the end of cyclic program execution, the signal status of the process image of the outputs is transferred to the output modules.

Process-Related Function

→ *PROFINET components*

Product version

The product version identifies differences between products which have the same order number. The product version is incremented when forward-compatible functions are enhanced, after production-related modifications (use of new parts/components) and for bug fixes.

PROFIBUS

Process Field Bus - European field bus standard.

PROFIBUS device

A PROFIBUS device has at least one PROFIBUS connection to an electric interface (RS485), or to an optoelectronic interface (polymer optical fiber, POF).

A PROFIBUS device cannot take part directly in PROFINET communication but must be included over a PROFIBUS master with a PROFINET port or an Industrial Ethernet/PROFIBUS link (IE/PB Link) with proxy functionality.

PROFIBUS DP

A PROFIBUS with the DP protocol that complies with EN 50170. DP stands for distributed peripheral (IO) = fast, real-time, cyclic data exchange. From the perspective of the user program, the distributed IOs are addressed in exactly the same way as the central IOs.

PROFINET

Within the framework of Totally Integrated Automation (TIA), PROFINET represents a consistent continuation of:

- PROFIBUS DP, the established fieldbus and
- Industrial Ethernet, the communication bus for the cell level

Experience gained from both systems was and is being integrated into PROFINET.

PROFINET is an Ethernet-based automation standard of PROFIBUS International (previously PROFIBUS user organization) and defines a multi-vendor communication, automation, and engineering model.

PROFINET ASIC

→ ASIC

ماكان كنترول

PROFINET CBA

Within the PROFINET system, PROFINET CBA (Component Based Automation) is an automation concept that focuses on the following:

- Implementation of modular applications
- Machine to machine communication

PROFINET CBA lets you create distributed automation solutions based on ready-to-use components and partial solutions. This concept meets demands for a higher degree of modularity in the field of mechanical and systems engineering through extensive distribution of intelligent processes.

Component Based Automation allows you to implement complete technological modules form operation as standardized components in large-scale systems.

You create the modular, intelligent components of PROFINET CBA using an engineering tool that could differ depending on the device manufacturer. Components that consist of SIMATIC devices are created in STEP 7 and interconnected using the SIMATIC IMAP tool.

PROFINET components

A PROFINET component includes the entire data of the hardware configuration, the parameters of the modules, and the corresponding user program. The PROFINET component is made up as follows:

- Technological Function

The (optional) technological (software) function includes the interface to other PROFINET components in the form of interconnectable inputs and outputs.

- Device

The device is the representation of the physical programmable controller or field device including the I/O, sensors and actuators, mechanical parts, and the device firmware.

PROFINET device

A PROFINET device always has at least one Industrial Ethernet port. PROFINET devices also support optional operation as proxy acting as representative that safeguards Ethernet communication between PROFIBUS devices (PROFIBUS-Slaves) connected to a PROFIBUS interface and additional PROFINET devices on the Ethernet.

PROFINET IO

Within the framework of PROFINET, PROFINET IO is a communication concept for the implementation of modular, distributed applications.

PROFINET IO allows you to create automation solutions which are familiar to you from PROFIBUS.

PROFINET IO is implemented based on the PROFINET standard for programmable controllers.

The STEP 7 engineering tool supports engineering and configuring of an automation solution.

STEP 7 therefore provides the same application view, regardless of whether you are configuring PROFINET or PROFIBUS devices. Generally speaking, the programs for your PROFINET IO and PROFIBUS DP applications are identical, however, for PROFINET IO you must use the extended SFCs/SFBs and system status lists.

PROFINET IO controller

Device used to address the connected IO devices. This means that the IO controller exchanges input and output signals with assigned field devices. The IO controller is often the controller on which the automation program runs.

PROFINET IO device

A distributed field device that is assigned to one of the IO controllers (e.g. remote IO, valve terminals, frequency converters, switches)

PROFINET IO Supervisor

Programming device, PC or HMI device used for commissioning and diagnostics.

PROFINET IO system

PROFINET IO controller with assigned PROFINET IO devices.

Programmable logic controller

Programmable controllers (PLCs) are electronic controllers whose function is stored as a program in the control unit. The structure and wiring of the device does not therefore depend on the controller's function. A programmable logic controller is structured like a computer. It consists of a CPU with memory, input/output modules and an internal bus system. The IOs and the programming language are oriented to control engineering needs.

Programming device

Programming devices are essentially compact and portable PCs which are suitable for industrial applications. They are identified by a special hardware and software for programmable logic controllers.

Proxy

The PROFINET device with proxy functionality is the substitute for a PROFIBUS device on Ethernet. The proxy functionality allows a PROFIBUS device to communicate not only with its master but also with all nodes on PROFINET.

You can integrate existing PROFIBUS systems into PROFINET communication, for example with the help of an IE/PB Link or a CPU 31x PN/DP. The IE/PB Link then handles communication over PROFINET as a substitute for the PROFIBUS components.

RAM

RAM (Random Access Memory) is a semiconductor read/write memory.

Real Time

Real time means that a system processes external events within a defined time.

Determinism means that a system reacts in a predictable (deterministic) manner.

In industrial networks, both these requirements are important. PROFINET meets these requirements. PROFINET is implemented as a deterministic real-time network as follows:

- The transfer of time-critical data between different stations over a network within a defined interval is guaranteed.

To achieve this, PROFINET provides an optimized communication channel for real-time communication : Real Time (RT).

- An exact prediction of the time at which the data transfer takes place is possible.
- It is ensured that problem-free communication using other standard protocols, for example industrial communication for PG/PC can take place within the same network.

Real Time

→ *Real Time*

Reduction ratio

The reduction rate determines the send/receive frequency for GD packets on the basis of the CPU cycle.

Reference ground

→ *Ground*

Reference potential

Voltages of participating circuits are referenced to this potential when they are viewed and/or measured.

Restart

On CPU start-up (e.g. after is switched from STOP to RUN mode via selector switch or with POWER ON), OB100 (restart) is initially executed, prior to cyclic program execution (OB1). On restart, the input process image is read in and the **STEP 7** user program is executed, starting at the first instruction in OB1.

Retentivity

A memory area is considered retentive if its contents are retained even after a power loss and transitions from STOP to RUN. The non-retentive area of memory flag bits, timers and counters is reset following a power failure and a transition from the STOP mode to the RUN mode.

Retentive can be the:

- Bit memory
- S7 timers
- S7 counters
- Data areas

Router

A router interconnects two subnets. A router works in a similar way to a switch. With a router, however, you can also specify which communication nodes may communicate via the router and which may not. The communication nodes on various sides of a router can only communicate with one another if you have explicitly enabled communication between these nodes via the router. Real-time data cannot be exchanged beyond subnet boundaries.

RT

→ *Real Time*

Runtime error

Errors occurred in the PLC (that is, not in the process itself) during user program execution.

Segment

→ *Bus segment*

SFB

→ *System function block*

SFC

→ *System function*

Shared Device

The "Shared Device" functionality makes it possible to distribute the submodules of an IO devices to different IO controllers.

Signal module

Signal modules (SM) form the interface between the process and the PLC. There are digital input and output modules (input/output module, digital) and analog input and output modules. (Input/output module, analog)

SIMATIC

The term denotes Siemens AG products and systems for industrial automation.

SIMATIC NCM PC

SIMATIC NCM PC is a version of STEP 7 tailored to PC configuration. For PC stations, it offers the full range of functions of STEP 7.

SIMATIC NCM PC is the central tool with which you configure the communication services for your PC station. The configuration data generated with this tool must be downloaded to the PC station or exported. This makes the PC station ready for communication.

SIMATIC NET

Siemens Industrial Communication division for Networks and Network Components.

SIMATIC PC station

A "PC station" is a PC with communication modules and software components within a SIMATIC automation solution.

Slave

A slave can only exchange data after being requested to do so by the master.

SNMP

SNMP (Simple Network Management Protocol) makes use of the wireless UDP transport protocol. It consists of two network components, similar to the client/server model. The SNMP Manager monitors the network nodes, and the SNMP agents collect the various network-specific information in the individual network nodes and places it in a structured form in the MIB (Management Information Base). This information allows a network management system to run detailed network diagnostics.

SSL

→ *System status list*

STARTUP

A START-UP routine is executed at the transition from STOP to RUN mode. Can be triggered by means of the mode selector switch, or after power on, or by an operator action on the programming device. An S7-300 performs a restart.

STEP 7

STEP 7 is an engineering system and contains programming software for the creation of user programs for SIMATIC S7 controllers.

Subnet mask

The bits set in the subnet mask decides the part of the IP address that contains the address of the subnet/network.

In general:

- The network address is obtained by an AND operation on the IP address and subnet mask.
- The node address is obtained by an AND NOT operation on the IP address and subnet mask.

Subnetwork

All the devices interconnected by switches are nodes of the same network or subnet. All the devices in a subnet can communicate directly with each other.

All devices in the same subnet have the same subnet mask.

A subnet is physically restricted by a router.

Substitute

→ *Proxy*

Substitute value

Substitute values are configurable values which output modules transfer to the process when the CPU switches to STOP mode.

In the event of an I/O access error, a substitute value can be written to the accumulator instead of the input value which could not be read (SFC 44).

Switch

In contrast to PROFIBUS DP, Industrial Ethernet is made up of point-to-point links: Each communication node is connected directly to one other communication node.

Multiple communication nodes are interconnected at the port of an active network component, that is, at the switch. Other communication nodes (including switches) can then be connected to the other ports of the switch. The connection between a communication node and the switch remains a point-to-point link.

The task of a switch is therefore to regenerate and distribute received signals. The switch "learns" the Ethernet address(es) of a connected PROFINET device or other switches and forwards only the signals intended for the connected PROFINET device or connected switch.

A switch has a certain number of ports. At each port, connect a maximum of one PROFINET device or a further switch.

Two switch models are available in PROFINET IO systems: as external switch with enclosure, or as component of an S7 CPU or S7 CP, or of a distributed I/O system ET 200, e.g., as in the S7 CPU 317-2 PN/DP.

In our SCALANCE X device family you will find switches with electrical and optical ports or with a combination of both variants. The SCALANCE X202-2IRT, for example, has 2 electrical ports and 2 optical ports and supports IRT communication.

With STEP 7, you can configure and perform diagnostics on and address switches from the SCALANCE X device family as PROFINET IO devices.

System diagnostics

System diagnostics refers to the detection, evaluation, and signaling of errors that occur within the PLC, for example programming errors or module failures. System errors can be indicated by LEDs or in **STEP 7**.

System function

A system function (SFC) is a function that is integrated in the operating system of the CPU and can be called in the STEP 7 user program, when necessary.

System function block

A system function block (SFB) is a function block integrated in the CPU operating system that can be called in the STEP 7 user program when required.

System memory

System memory is an integrated RAM memory in the CPU. System memory contains the address areas (e.g. timers, counters, bit memories) and data areas that are required internally by the operating system (for example, communication buffers).

System status list

The system status list contains data that describes the current status of a SIMATIC S7. You can always use this list to obtain an overview of the following points:

- Status of the SIMATIC S7 extension.
- The current CPU configuration and configurable signal modules.
- The current states and processes in the CPU and in configurable signal modules.

Terminating resistor

The terminating resistor is used to avoid reflections on data links.

Timer

→ *Timers*

Timers

Timers are part of CPU system memory. The content of timer cells is automatically updated by the operating system, asynchronously to the user program. **STEP 7** instructions are used to define the precise function of the timer cell (for example, on-delay) and to initiate their execution (for example, start).

TOD interrupt

→ *Interrupt, time-of-day*

Token

Allows access to the bus for a limited time.

Topology

Network structure. Commonly used structures:

- Linear bus topology
- Ring topology
- Star topology
- Tree topology

Topology configuration

All the interconnected ports of the PROFINET devices in STEP 7 projects and their relationships to each other.

Transmission rate

Data transfer rate (in bps)

Twisted-pair

Fast Ethernet via twisted-pair cables is based on the IEEE 802.3u standard (100 Base-TX). The transmission medium is a shielded 2x2 twisted-pair cable with an impedance of 100 Ω (AWG 22). The transmission characteristics of this cable must meet the requirements of category 5.

The maximum length of the connection between the terminal and the network component must not exceed 100 m. The connections are implemented according to the 100 Base-TX standard with the RJ-45 connector system.

UDT

User Defined Type: User-defined data type with any design.

Ungrounded

Having no direct electrical connection to ground

Update time

Within this interval new data are supplied to an IO device / IO controller in the PROFINET IO system by the IO controller / IO device. The send cycle can be configured separately for each IO device and determines the interval at which data are sent from the IO controller to the IO device (outputs) as well as data from the IO device to the IO controller (inputs).

User program

In SIMATIC, we distinguish between the operating systems of the CPU and user programs. The user program contains all instructions, declarations and data for signal processing through which a system or process can be controlled. It is assigned to a programmable module (for example CPU, FM) and can be structured in smaller units (blocks).

Varistor

Voltage-dependent resistor

WAN

A network beyond LAN boundaries which allows, for example, intercontinental communication. Legal rights do not belong to the user but to the provider of the communication network.

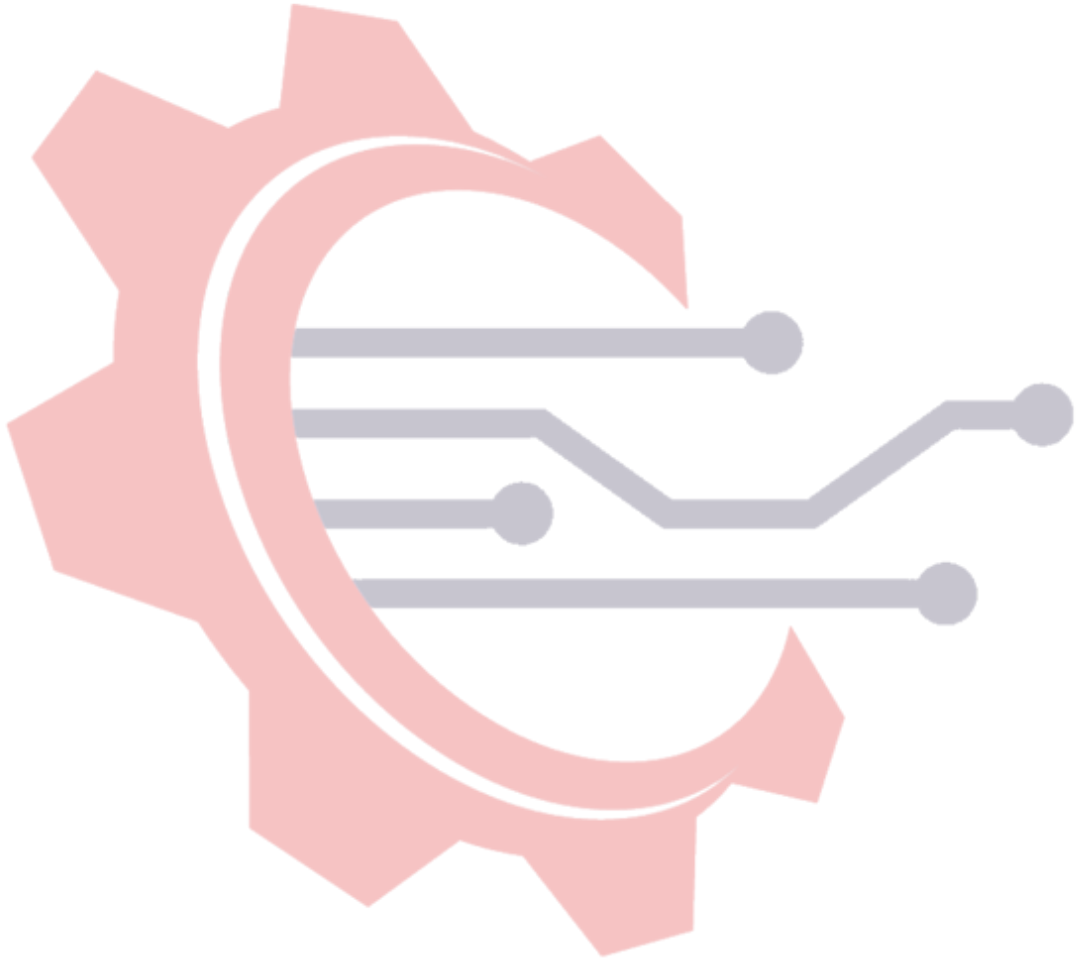

ماکان کنترول

Index

A

- Ambient condition
 - Climatic, 210
 - Mechanical, 209
 - Operating conditions, 209
- Analog I/O devices
 - Hardware low-pass filter, 280
 - Input filter, 281
- Analog inputs, 294
 - Not connected, 283
 - Parameterization, 286
 - Technical specifications, 295
- Analog outputs, 297
 - Not connected, 283
 - Parameterization, 287
 - Technical specifications, 297
- Approvals, 201
 - CE, 202
 - CSA, 202
 - FM, 203
 - IEC 61131, 204
 - Marine, 204
 - UL, 202
 - Use in industrial environments, 204
 - Use in residential areas, 205

B

- Backing up project data, 169
- Block
 - Delete, 163
 - Encrypting, 161
 - Overwriting, 162
 - PROFIBUS, 140
 - PROFINET, 140
 - Reloading, 162
 - Runtime modification by encryption, 162
 - Upload, 163

C

- Calculation
 - Cycle time, calculation method, 192

- Response time, calculation method, 192
- CE approval, 202
- Clock synchronization, 77
 - MPI interface, 77
 - PROFINET interface, 78
- Communication
 - Communication protocols, 81
 - CPU services, 65
 - Data consistency, 79
 - Data record routing, 76
 - Global data communication, 70
 - OP communication, 68
 - Open IE communication, 81
 - PG communication, 67
 - Point-to-point connection, 79
 - Routing, 71
 - S7 basic communication, 68
 - S7 communication, 69
 - Web server, 115
- Communication load
 - configured, 180
 - Dependency of actual cycle time, 181
 - Influence on the actual cycle time, 181
- Component Based Automation, 135
- Compressing, 163
- Connection resources
 - Distribution, 87
 - Example, 90
- CPU 312, Technical specifications, 303
- CPU 312C
 - Integrated inputs/outputs, 273
 - Technical specifications, 215
- CPU 313C, Technical Specifications, 224
- CPU 313C-2 DP, Technical Specifications, 233
- CPU 313C-2 PtP, Technical Specifications, 233
- CPU 314, Technical specifications, 311
- CPU 314C-2 DP, Technical Specifications, 245
- CPU 314C-2 PtP, Technical Specifications, 245
- CPU 315-2 DP, Technical specifications, 319
- CPU 315-2 PN/DP, Technical specifications, 329
- CPU 317-2 DP
 - Mode selector, 49
 - Operator controls and indicators, 47
 - Technical specifications, 344
- CPU 317-2 PN/DP, Technical specifications, 355
- CPU 319-3 PN/DP
 - Operator controls and indicators, 52
 - Technical specifications, 370

- CPU 31x
 - Mode selector, 46
 - Operator controls and indicators, 45
 - Status and error indicators, 54
- CPU 31x-2 PN/DP
 - Mode selector, 51
 - Operator controls and indicators, 50
- CPU 31xC
 - Mode selector, 23, 26, 29, 32, 35, 39, 43
 - Operator controls and indicators, 30
- CSA approval, 202
- Cycle time, 192
 - Calculation, 174, 192
 - Extension, 174
 - Introduction, 172
 - Reacting to events, 178
 - Sample calculation, 193
 - Sequence of cyclic program processing, 173
- Cycle time extension
 - CBA (Component Based Automation), 183
 - Test and commissioning, 182
- Cyclic interrupt, 198

- D**
- Data consistency, 79
- Data record routing, 76
- DB
 - Instructions List, 151
 - Retentive behavior, 151
- Degree of protection IP 20, 211
- Delete, 163
- Diagnostics, 290
- Digital inputs, 290
 - Parameterization, 284
 - Technical specifications, 291
- Digital outputs, 292
 - Parameterization, 285
 - Technical specifications, 293
- Display elements, 41
 - CPU 317-2 DP, 47
 - CPU 319-3 PN/DP, 52
 - CPU 31x, 45
 - CPU 31x-2 PN/DP, 50
 - CPU 31xC, 30
- Download, user program, 160
- DPV1, 91

- E**
- Electromagnetic compatibility (EMC), 206
 - Electrostatic discharge, 206
 - EMC (Electromagnetic compatibility), 206
 - Disturbance variables, 206
 - Radio interference, 207
- Encryption, 161
- Error display
 - CPU 31x, 54
- Example
 - Cycle time, 193
 - Interrupt response time, 199
 - Response time, 194
 - Routing, 74

- F**
- FM approval, 203

- G**
- Gateway, 71
- Global data communication, 70

- H**
- Hardware interrupt processing, 197

- I**
- I/O, integrated, 272
 - Analog I/O devices, 278
 - Analog inputs, 294
 - Analog outputs, 297
 - Diagnostics, 290
 - Digital inputs, 290
 - Digital outputs, 292
 - Interrupt inputs, 289
 - Parameterization, 283
- I-Device, 146
- IEC 61131, 204
- Industrial Ethernet, 81, 135
- Insulation test, 211
- Integrated inputs and outputs, 272
 - Technological functions and standard I/Os, 277
 - Usage, 272
- Interface
 - MPI, 57
 - PROFIBUS DP, 58
 - PROFINET, 59
 - PtP, 64
- Interrupt inputs, 289

- OB 40, 289
 - Parameterization, 284
 - Interrupt response time, 199
 - Calculation, 196
 - CPUs, 197
 - Hardware interrupt processing, 197
 - Sample calculation, 199
 - Signal modules, 197
 - Interrupt, reproducibility, 198
 - Interruption of communication for CPUs with integrated switch
 - CPU memory resets, firmware updates and power-offs, 62
 - IRT (Isochronous Real-Time)
 - Odd send clock, 62
 - Options, 143
 - Isochronous mode, 146
 - Isochronous Real-Time, 62
- L**
- Load memory
 - MMC, 149
 - Local data, 157
- M**
- Main memory, 150
 - Marine approval, 204
 - Measured value archive, 167
 - Media redundancy, 148
 - Media redundancy protocol, 148
 - Memory
 - Backing up project data, 169
 - Compressing, 163
 - Load memory, 149
 - Main memory, 150
 - Measured value archive, 167
 - Recipe, 165
 - Retentive behavior, 151
 - Retentive data, 150
 - System memory, 149
 - Memory functions, 159
 - Memory reset, 164
 - RAM to ROM, 163
 - Restart, 164
 - Upload, 163
 - Warm restart, 164
 - Memory reset, 164
 - Micro Memory Card, 158
 - MMC, 149
 - Mode selector
 - CPU 317-2 DP, 49
 - CPU 319-3 PN/DP, 54
 - CPU 31x, 46
 - CPU 31x-2 PN/DP, 51
 - CPU 31xC, 23, 26, 29, 32, 35, 39, 43
 - MPI (multi-point interface)
 - Interface, 57
 - MPI interface
 - Clock synchronization, 77
 - Connectable devices, 57
 - MRP (Media Redundancy Protocol), 148
- O**
- OBs
 - PROFIBUS, 142
 - PROFINET, 142
 - OP communication
 - Prioritized OCM communication, 68
 - Properties, 68
 - open IE communication), 82
 - Data blocks, 82
 - Disconnecting, 83
 - Establishing a connection, 83
 - Operating elements, 41
 - CPU 317-2 DP, 47
 - CPU 319-3 PN/DP, 52
 - CPU 31x, 45
 - CPU 31x-2 PN/DP, 50
 - CPU 31xC, 30
 - Overview
 - PROFINET IO functions, 138
- P**
- Parameterization
 - Interrupt inputs, 284
 - Standard AI, 286
 - Standard AO, 287
 - Standard DI, 284
 - Standard DO, 285
 - PG communication, 67
 - Point-to-point connection, 79
 - Port, 64
 - Prioritized startup, 144
 - Process input/output image, 154
 - PROFIBUS, 140
 - SFBs, 140
 - SFCs, 140
 - PROFIBUS DP interface, 58

Connectable devices, 59
 Operating modes with two DP interfaces, 58
 PROFIBUS International, 136
 PROFINET
 Compatibility with CPUs < V3.1, 60
 Device replacement without removable medium, 145
 Intelligent IO device, 146
 Interface, 59
 Introduction, 135
 IO devices changing at runtime, 145
 IRT, 143
 Isochronous mode, 146
 Media redundancy, 148
 Prioritized startup, 144
 SFBs, 140
 SFCs, 140
 Shared Device, 147
 PROFINET CBA, 135
 Cycle time extension, 183
 Distinguishing features compared to IO, 137
 PROFINET interface
 Addressing the ports, 61
 Clock synchronization, 78
 Configuring port properties, 63
 Connectable devices, 60
 Deactivating port, 64
 Port addressing, 64
 Send clock, 61
 Update time, 61
 PROFINET IO, 138
 Distinguishing features compared to CBA, 137
 Overview of functions, 138
 Promming, 163
 Protection class, 211
 PtP interface, 64

R

Radio interference, 207
 RAM to ROM, 163
 Recipe, 165
 Recycling, 7
 Response time
 Calculation, 192
 DP cycle times, 188
 Introduction, 187
 Longest, calculation, 191
 Longest, conditions, 190
 Reduction with direct I/O access, 191
 Sample calculation, 194
 Shortest, calculation, 189

Shortest, conditions, 189
 Update times for PROFINET IO, 188
 Restart, 164
 Retentivity
 Behavior of the memory objects, 151
 DB, 151
 Memory, 150
 Ring topology, 148
 Routing
 Connection resources, 89
 Example TeleService, 74
 Gateway, 71
 General, 71
 Number of connections, 72
 Requirements, 73

S

S7 basic communication, 68
 S7 communication, 69
 S7 connections
 CPUs 31xC, 88
 Distribution, 87
 End point, 84
 Pin assignments, 85
 Time sequence for allocation, 86
 Transition point, 84
 Scan cycle monitoring time, 179
 Scope of the manual, 3
 Scope of this documentation, 13
 Send clock
 Odd for IRT, 62
 PROFINET, 61
 SFBs
 PROFIBUS, 140
 PROFINET, 140
 SFCs
 PROFIBUS, 140
 PROFINET, 140
 Shared Device, 147
 Shipping conditions, 208
 SIMATIC Micro Memory Card
 Compatible Micro Memory Cards, 214, 302
 Load user program, 160
 Project data, 169
 Properties, 158
 Slot, 54
 Useful life, 159
 Simple Network Management Protocol, 80
 SNMP, 80
 Standards, 201
 Status indication

CPU 31x, 54
 Storage conditions, 208
 System memory, 149
 Address areas, 153
 Local data, 157
 Process image, 154

T

Technical specifications
 Analog inputs, 295
 Analog outputs, 297
 CPU 312, 303
 CPU 312C, 215
 CPU 313C, 224
 CPU 313C-2 DP, 233
 CPU 313C-2 PtP, 233
 CPU 314, 311
 CPU 314C-2 DP, 245
 CPU 314C-2 PtP, 245
 CPU 315-2 DP, 319
 CPU 315-2 PN/DP, 329
 CPU 317-2 DP, 344
 CPU 317-2 PN/DP, 355
 CPU 319-3 PN/DP, 370
 Digital inputs, 291
 Digital outputs, 293
 Electromagnetic compatibility (EMC), 206
 Shipping and storage conditions, 208
 Standards and certifications, 201
 Test voltage, 211
 Time-delay interrupt, 198
 Topology, 120

U

UL approval, 202
 Update time
 CPU 31x PN/DP, 62
 PROFINET interface, 61
 Upload, 163
 User program
 Download, 160
 Measured value archive, 167
 Recipe, 165
 Upload, 163

W

Warm restart, 164
 Web access

Via HMI devices and PDA, 94
 Via PG/PC, 94
 Web server - general
 Compatible web browser, 93
 HW Config, settings, 97
 Language settings, 95
 Safety functions, 95
 Updating and saving, 100
 Web server - web pages
 Communication, 115
 Diagnostic buffer, 104
 Identification, 103
 Messages, 113
 Module information, 106
 Start page, 101
 Status of the variables, 127
 Topology, 120
 Topology - graphical view, 121
 Topology - status overview, 126
 Topology - tabular view, 124
 User pages, 131
 Variable table, 128

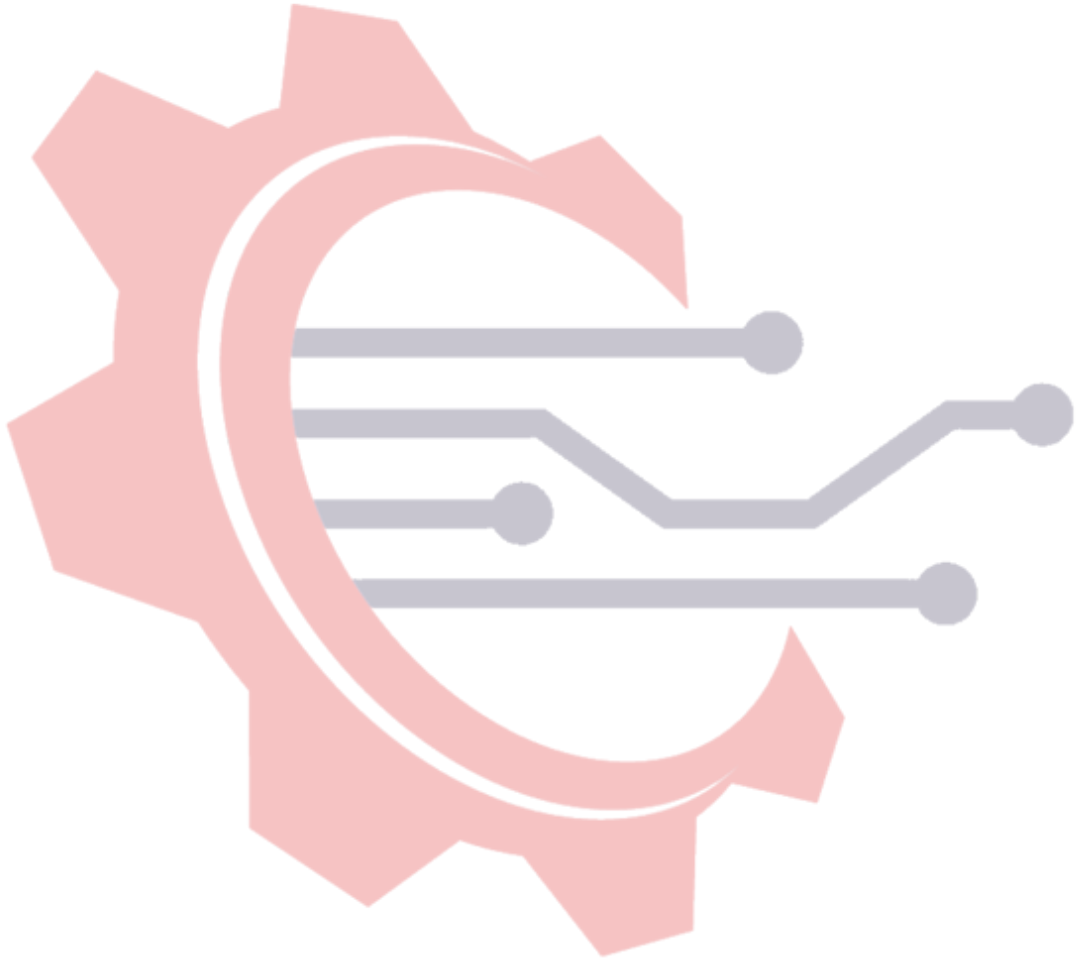

ماکان کنترول