

Product datasheet

Specifications



Altivar Soft Starter ATS130, 38A, 200 to 480V AC, control supply 24V DC

ATS130N2D38LT

Main

Range of product	Altivar Soft Starter ATS130
Product or component type	Soft starter
Product destination	Asynchronous motors
Product specific application	Simple machine
Device short name	ATS130
Network number of phases	3 phases
Utilisation category	AC-53A
Ue power supply voltage	200...480 V - 15...10 %
power supply frequency	50...60 Hz +/- 5 Hz
[Ie] rated operational current	38 A in line (at <40 °C)
Service factor at Ie	100
Torque control	False
IP degree of protection	IP20
Motor power kW	11 kW at 230 V normal duty 18.5 kW at 400 V normal duty 22 kW at 440 V normal duty
Motor power hp	10 hp at 200 V normal duty 10 hp at 208 V normal duty 10 hp at 230 V normal duty 25 hp at 460 V normal duty

Complementary

Overload current profile	300 % Ie for 5 s
On-load factor	70 %
Operating cycles/hour	50 cyc/h
Minimum motor current	20 % Ie
Device connection	In line
[Us] control circuit voltage	24 V DC +/- 10 %
Control power	21.6 W starting and stopping 3 W steady state
Integrated motor overload protection	False
Protection type	Phase failure: mains Thermal protection: starter Bypass error: starter Control voltage Us: starter
Rated current pwr loss specification	38.0 A

Power loss static current independent	3 W
Power loss per device current dependent	7 W
Power loss during starting	220 W 300 % I _e
Standards	EN/IEC 60947-4-2 UL 60947-4-2 IEC 60664-1
Product certifications	CE UKCA CCC RCM EAC UL
Marking	CE CCC UKCA RCM EAC
[Uc] control circuit voltage	24 V DC
Discrete input number	3
Discrete input type	(DI) digital input, 10 kOhm (DI2) digital input, 10 kOhm (BOOST) digital input, 10 kOhm
Input compatibility	Discrete input level 1 PLC conforming to EN/IEC 61131-2
Discrete input logic	Digital input at State 0: 0... < 5 V and ≤ 0.2 mA at State 1: > 13 V, ≥ 0.5 mA
Relay output number	1
Relay output type	Relay outputs R1A, R1C NO
Minimum switching current	2.5 mA at 24 V DC for relay outputs
Maximum switching current	On resistive load for relay outputs : 1 A 250 V AC 400000 cycles On resistive load for relay outputs : 1 A 30 V DC 400000 cycles On inductive load for relay outputs : 1 A 250 V AC cos phi = 0.4 100000 cycles On inductive load for relay outputs : 1 A 30 V DC cos phi = 0.4 100000 cycles
Discrete output number	1
Discrete output type	Non programmable digital output DQ1 ≤ 30 V 200 mA
Display type	1 LED (green) for control power energized 1 LED (yellow and red) for motor operation phases, errors
Display screen available	False
Operating position	Vertical +/- 30 degree
Height	166 mm
Width	55 mm
Depth	165 mm
Product weight	1.3 kg
Suitable for mounting onto standard rails	True
Function available	Deceleration voltage ramp Boost
internal bypass	True
material declaration	True

Environment

Pollution degree	Level 2
-------------------------	---------

environmental class (during operation)	Without salt mist: 3C3 conforming to IEC 60721-3-3 3S3 conforming to IEC 60721-3-3
[Uimp] rated impulse withstand voltage	4 kV
[Ui] rated insulation voltage	480 V
Electromagnetic compatibility	Conducted and radiated emissions level B conforming to IEC 60947-4-2 Short voltage interruptions level 3 conforming to IEC 61000-4-11 Electrostatic discharge level 2 conforming to IEC 61000-4-2 Radiated radio-frequency electromagnetic field immunity test level 1 conforming to IEC 61000-4-3 Electrical fast transient/burst immunity test level 2 conforming to IEC 61000-4-4 Oscillatory waves immunity level 3 conforming to IEC 61000-4-12 Voltage/current impulse level 2 conforming to IEC 61000-4-5 Conducted disturbances, induced by radiofrequency fields level 1 conforming to IEC 61000-4-6
Ambient air temperature for operation	-10...40 °C (without derating) 40...60 °C (with current derating 1.5 % per °C)
Ambient air temperature for storage	-25...70 °C
Ambient air transport temperature	-40...70 °C
Operating altitude	0...1000 m without derating 1000...4000 m 1 % per 100 m
Relative humidity	5...95 % non condensing without dripping water conforming to IEC 60068-2-3
Maximum acceleration under vibrational stress (during operation)	10 m/s ² at 9...200 Hz
Maximum acceleration under vibratory load (during storage)	10 m/s ² at 9...200 Hz
Maximum acceleration under vibratory load (during transport)	10 m/s ² at 9...200 Hz
Maximum deflection under vibratory load (during operation)	3 mm at 2-9 Hz
Maximum deflection under vibratory load (during storage)	3 mm at 2-9 Hz
Maximum deflection under vibratory load (during transport)	3 mm at 2-9 Hz
Maximum acceleration under shock impact (during operation)	100 m/s ² at 11 ms
Maximum acceleration under shock load (during storage)	100 m/s ² at 11 ms
Maximum acceleration under shock load (during transport)	100 m/s ² at 11 ms

Packing Units

Unit Type of Package 1	PCE
Number of Units in Package 1	1
Package 1 Height	6.300 cm
Package 1 Width	27.000 cm
Package 1 Length	27.500 cm
Package 1 Weight	1.516 kg
Unit Type of Package 2	S06
Number of Units in Package 2	40
Package 2 Height	75.000 cm
Package 2 Width	60.000 cm
Package 2 Length	80.000 cm
Package 2 Weight	69.500 kg

Contractual warranty

Warranty (in months)

18



ماكان كنترول



Environmental Data

Schneider Electric aims to achieve Net Zero status by 2050 through supply chain partnerships, lower impact materials, and circularity via our ongoing “Use Better, Use Longer, Use Again” campaign to extend product lifetimes and recyclability.

[Environmental Data explained >](#)

[How we assess product sustainability >](#)



Environmental footprint

Total lifecycle Carbon footprint	180 kg CO2 eq.
Carbon footprint of the manufacturing phase [A1 to A3]	92 kg CO2 eq.
Carbon footprint of the distribution phase [A4]	0.2 kg CO2 eq.
Carbon footprint of the installation phase [A5]	0 kg CO2 eq.
Carbon footprint of the use phase [B2, B3, B4, B6]	88 kg CO2 eq.
Carbon footprint of the end-of-life phase [C1 to C4]	0.2 kg CO2 eq.
Environmental Disclosure	Product Environmental Profile

Use Better



Materials and Substances

Packaging made with recycled cardboard	Yes
Packaging without single use plastic	Yes
EU RoHS Directive	Compliant
REACH Regulation	Free of Substances of Very High Concern above the threshold

Use Longer



Lifetime extension

Repair	No
--------	----

Use Again



Repack and remanufacture

End of life manual availability	End of Life Information
Take-back	No
WEEE Label	 The product must be disposed on European Union markets following specific waste collection and never end up in rubbish bins

Dimensions Drawings

Dimensions

Soft Starter

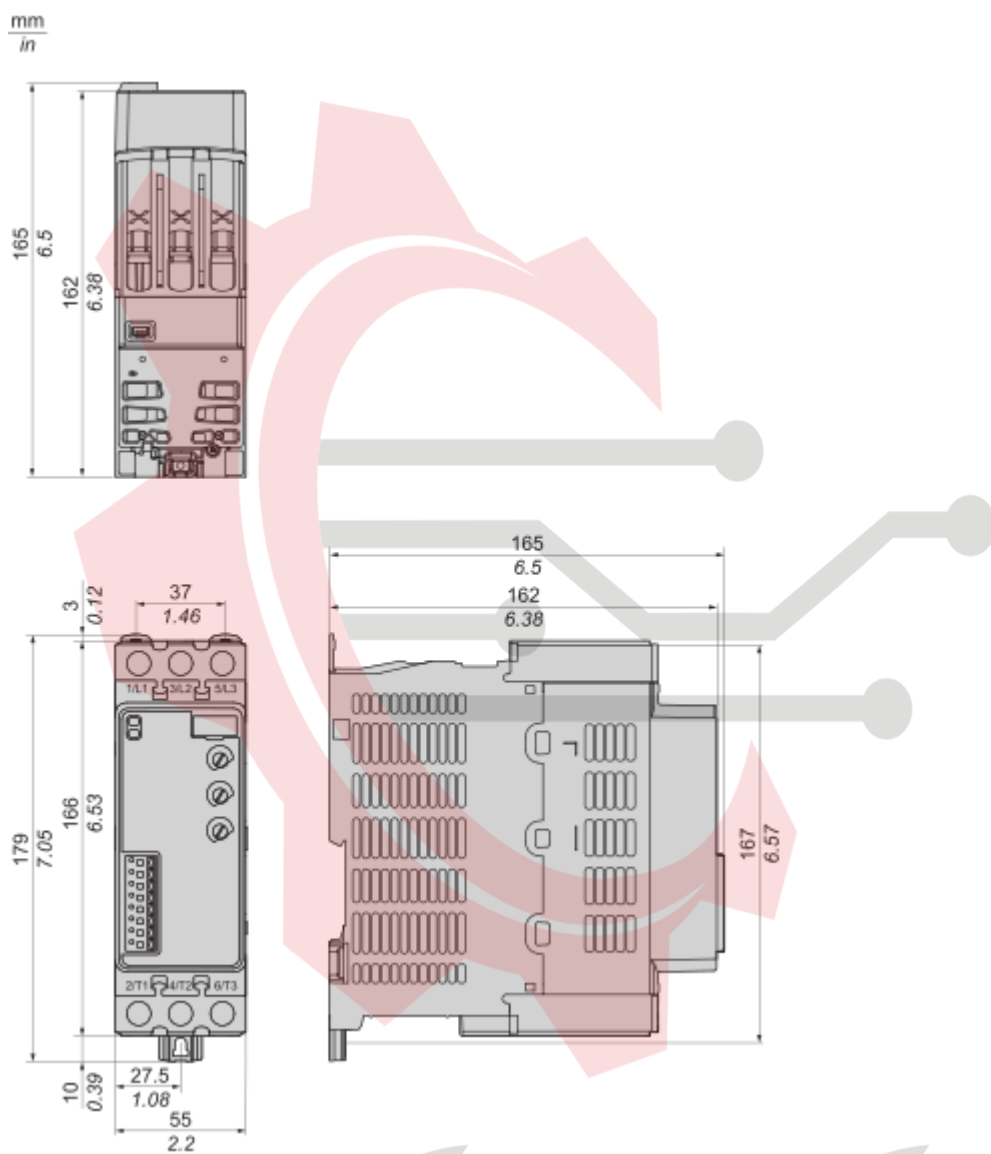

ماکان کنترول

Dimensions

Soft Motor Starter

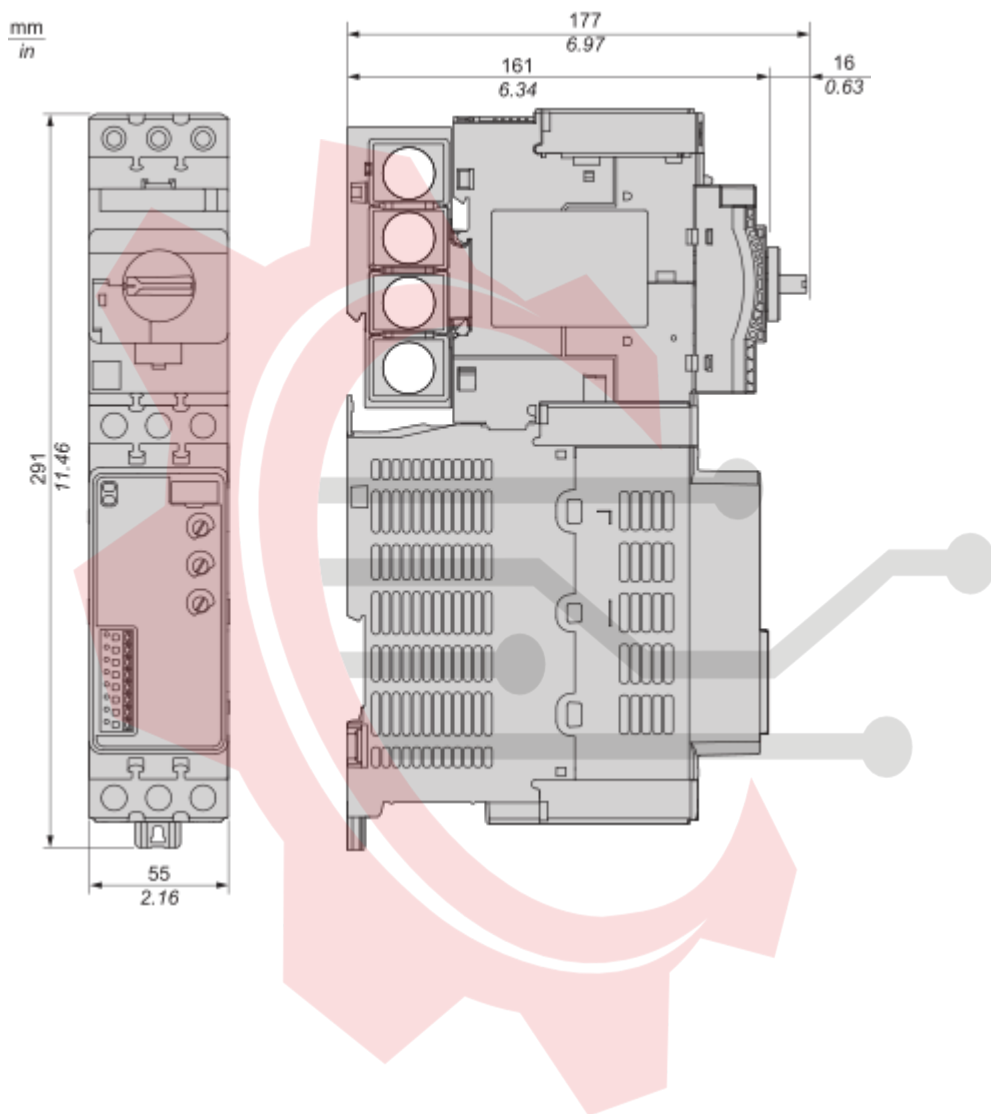

ماکان کنترول

Mounting and Clearance

Mounting

ATS130 Standalone

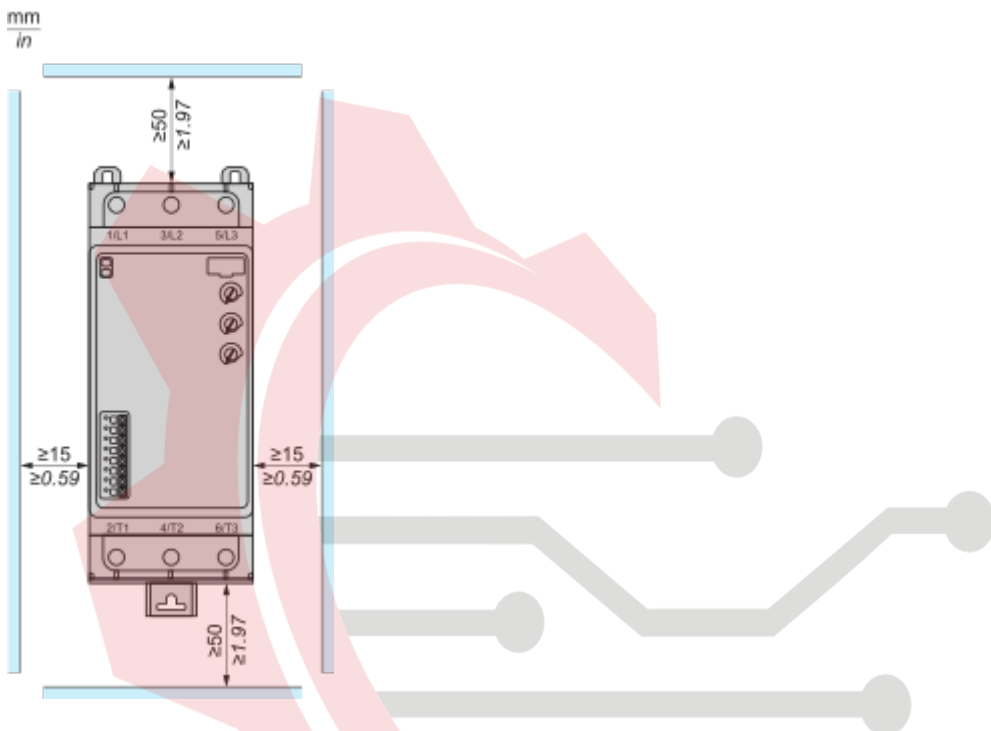

ATS130 Side by side

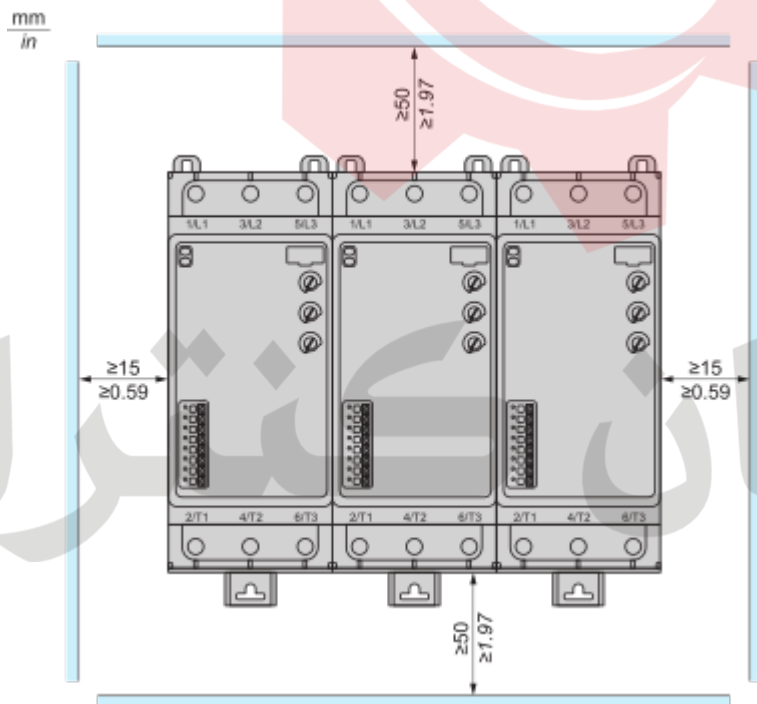

ATS130 Soft Motor Starter (ATS130 + TeSys Deca circuit breaker)

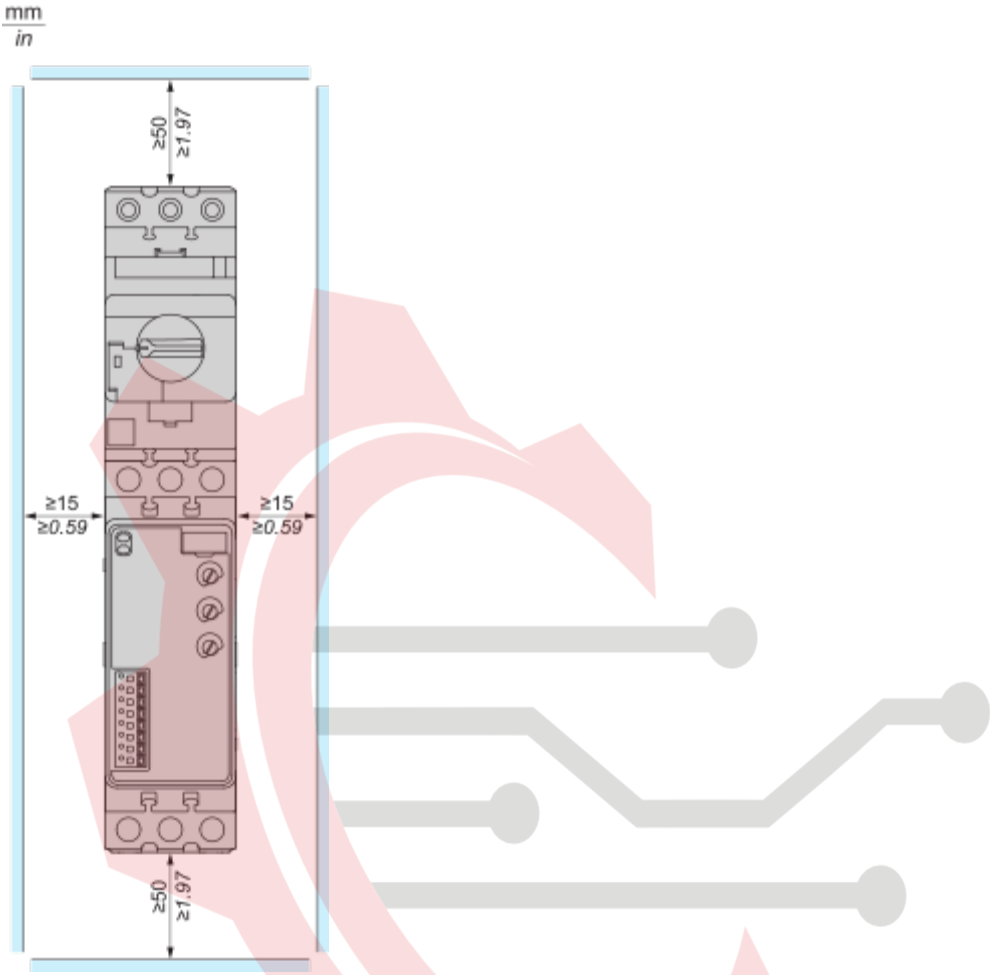

ماکان کنترول

Connections and Schema

Wiring

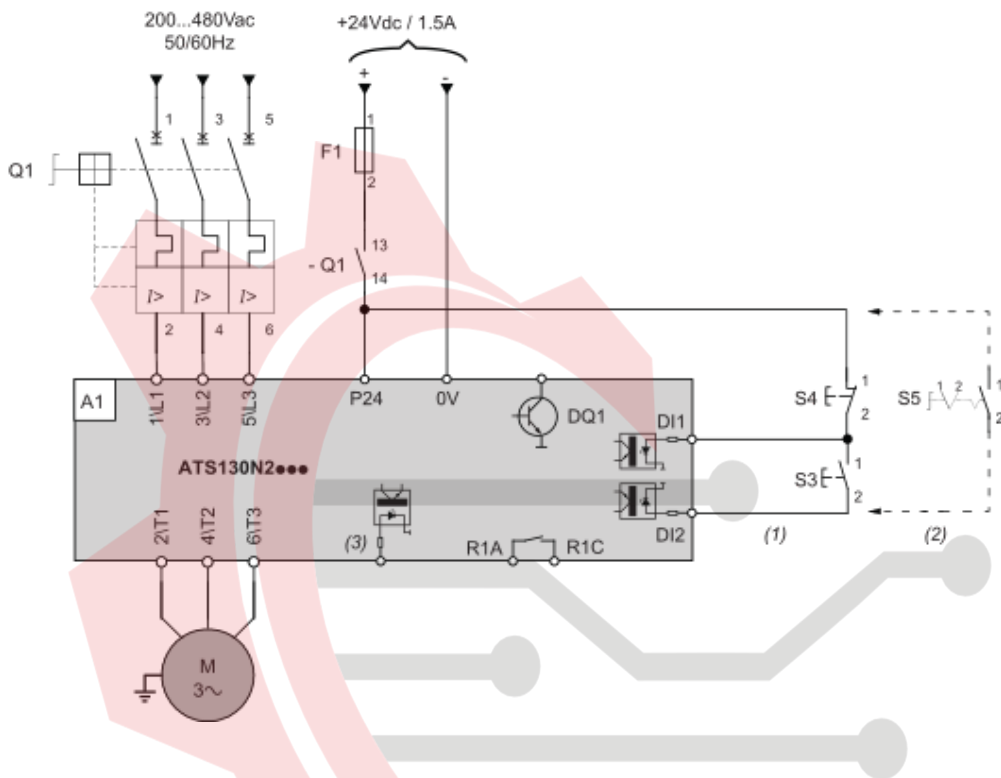

NOTE: Set the potentiometer  **Stop Time (s)** to 0 to get a freewheel.

- (1): 3-Wire control
- (2): 2-Wire control
- (3): BOOST

Designation Component

Q1	Circuit breaker
- Q1	Auxiliary contact of the circuit breaker Q1
F1	Fuse
S3	Normally open push-button
S4	Normally closed push-button
S5	Selector switch, 2 positions, normally open contact RUN/STOP command for 2-wire control

Description

Thermal-magnetic motor circuit breaker
Normally open auxiliary contact
Short circuit protection of the 24Vdc control supply
RUN order
STOP order and freewheel or controlled stop
Selector switch, 2 positions, normally open contact RUN/STOP command for 2-wire control

ماکان کنترول

Wiring

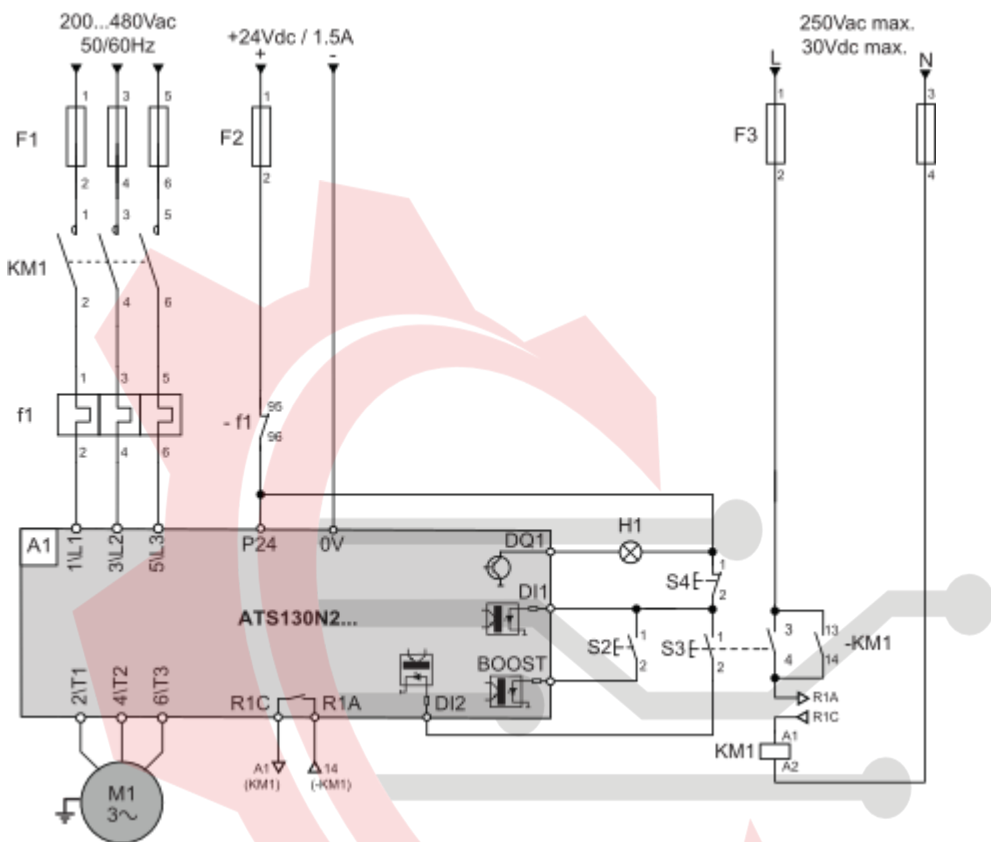

NOTE: Set the potentiometer  **Stop Time (s)** to 0 to get a freewheel.

Designation	Component	Description
F1	Fuses	Short circuit protection device for the mains
KM1	Contactors	Line contactor
-KM1	Auxiliary contact of the contactor	Auxiliary contact of the contactor on the command part
f1	Motor overload relay	Thermal protection device for the motor
- f1	Auxiliary contact of the motor overload relay	Auxiliary contact of the motor overload relay F1 inserted in the control circuit
F2	Fuse	Short circuit protection of the 24Vdc control supply
F3	Fuses	Short circuit protection of the control supply
S2	Normally open contact push-button.	RUN command for BOOST command
S3	Normally open contact push-button.	RUN command for 3-wire control
S4	Normally closed contact push-button	STOP command for 3-wire control

Designation	Component	Description
H1	Light	Presence of current



ماكان كنترول

Technical Illustration

Dimensions

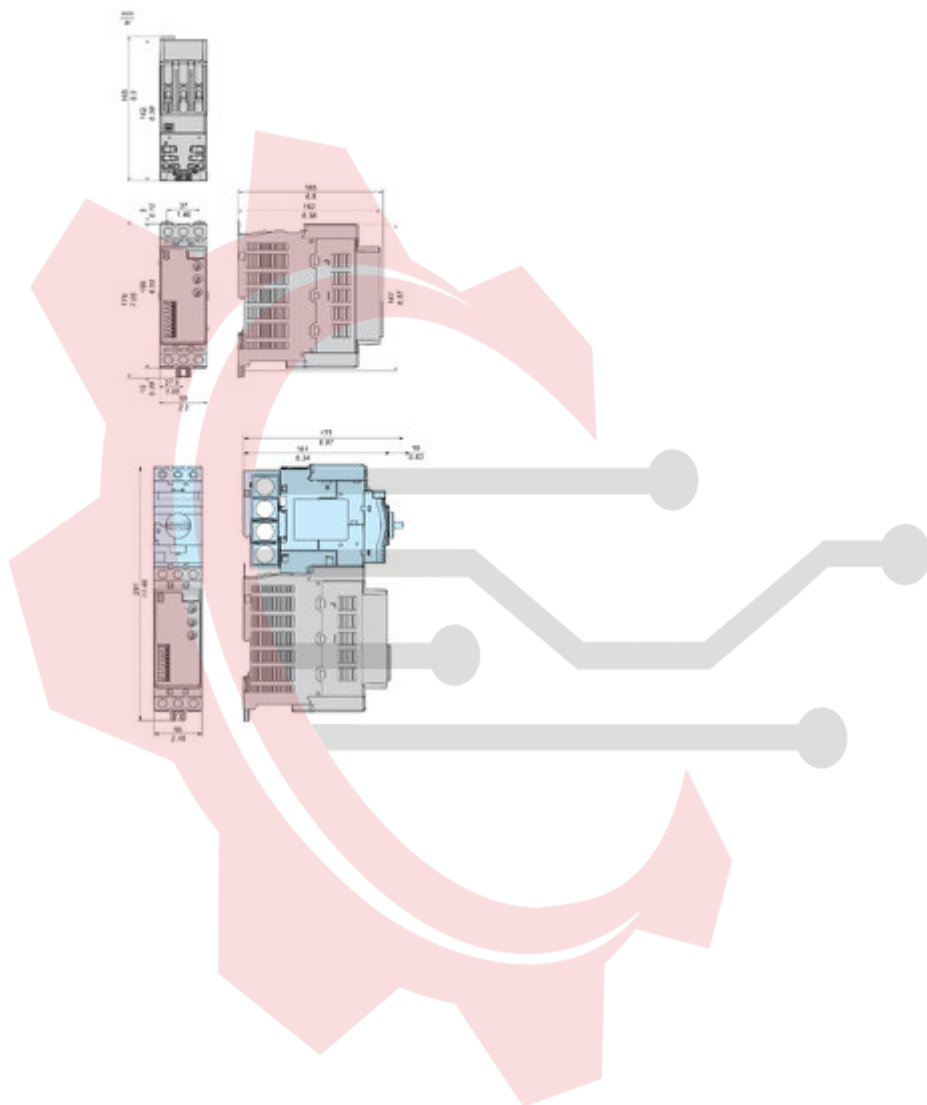

ماكان كنترول

Offer Marketing Illustration

Product benefits / Features

Features
Altivar Soft Starter ATS130

- Quick and easy installation
- Compact products and solutions
- Preventive maintenance free
- Easy product identification and support
- Extended operation cycle
- Flexibility

ماكان كنترول

Offer Marketing Illustration

Product benefits / Features

Technical Benefits

Altivar Soft Starter ATS130

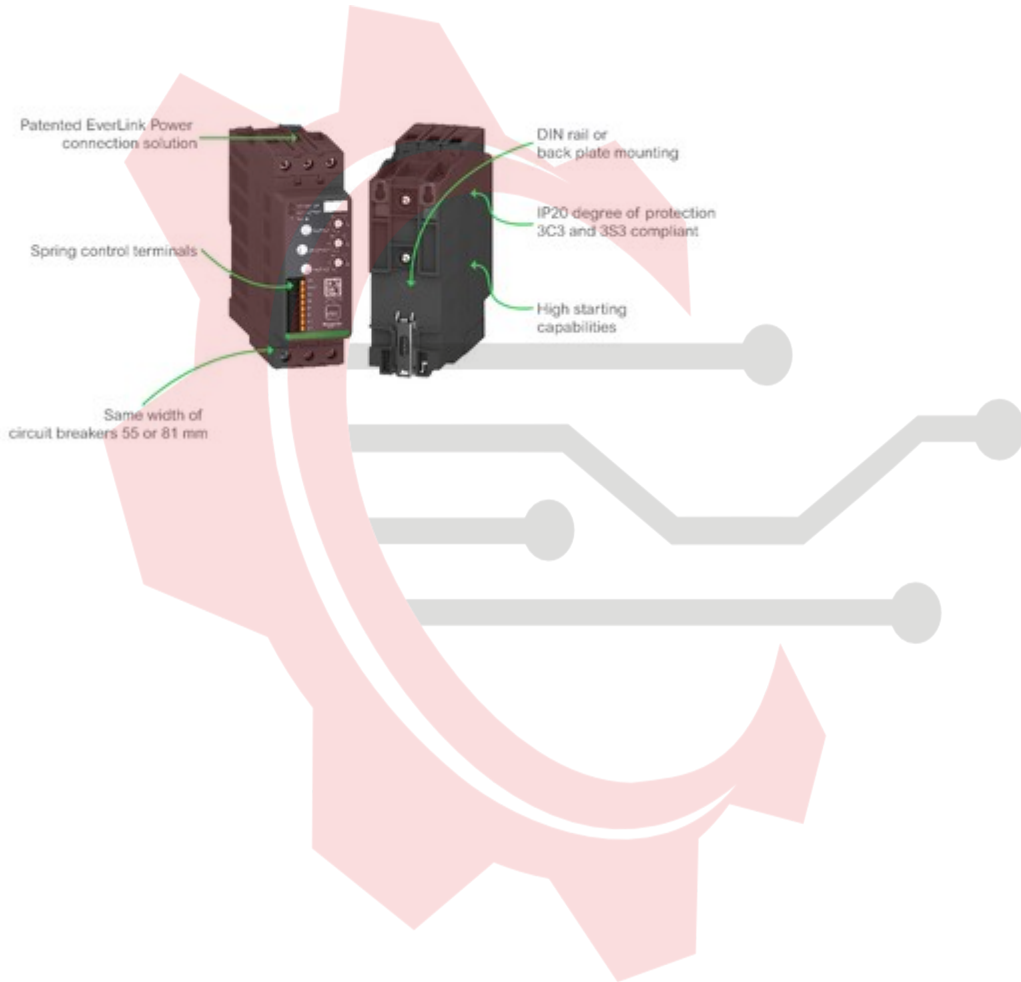

ماكان كنترول

Image of product / Alternate images

Alternative



ماكان داترول

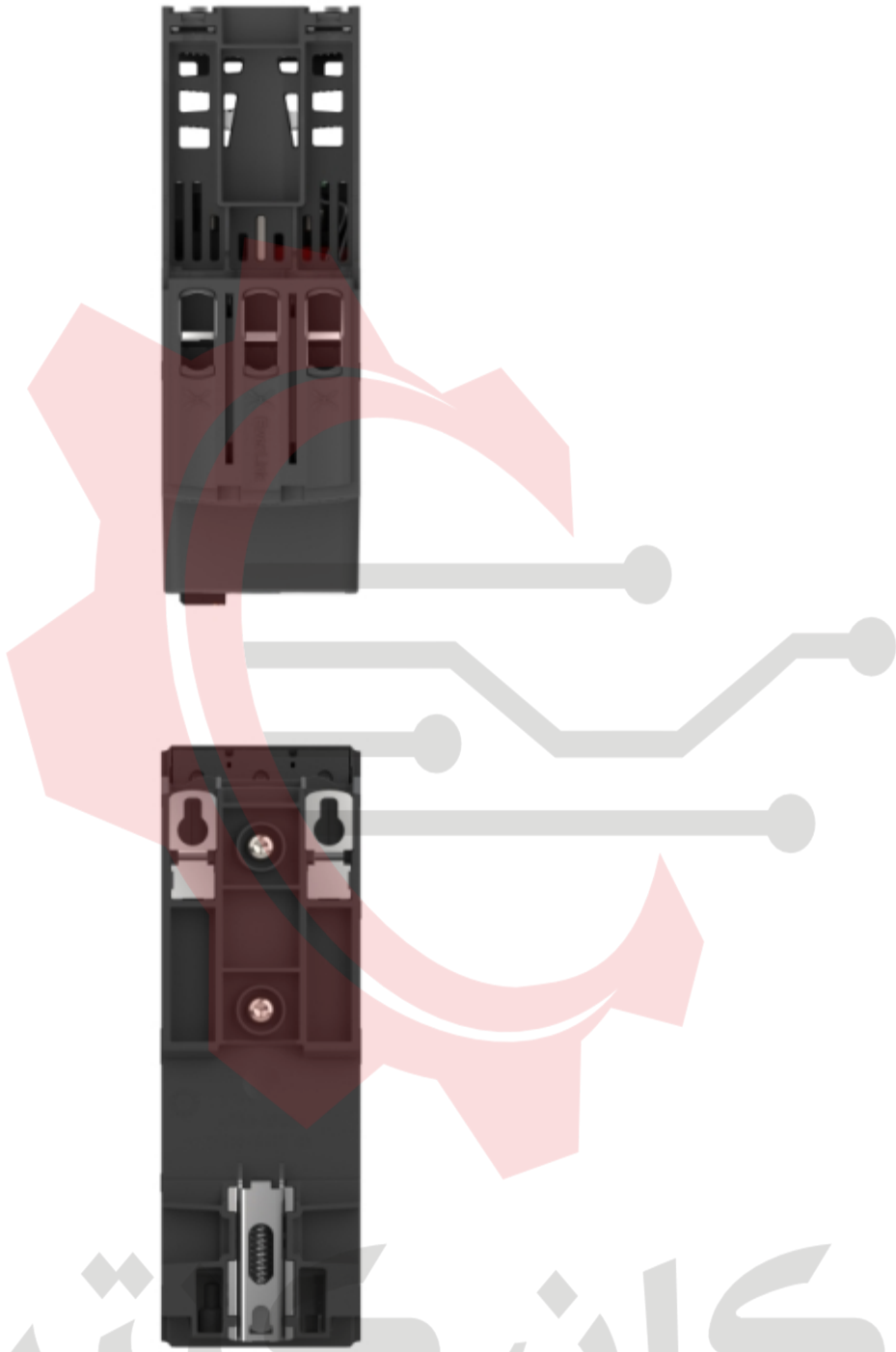

ماکان کنترول



ماکان کنترل